

B1000RW Series

Compact 1 x 2 Inch 10W Wide Input Range DC/DC Converters



Key Features:

- 10W Output Power
- UL Approved (File E245422)
- 2:1 Input Voltage Range
- 1,500 VDC Isolation
- Meets EN55022 Class "A"
- Compact 1 x 2 Inch Case
- Single & Dual Outputs
- Industry Standard Pin-Out



Electrical Specifications

Specifications typical @ +25°C, nominal input voltage & rated output current, unless otherwise noted. Specifications subject to change without notice.

Parameter	Conditions	Min.	Typ.	Max.	Units
Input Start Voltage	12 VDC Input	8.0	8.5	9.0	VDC
	24 VDC Input	15.0	17.0	18.0	
	48 VDC Input	30.0	33.0	36.0	
Input Filter	π (Pi) Filter (Complies with EN55022 Class "A")				
Reverse Polarity Input Current				2.0	A
Short Circuit Input Power			3,500	4,500	mW

Parameter	Conditions	Min.	Typ.	Max.	Units
Output Voltage Accuracy			±0.5	±1.0	%
Output Voltage Balance	Dual Output , Balanced Loads		±0.5	±1.0	%
Line Regulation	V _{in} = Min to Max		±0.1	±0.3	%
Load Regulation	I _{out} = 10% to 100%		±0.1	±0.5	%
Ripple & Noise (20 MHz) (Note 1)			50	75	mV P - P
Ripple & Noise (20 MHz)	Over Line, Load & Temp.			100	mV P - P
Ripple & Noise (20 MHz)				15	mV rms
Output Power Protection		120			%
Transient Recovery Time (Note 2)	25% Load Step Change		150	300	μSec
Transient Response Deviation			±2.0	±4.0	%
Temperature Coefficient			±0.01	±0.02	%/°C
Output Short Circuit	Continuous				

Parameter	Conditions	Min.	Typ.	Max.	Units
Isolation Voltage	60 Seconds	1,500			VDC
Isolation Test Voltage	Flash Tested For 1 Sec	1,650			VDC
Isolation Resistance	500 VDC	1,000			MΩ
Isolation Capacitance	100 kHz, 1V		120	160	pF
Switching Frequency		260	300	340	kHz

Parameter	Conditions	Min.	Typ.	Max.	Units
Operating Temperature Range	Ambient	-40	+25	+71	°C
Operating Temperature Range	Case	-40		+90	°C
Storage Temperature Range		-50		+125	°C
Cooling	Free Air Convection				
Humidity	RH, Non-condensing			95	%
RFI	Six-Side Shielded Metal Case				
Conducted EMI	EN55022 Class "A"				

Parameter	Conditions	Min.	Typ.	Max.	Units
Case Size		2.0 x 1.0 x 0.40 Inches (50.8 x 25.4 x 10.2 mm)			
Case Material		Metal with Non-Conductive Base (UL94-V0)			
Weight		1.06 Oz (30g)			

Parameter	Conditions	Min.	Typ.	Max.	Units
MTBF	MIL HDBK 217F, 25°C, Gnd Benign	700			kHours
Safety Standards		UL 1950, EN 60950, IEC 60950			
Safety Approvals		UL, cUL; File No. E245422			

Parameter	Conditions	Min.	Typ.	Max.	Units
Input Voltage Surge (1 Sec)	12 VDC Input	-0.7		25.0	VDC
	24 VDC Input	-0.7		50.0	
	48 VDC Input	-0.7		100.0	
Lead Temperature	1.5 mm From Case For 10 Sec			260.0	°C
Internal Power Dissipation	All Models			5,000	mW

Caution: Exceeding Absolute Maximum Ratings may damage the module. These are not continuous operating ratings.

MicroPower Direct

232 Tosca Drive
Stoughton, MA 02072
USA

T: (781) 344-8226

F: (781) 344-8481

E: sales@micropowerdirect.com

W: www.micropowerdirect.com



Model Selection Guide

Model Number	Input					Output			Efficiency (% Typ)	Fuse Rating Slow-Blow (mA)
	Voltage (VDC)		Current (mA)		Reflected Ripple Current (mA, Typ)	Voltage (VDC)	Current (mA, Max)	Current (mA, Min)		
	Nominal	Range	Full-Load	No-Load						
B1001RW	12	9.0 - 18.0	917	30	50	3.3	2,400.0	120.0	72	3,000
B1002RW	12	9.0 - 18.0	1,082	30	50	5.0	2,000.0	100.0	77	3,000
B1003RW	12	9.0 - 18.0	1,038	30	50	12.0	830.0	42.0	80	3,000
B1004RW	12	9.0 - 18.0	1,047	30	50	15.0	670.0	34.0	80	3,000
B1005RW	12	9.0 - 18.0	1,027	30	50	24.0	416.0	21.0	81	3,000
B1006RW	12	9.0 - 18.0	1,068	30	50	±5.0	±1,000.0	±50.0	78	3,000
B1007RW	12	9.0 - 18.0	1,027	30	50	±12.0	±416.0	±21.0	81	3,000
B1008RW	12	9.0 - 18.0	1,041	30	50	±15.0	±333.0	±17.0	80	3,000
B1011RW	24	18.0 - 36.0	434	20	25	3.3	2,400.0	120.0	76	1,500
B1012RW	24	18.0 - 36.0	534	20	25	5.0	2,000.0	100.0	78	1,500
B1013RW	24	18.0 - 36.0	506	20	25	12.0	830.0	42.0	82	1,500
B1014RW	24	18.0 - 36.0	511	20	25	15.0	670.0	34.0	82	1,500
B1015RW	24	18.0 - 36.0	501	20	25	24.0	416.0	21.0	83	1,500
B1016RW	24	18.0 - 36.0	521	20	25	±5.0	±1,000.0	±50.0	80	1,500
B1017RW	24	18.0 - 36.0	507	20	25	±12.0	±416.0	±21.0	82	1,500
B1018RW	24	18.0 - 36.0	507	20	25	±15.0	±333.0	±17.0	82	1,500
B1021RW	48	36.0 - 75.0	217	10	12	3.3	2,400.0	120.0	76	750
B1022RW	48	36.0 - 75.0	260	10	12	5.0	2,000.0	100.0	80	750
B1023RW	48	36.0 - 75.0	253	10	12	12.0	830.0	42.0	82	750
B1024RW	48	36.0 - 75.0	252	10	12	15.0	670.0	34.0	83	750
B1025RW	48	36.0 - 75.0	251	10	12	24.0	416.0	21.0	83	750
B1026RW	48	36.0 - 75.0	257	10	12	±5.0	±1,000.0	±50.0	81	750
B1027RW	48	36.0 - 75.0	251	10	12	±12.0	±416.0	±21.0	83	750
B1028RW	48	36.0 - 75.0	251	10	12	±15.0	±333.0	±17.0	83	750

Notes:

- When measuring output ripple, it is recommended that an external 0.47 μF ceramic capacitor be placed from the +Vout pin to the -Vout pin for single output units and from each output to common for dual output units.
- Transient recovery is measured to within a 1% error band for a load step change of 75% to 100%.
- Operation at no-load will not damage these units. However, they may not meet all specifications.
- Dual output units may be connected to provide a 10 VDC, 24 VDC or 30 VDC output. To do this, connect the load across the positive (+Vout) and negative (-Vout) outputs and float the output common.
- The converter should be connected to a low ac-impedance source. An input source with a highly inductive impedance may affect the stability of the converter. In applications where the converter output loading is high and input power is supplied over long lines, it may be necessary to use a capacitor on the input to insure start-up. In this case, it is recommended that a low ESR (ESR <1.0 Ω at 100 kHz) capacitor be mounted close to the converter. For 12V input units, a 15 μF is recommended; for 24V & 48V units a 4.7 μF .
- It is recommended that a fuse be used on the input of a power supply for protection. See the table above for the correct rating.

Derating Curve

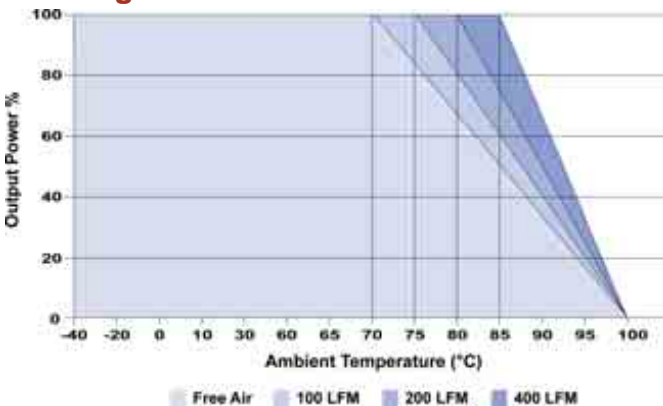

Mechanical Dimensions

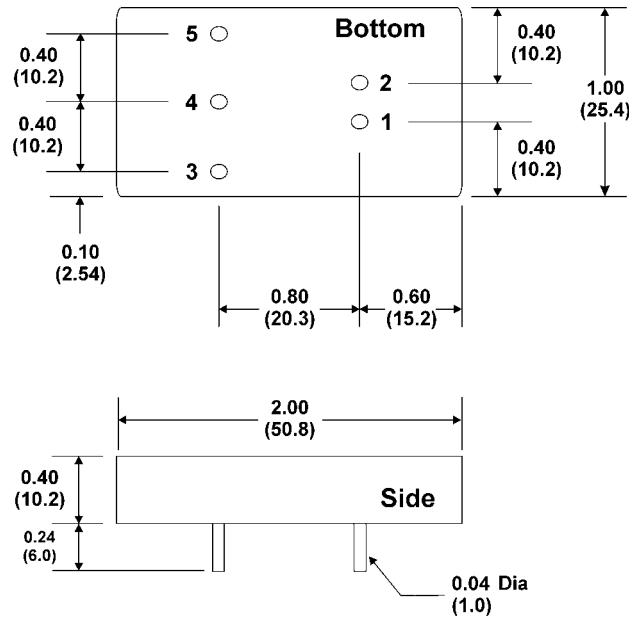

Capacitive Load

Single Output (μF Max)
470

Dual Output (μF Max)
±2,200

Pin Connections

Pin	Single	Dual
1	+Vin	+Vin
2	-Vin	-Vin
3	+Vout	+Vout
4	No Pin	Common
5	-Vout	-Vout

Mechanical Notes:

- All dimensions are typical in inches (mm)
- Tolerance x.xx = ± 0.01 (± 0.25)
- Leads are gold plated for improved solderability.



MicroPower Direct
www.micropowerdirect.com