



FLASH-ROM MODULE 16MByte (4M x 32-Bit), 72-Pin SIMM, 5V
Part No. HMF4M32M4GL

GENERAL DESCRIPTION

The HMF4M32M4GL is a high-speed flash read only memory (FROM) module containing 4,194,304 words organized in a x32bit configuration. The module consists of four 4M x 8bit FROM mounted on a 72 -pin, single-sided, FR4-printed circuit board.

Commands are written to the command register using standard microprocessor write timings.

Register contents serve as input to an internal state-machine, which controls the erase and programming circuitry. Write cycles also internally latch addresses and data needed for the programming and erase operations. Reading data out of the device is similar to reading from 12.0V flash or EPROM devices.

Four chip enable inputs, (/WE, /WE1, /WE2, /WE3) are used to enable the module's 8bits independently. Output enable (/OE) and write enable (/WE) can set the memory input and output.

When FROM module is disable condition the module is becoming power standby mode, system designer can get low -power design. All module components may be powered from a single +5V DC power supply and all inputs and outputs are TTL-compatible.

FEATURES

- w Access time : 75, 90 and 120ns
- w High-density 16MByte design
- w High-reliability, low-power design
- w Single + 5V \pm 0.5V power supply
- w Easy memory expansion
- w All inputs and outputs are TTL-compatible
- w FR4-PCB design
- w Low profile 72-pin SIMM
- w Minimum 1,000,000-write/erase cycle
- w Sectors erase architecture
- w Sector group protection
- w Temporary sector group unprotect ion
- w The used device is Am29F032B

PIN ASSIGNMENT

PIN	SYMBOL	PIN	SYMBOL	PIN	SYMBOL
1	Vss	25	DQ17	49	/BANK-E0
2	NC	26	DQ18	50	A18
3	DQ0	27	DQ19	51	A17
4	DQ1	28	DQ20	52	A16
5	DQ2	29	DQ21	53	A15
6	DQ3	30	Vcc	54	A14
7	DQ4	31	DQ22	55	A13
8	DQ5	32	DQ23	56	A12
9	DQ6	33	/WE2	57	A11
10	Vcc	34	NC	58	A10
11	DQ7	35	DQ24	59	Vcc
12	/WE0	36	DQ25	60	A9
13	/RY_BY	37	DQ26	61	A8
14	DQ8	38	DQ27	62	A7
15	DQ9	39	Vss	63	A6
16	DQ10	40	DQ28	64	A5
17	DQ11	41	DQ29	65	A4
18	DQ12	42	DQ30	66	A3
19	DQ13	43	DQ31	67	A2
20	DQ14	44	/WE3	68	A1
21	DQ15	45	NC	69	A0
22	/WE1	46	/RESET	70	A20
23	NC	47	A19	71	A21
24	DQ16	48	/OE	72	Vss

OPTION

MARKING

w Timing

75ns access	-75
90ns access	-90
120ns access	-120

w Packages

72-pin SIMM	M
-------------	---

72-PIN SIMM TOP VIEW

FUNCTIONAL BLOCK DIAGRAM

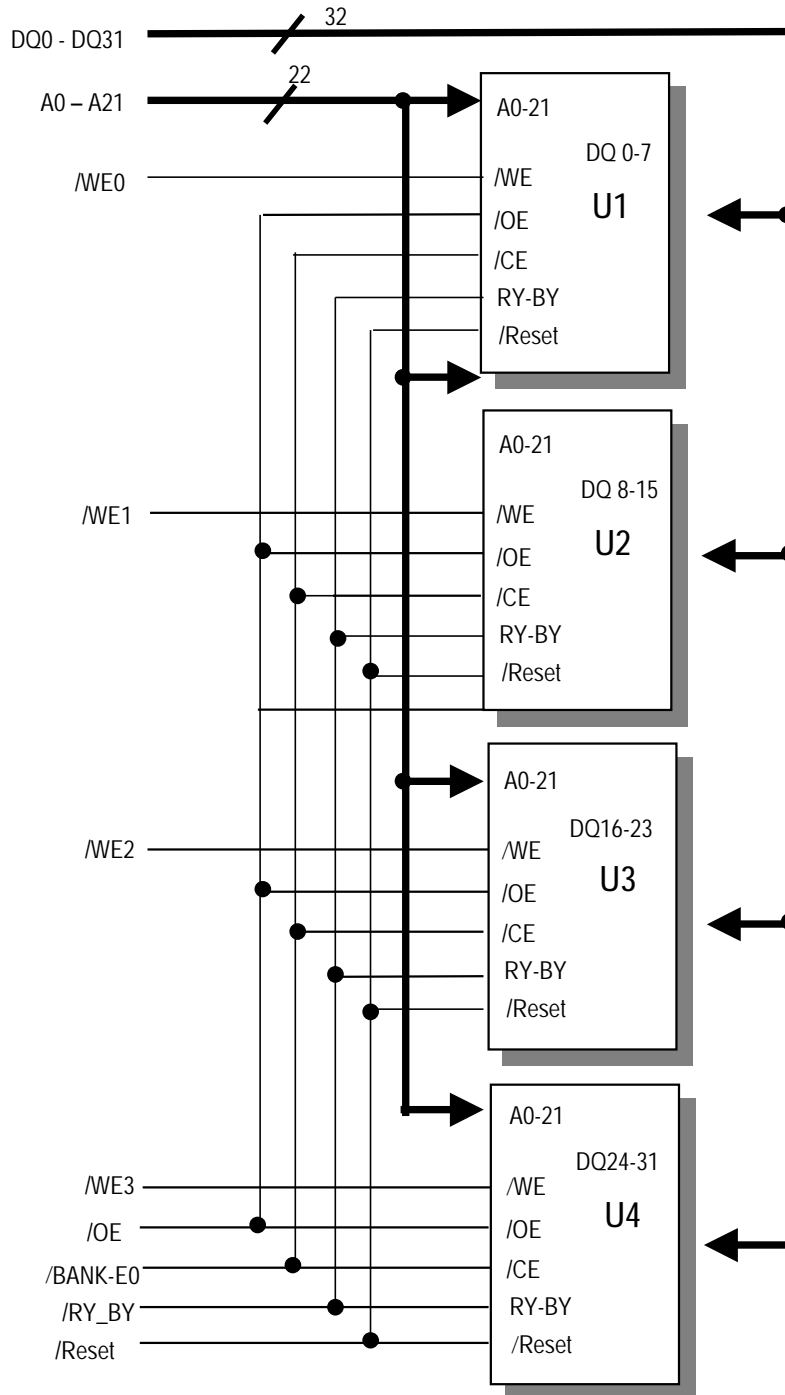

TRUTH TABLE

MODE	/OE	/CE	/WE	DQ	POWER
STANDBY	X	H	X	HIGH-Z	STANDBY
NOT SELECTED	H	L	H	HIGH-Z	ACTIVE
READ	L	L	H	Q	ACTIVE
WRITE or ERASE	X	L	L	D	ACTIVE

NOTE: X means don't care

ABSOLUTE MAXIMUM RATINGS

PARAMETER	SYMBOL	RATING
Voltage with respect to ground all other pins	$V_{IN,OUT}$	-2.0V to +7.0V
Voltage with respect to ground V_{CC}	V_{CC}	-2.0V to +7.0V
Storage Temperature	T_{STG}	-65°C to +150°C
Operating Temperature	T_A	-55°C to +125°C

w Stresses greater than those listed under "Absolute Maximum Ratings" may cause permanent damage to the device. This is a stress rating only and functional operation of the device at these or any other conditions above those indicated in the operating section of this specification is not implied. Exposure to absolute maximum rating conditions for extended periods may affect reliability.

RECOMMENDED DC OPERATING CONDITIONS

PARAMETER	SYMBOL	MIN	TYP.	MAX
V_{CC} for $\pm 5\%$ device supply voltage	V_{CC}	4.75V		5.25V
V_{CC} for $\pm 10\%$ device supply voltages	V_{CC}	4.5V		5.5V
Ground	V_{SS}	0	0	0

DC AND OPERATING CHARACTERISTICS ($0^{\circ}\text{C} \leq T_A \leq 70^{\circ}\text{C}$; $V_{CC} = 5\text{V} \pm 0.5\text{V}$)

PARAMETER	TEST CONDITIONS	SYMBOL	MIN	MAX	UNITS
Input Leakage Current	$V_{CC}=V_{CC\text{ max}}$, $V_{IN}= \text{GND to } V_{CC}$	I_{L1}		± 1.0	μA
Output Leakage Current	$V_{CC}=V_{CC\text{ max}}$, $V_{OUT}= \text{GND to } V_{CC}$	I_{L0}		± 1.0	μA
Output High Voltage	$I_{OH} = -2.5\text{mA}$, $V_{CC} = V_{CC\text{ min}}$	V_{OH}	2.4		V
Output Low Voltage	$I_{OL} = 12\text{mA}$, $V_{CC} = V_{CC\text{ min}}$	V_{OL}		0.45	V
V_{CC} Active Current for Read(1)	$/CE = V_{IL}$, $/OE = V_{IH}$	I_{CC1}		40	mA
V_{CC} Active Current for Program or Erase(2)	$/CE = V_{IL}$, $/OE = V_{IH}$	I_{CC2}		60	mA
V_{CC} Standby Current	$/CE = V_{IH}$	I_{CC3}		1.0	mA
Low V_{CC} Lock-Out Voltage		V_{LKO}	3.2	4.2	V

Notes:

1. The I_{CC} current listed is typically less than 2mA/MHz, with $/OE$ at V_{IH} .
2. I_{CC} active while embedded algorithm (program or erase) is in progress

3. Maximum I_{cc} current specifications are tested with V_{cc}=V_{cc} max

ERASE AND PROGRAMMING PERFORMANCE

PARAMETER	LIMITS			UNIT	COMMENTS
	MIN.	TYP.	MAX.		
Sector Erase Time	-	1	8	sec	Excludes 00H programming prior to erasure
Byte Programming Time	-	7	300	μs	Excludes system-level overhead
Chip Programming Time	-	28.8	86.4	sec	Excludes system-level overhead

TSOP CAPACITANCE

PARAMETER SYMBOL	PARAMETER DESCRIPTION	TEST SETUP	MIN	MAX	UNIT
C _{IN}	Input Capacitance	V _{IN} = 0	6	7.5	pF
C _{OUT}	Output Capacitance	V _{OUT} = 0	8.5	12	pF
C _{IN2}	Control Pin Capacitance	V _{IN} = 0	7.5	9	pF

Notes : Test conditions T_A = 25° C, f=1.0 MHz.

AC CHARACTERISTICS

u Read Only Operations Characteristics

PARAMETER SYMBOLS		DESCRIPTION	TEST SETUP	-75	-90	UNIT	
JEDEC	STANDARD						
t _{AVAV}	t _{RC}	Read Cycle Time	Min	70	90	ns	
t _{AVQV}	t _{ACC}	Address to Output Delay	/CE = V _{IL} /OE = V _{IL}	Max	70	90	ns
t _{ELQV}	t _{CE}	Chip Enable to Output Delay	/OE = V _{IL}	Max	70	90	ns
t _{GLQV}	t _{OE}	Chip Enable to Output Delay		Max	40	40	ns
t _{EHQZ}	t _{DF}	Chip Enable to Output High-Z		Max	20	20	ns
t _{GHQZ}	t _{DF}	Output Enable to Output High-Z		Max	20	20	ns
t _{AXQX}	t _{OH}	Output Hold Time From Addresses, /CE or /OE, Whichever Occurs First		Min	0	0	ns

TEST SPECIFICATIONS

TEST CONDITION	75	ALL OTHERS	UNIT
Output load	1TTL gate		
Output load capacitance, C _L (Including jig capacitance)	30	100	pF

Input rise and full times	5	20	ns
Input pulse levels	0.0 - 3.0	0.45-2.4	V
Input timing measurement reference levels	1.5	0.8	V
Output timing measurement reference levels	1.5	2.0	V

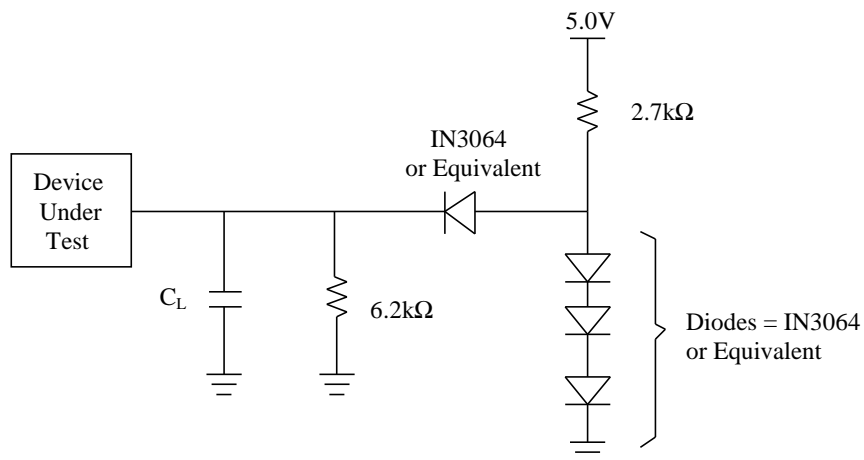

Note : $C_L = 100\text{pF}$ including jig capacitance

Write (Erase/Program) Operations

PARAMETER SYMBOLS		DESCRIPTION		-75	-90	UNIT
JEDEC	STANDARD					
t_{AVAV}	t_{WC}	Write Cycle Time	Min	70	90	ns
t_{AVWL}	t_{AS}	Address Setup Time	Min	0	0	ns
t_{WLAX}	t_{AH}	Address Hold Time	Min	40	45	ns
t_{DVWH}	t_{DS}	Data Setup Time	Min	40	45	ns
t_{WHDX}	t_{DH}	Data Hold Time	Min	0	0	ns
t_{GHWL}	t_{GHWL}	Read Recover Time Before Write	Min	0	0	ns
t_{ELWL}	t_{CS}	/CE Setup Time	Min	0	0	ns
t_{WHEH}	t_{CH}	/CE Hold Time	Min	0	0	ns
t_{WLWH}	t_{WP}	Write Pulse Width	Min	40	45	ns
t_{WHWL}	t_{WPH}	Write Pulse Width High	Min	20	20	ns
t_{WHWH1}	t_{WHWH1}	Byte Programming Operation	Typ	7	7	μs
t_{WHWH2}	t_{WHWH2}	Sector Erase Operation (Note1)	Typ	1	1	Sec
	t_{VCS}	Vcc set up time	Min	50	50	μs

Notes :

1. This does not include the preprogramming time

2. This timing is only for Sector Protect operations

Write(Erase/Program) Operations

Alternate /CE Controlled Writes

PARAMETER SYMBOLS		DESCRIPTION		-75	-90	UNIT
JEDEC	STANDARD					
t _{AVAV}	t _{WC}	Write Cycle Time	Min	70	90	Ns
t _{AVWL}	t _{AS}	Address Setup Time	Min	0	0	ns
t _{WLAX}	t _{AH}	Address Hold Time	Min	40	45	ns
t _{DVWH}	t _{DS}	Data Setup Time	Min	40	45	ns
t _{WHDX}	t _{DH}	Data Hold Time	Min	0	0	ns
	t _{OES}	Output Enable Setup Time	Min	0	0	ns
t _{GHWL}	t _{GHWL}	Read Recover Time Before Write	Min	0	0	ns
t _{ELWL}	t _{CS}	/CE Setup Time	Min	0	0	ns
t _{WHEH}	t _{CH}	/CE Hold Time	Min	0	0	ns
t _{WLWH}	t _{WP}	Write Pulse Width	Min	40	45	ns
t _{WHWL}	t _{WPH}	Write Pulse Width High	Min	20	20	ns
t _{WHWH1}	t _{WHWH1}	Byte Programming Operation	Typ	7	7	μs
t _{WHWH2}	t _{WHWH2}	Sector Erase Operation (Note1)	Typ	1	1	sec

Notes :

1. This does not include the preprogramming time
2. This timing is only for Sector Protect operations

u READ OPERATIONS TIMING

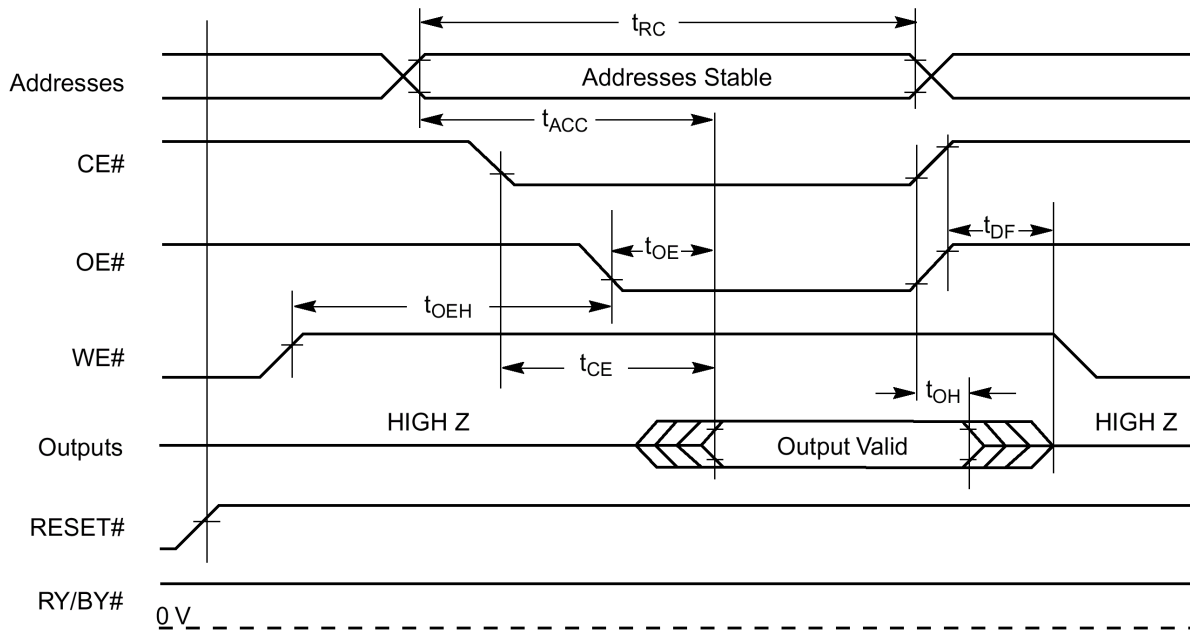

u RESET TIMING

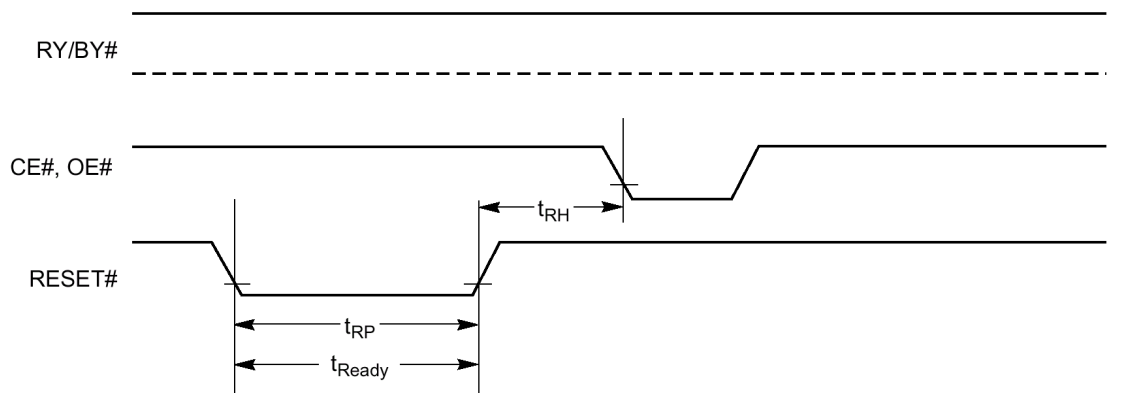

Reset Timings NOT during Embedded Algorithms

Reset Timings during Embedded Algorithms

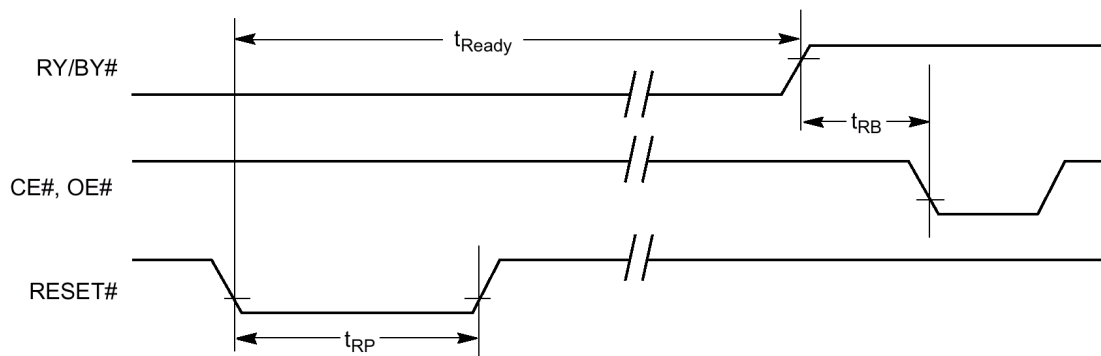

U PROGRAM OPERATIONS TIMING

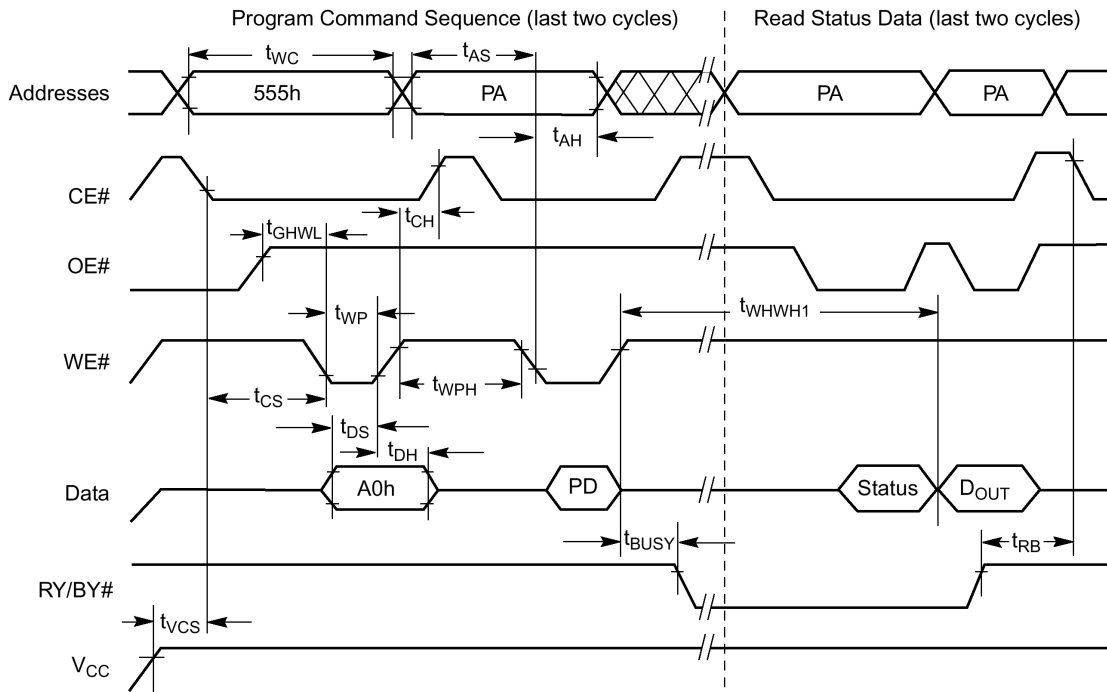

U CHIP/SECTOR ERASE OPERATION TIMINGS

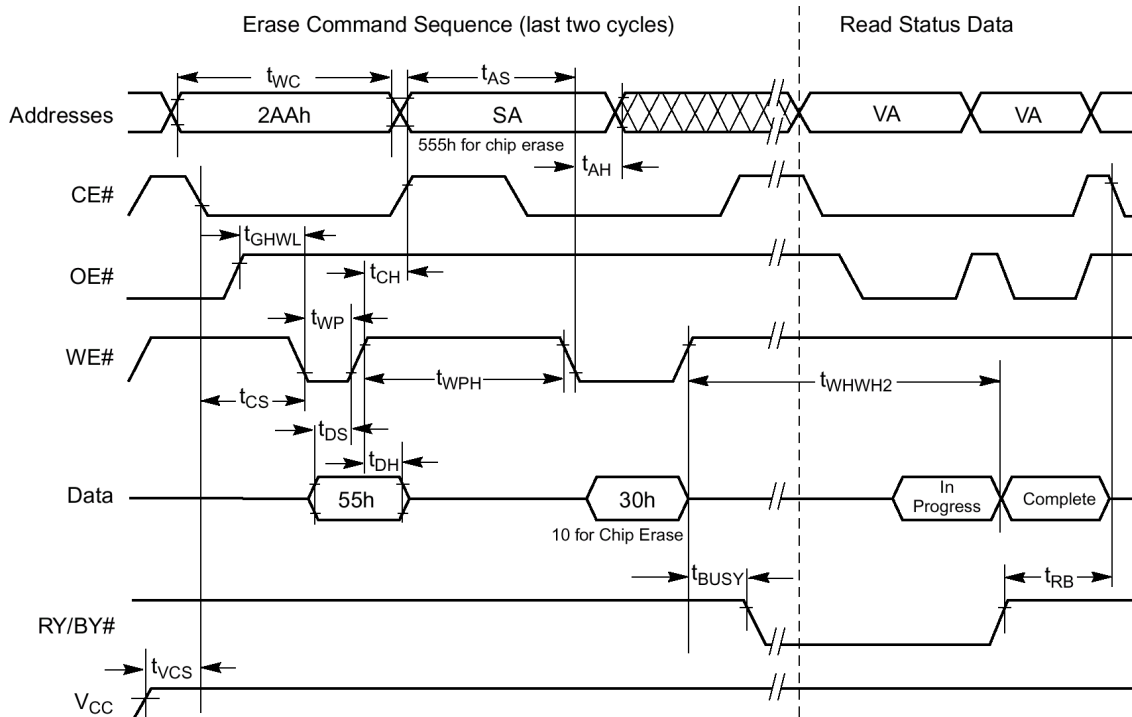

U DATA# POLLING TIMES(DURING EMBEDDED ALGORITHMS)

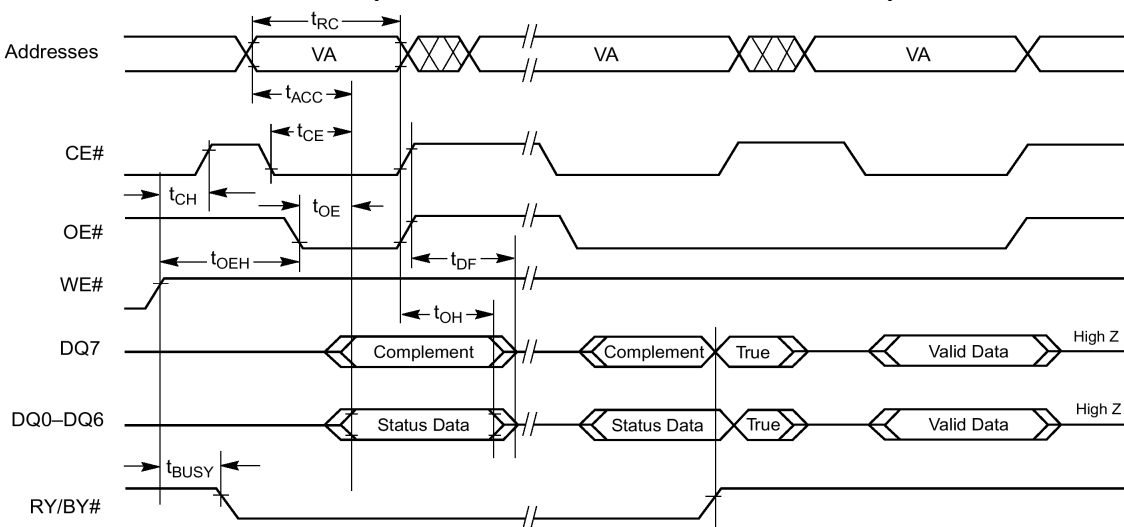

U TOGGLE# BIT TIMINGS (DURING EMBEDDED ALGORITHMS)

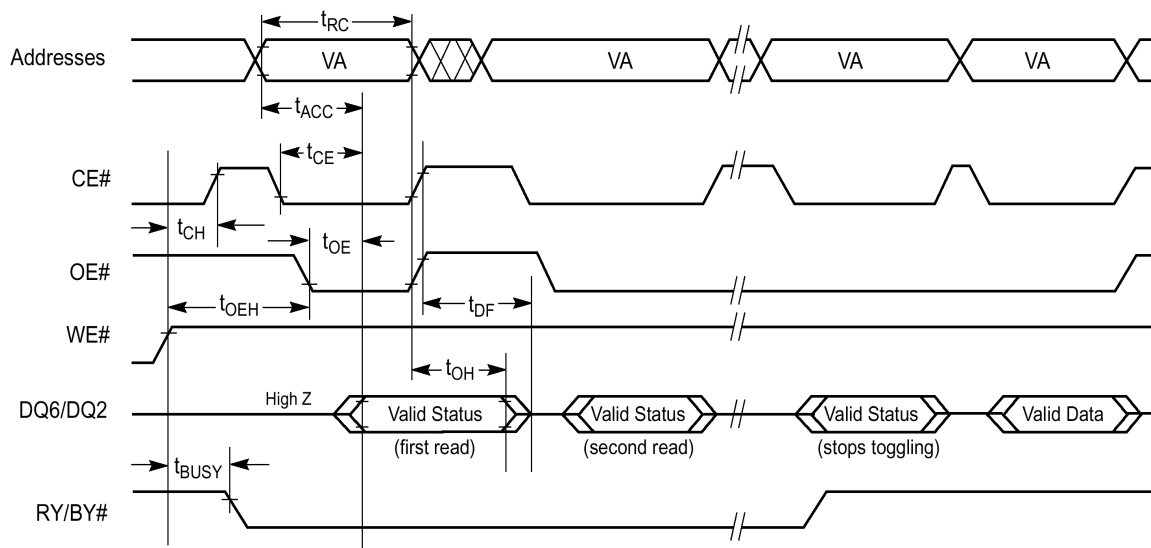

U SECTOR PROTECT UNPROTECT TIMEING DIAGRAM

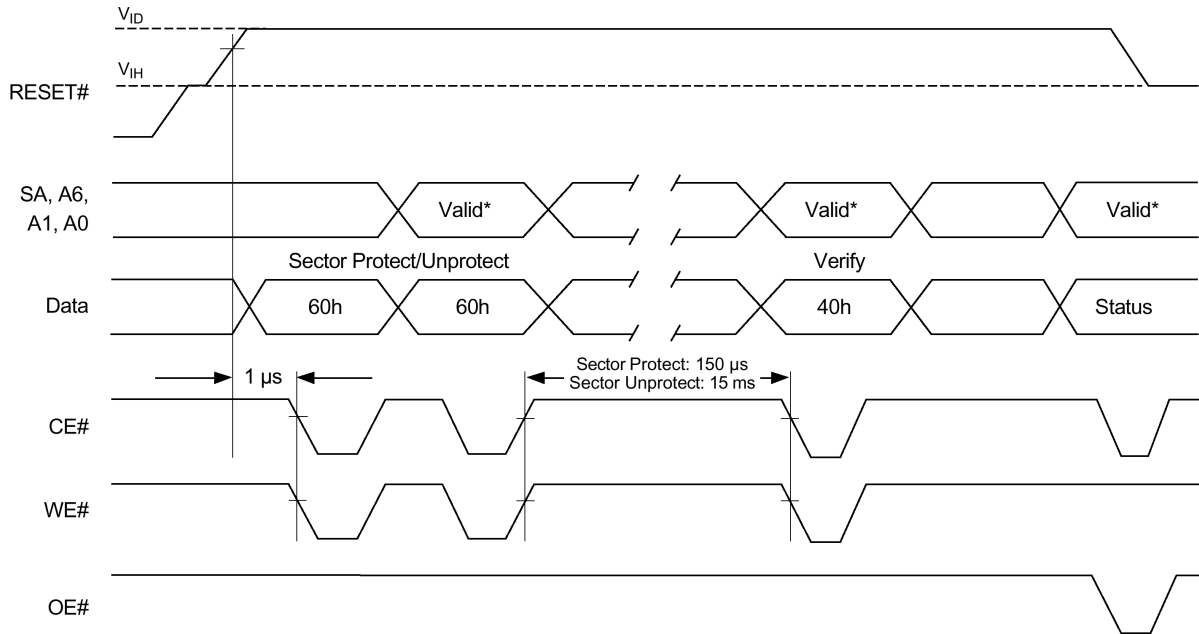

U ALTERNATE $CE\#$ CONTROLLED WRITE OPERATING TIMINGS

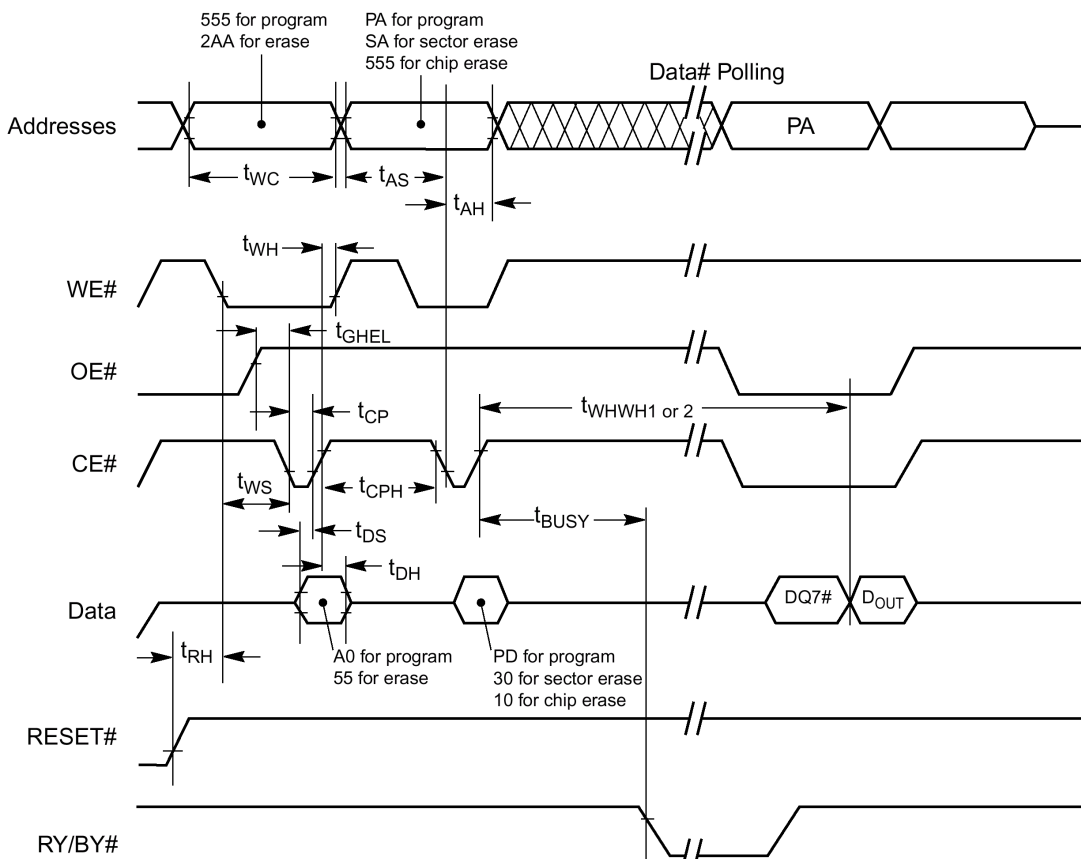

PACKAGE DIMENSIONS

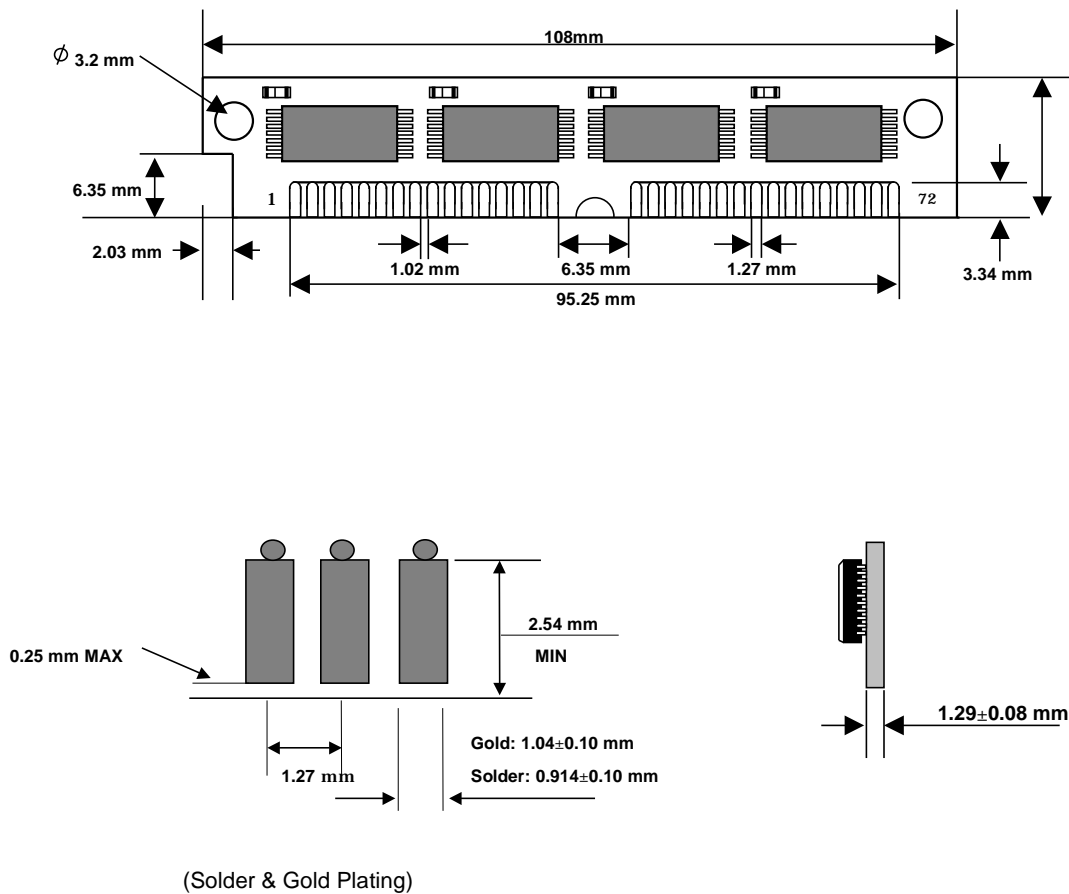

ORDERING INFORMATION

Part Number	Density	Org.	Package	Component Number	Vcc	SPEED
HMF4M32M4GL-75	16MByte	4MX 32bit	72 Pin-SIMM	4EA	5V	75ns
HMF4M32M4GL-90	16MByte	4MX 32bit	72 Pin-SIMM	4EA	5V	90ns
HMF4M32M4GL-120	16MByte	4MX 32bit	72 Pin-SIMM	4EA	5V	120ns