

# MPE-255 Series

## Single Output, 25W Compact, Enclosed AC/DC Power Supplies



### Key Features:

- 25W Output Power
- Universal 85-264 AC Input
- EN60950 Approved
- Four Single Output Models
- Meets EN55022
- >325 kHour MTBF
- Compact Metal Enclosure



RoHS Compliant



### MicroPower Direct

292 Page Street  
Suite D  
Stoughton, MA 02072  
USA

T: (781) 344-8226  
F: (781) 344-8481  
E: sales@micropowerdirect.com  
W: www.micropowerdirect.com



### Electrical Specifications

Specifications typical @ +25°C, nominal input voltage & rated output current, unless otherwise noted. Specifications subject to change without notice.

#### Input

Parameter	Conditions	Min.	Typ.	Max.	Units
Input Voltage Range	Universal	85		264	VAC
				370	VDC
Input Frequency		47		63	Hz
Input Current	See Model Selection Guide				
Inrush Current	Cold Start, 115 VAC		15.0		A Pk
	Cold Start, 230 VAC		30.0		
Safety Ground Leakage Current	115 VAC			0.45	mA
	230 VAC			0.75	

#### Output

Parameter	Conditions	Min.	Typ.	Max.	Units
Output Voltage	See Model Selection Guide				
Output Current	See Model Selection Guide				
Output Voltage Adjustment	See Model Selection Guide				
Output Voltage Tolerance, See Note 1	See Model Selection Guide				
Ripple & Noise (20 MHz), See Note 2	See Model Selection Guide				
Hold-Up Time	115 VAC		12		mSec
	230 VAC		80		
Set-Up Time	115 VAC		800		mSec
	230 VAC		300		
Rise Time	115 VAC		50		mSec
	230 VAC		50		
Temperature Coefficient			±0.02		%/°C
Short Circuit Protection	Continuous (Autorecovery)				
Over Voltage Protection	See Note 3	115		135	% Vout
Overload Protection	See Note 4	135		165	% Iout

#### General

Parameter	Conditions	Min.	Typ.	Max.	Units	
Isolation Voltage	Input to Output	3,000			VAC	
	Input to Ground	1,500				
	Output to Ground	500				
Isolation resistance	500 VDC		100		MΩ	
EMC Compliance	EMI/RFI	Conducted EN 55022; EN 61000-3-2, -3				
	Electrostatic Discharge (ESD)	IEC/EN 61000-4-2, -6, -8, -11				
		RF Field Susceptibility	IEC/EN 61000-4-3			
		Electrical Fast Transients/Bursts On Mains	IEC/EN 61000-4-4			
		Surge	IEC/EN 61000-4-5			
Switching Frequency			56		kHz	

#### Environmental

Parameter	Conditions	Min.	Typ.	Max.	Units
Operating Temperature Range	Ambient	-10	+25	+60	°C
Storage Temperature Range		-20		+85	°C
Cooling	Free Air Convection (See Derating Curve)				
Humidity	RH, Non-condensing	20		90	%

#### Physical

Case Size	3.90 x 3.82 x 1.42 Inches (99.0 x 97.0 x 36.0 mm)
Case Material	Vented Metal Enclosure
Weight	13.7 Oz (0.39 kg)

#### Reliability Specifications

Parameter	Conditions	Min.	Typ.	Max.	Units
MTBF	MIL HDBK 217F, 25°C, Gnd Benign	325			kHours
Safety Standards	IEN 60950, IEC 60950				
Vibration	10~500 Hz, 2G 10 min/1 Cycle. Period of 60 min each along X, Y & Z Axis				

## Model Selection Guide

Model Number	Input		Output				Output Voltage Tolerance (%)	Ripple & Noise (mV p-p)	Efficiency (% Typ)
	Current (A)		Voltage (VDC)		Current (A)				
	115 VAC	230 VAC	Rated	Adjust	Rated	Range			
MPE-25S-05	0.6	0.35	5.0	4.75 - 5.5	5.0	0 to 5.0	±2.0	50	72
MPE-25S-12	0.6	0.35	12.0	10.8 - 13.2	2.1	0 to 2.1	±1.0	100	76
MPE-25S-15	0.6	0.35	15.0	13.5 - 16.5	1.7	0 to 1.7	±1.0	100	77
MPE-25S-24	0.6	0.35	24.0	21.6 - 26.4	1.1	0 to 1.1	±1.0	100	80

### Notes:

- Output voltage tolerance includes the effects of set point accuracy, line regulation and load regulation.
- Ripple and noise is measured at 20 MHz bandwidth using a 12 inch twisted pair wire to connect to the power supply terminals. A 0.1  $\mu$ F and a 47  $\mu$ F capacitor are connected in parallel as close to the power supply terminals as possible.
- Overvoltage protection is provided by a "hiccup mode" circuit. The unit recovers automatically when the fault condition is removed.
- Overload protection is provided by fold-back current limiting. The unit recovers automatically when the fault condition is removed.
- Efficiency is measured with a 115 VAC input.
- It is recommended that a fuse be used on the input of a power supply for protection. For the MPE-25S series, a 2.5A/250 VAC slow blow should be used.

## Mechanical Dimensions

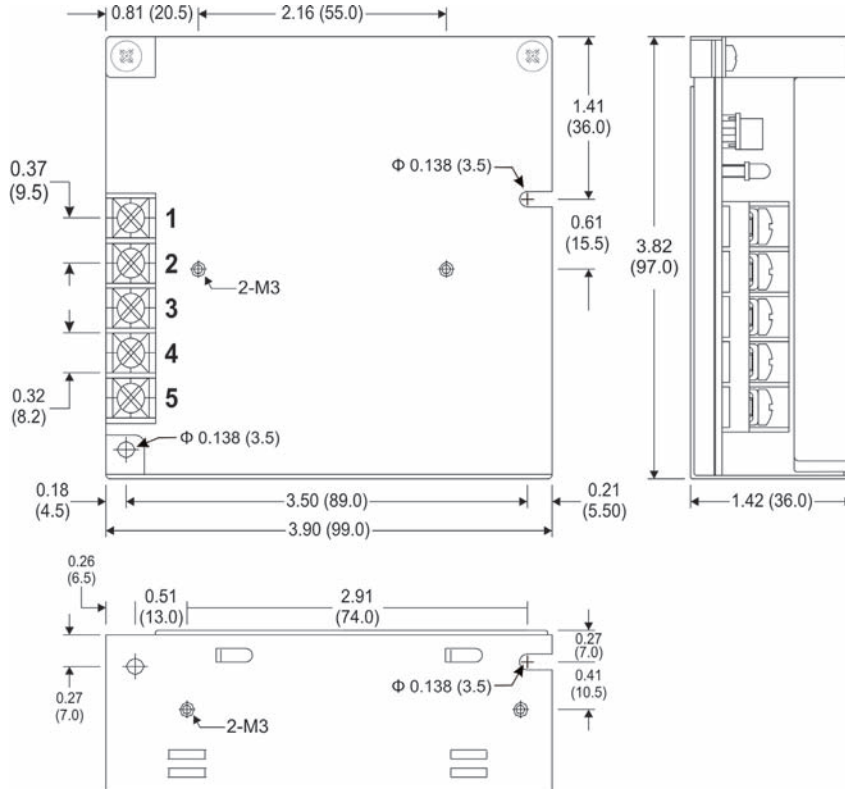

## Pin Connections

Pin	Function
1	-Vout
2	+Vout
3	AC-Ground
4	AC-Line
5	AC-Neutral

### Notes:

- All dimensions are typical in inches (mm)
- Tolerance x.xx = ±0.01 (±0.25)

## Derating Curve

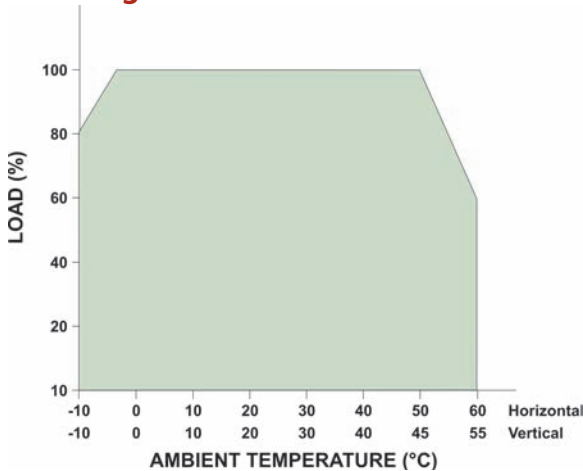

## Static Characteristics (24 Vout)

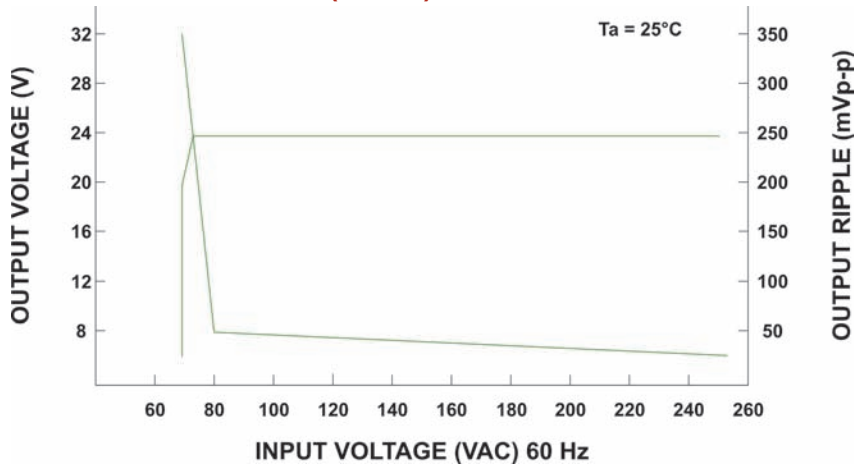

**MicroPower Direct**

[www.micropowerdirect.com](http://www.micropowerdirect.com)

292 Page Street Ste D Stoughton, MA 02072 • TEL: (781) 344-8226 • FAX: (781) 344-8481 • E-Mail: [sales@micropowerdirect.com](mailto:sales@micropowerdirect.com)