

GENERAL DESCRIPTION

The XRP7620 is a multi purpose 4-channel independently adjustable current sink driver. Optimized for LED backlighting and RGBW/RGBA color mixing applications, the XRP7620 can also be used as a generic software programmable current sink I/O expander.

Supporting an industry standard 2-wire I²C serial interface, the XRP7620 provides full independent control of each channel and can be programmed up to a current of 31.5mA in steps of 0.5mA. Uniform display brightness is ensured through better than 3% channel to channel current matching.

Five internal registers are provided to set operational configuration and individual channel current programming. A specific shutdown mode allows the device to retain the previously loaded configuration – operational and current programming – in order to be reused upon the next enabling.

The XRP7620 is designed to operate from a single cell lithium-ion battery or fixed 3.3V or 5.0V power rails and is available in a RoHS compliant, "green"/halogen free space saving 8-pin 2mmx3mm DFN package.

APPLICATIONS

- LCD Display & Keypad Backlighting
- Color Coded Indicator Lighting
- RGBW/RGBA Color Mixing
- Cell Phones & Handheld Devices
- Generic Current Sink I/O Expander

FEATURES

- 4-Channel LED Current Sink Driver
- Individual Channel Current Control
 - Up to 31.5mA per channel / 0.5mA Steps
 - 100mV Channel Dropout Voltage
- I²C Serial Interface
- 2.7V - 5.5V Input Voltage Range
- 3% Channel Current Matching
- Register Retention in Shutdown
- Shutdown Current <1 μ A
- Thermal and UVLO Built-in Protection
- RoHS Compliant, "Green"/Halogen Free 2x3mm 8-Pin DFN package

TYPICAL APPLICATION DIAGRAM

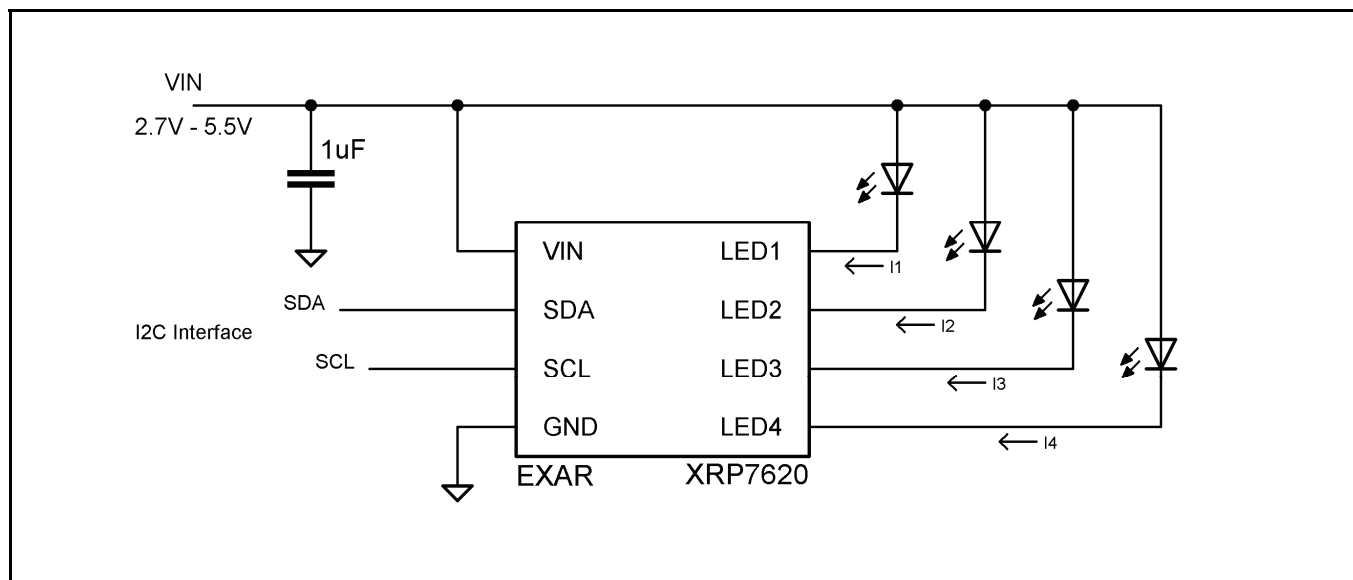

Fig. 1: XRP7620 Application Diagram



ABSOLUTE MAXIMUM RATINGS

These are stress ratings only and functional operation of the device at these ratings or any other above those indicated in the operation sections of the specifications below is not implied. Exposure to absolute maximum rating conditions for extended periods of time may affect reliability.

V_{IN} , SDA, SCL, LEDx -0.3V to 6.0V
 Storage Temperature..... -65°C to 150°C
 Power Dissipation Internally Limited (Note 1)
 Lead Temperature (Soldering, 10 sec) 300°C
 ESD Rating (Human Body Model) 2kV

OPERATING RATINGS

Input Voltage Range V_{IN}2.7V to 5.5V
 Junction Temperature Range-40°C to 100°C
 Thermal Resistance θ_{JA} 59°C/W

ELECTRICAL SPECIFICATIONS

Specifications with standard type are for an Operating Junction Temperature of $T_J = 25^\circ\text{C}$ only; limits applying over the full Operating Junction Temperature range are denoted by a “•”. Minimum and Maximum limits are guaranteed through test, design, or statistical correlation. Typical values represent the most likely parametric norm at $T_J = 25^\circ\text{C}$, and are provided for reference purposes only. Unless otherwise indicated, $V_{IN} = 2.7\text{V}$ to 4.6V , $C_{IN} = 1\mu\text{F}$, $T_A = -40^\circ\text{C}$ to 85°C , $T_J = -40^\circ\text{C}$ to 100°C .

Parameter	Min.	Typ.	Max.	Units	Conditions
Operating Input Voltage Range	2.7		5.5	V	•
Operating Input Current DAC=000000		30	50	μA	• $I_{LEDX}=0, V_{IN}=4.2\text{V}$
Operating Input Current		450	600	μA	• $I_{LED1}=I_{LED2}=I_{LED3}=I_{LED4}=10\text{mA}, V_{IN}=4.2\text{V}$
LED Current accuracy (includes Line Regulation)	-0.3		0.3	mA	• $V_{LED} = 0.2\text{V}$ to 2.7V $I_{LEDX} \leq 6\text{mA}$
	-5		5	%	$V_{LED} = 0.2\text{V}$ to 2.7V
	-8		8	%	• $I_{LEDX} > 6\text{mA}$
LED Current Matching	-3		3	%	• For same DAC setting $V_{LED} = 0.2\text{V}$ to 2.7V , Note 2
Line Regulation			1	%/V	• Measured as $\Delta I_{OUT} / I_{OUT_AVG} / \Delta V$ $V_{LED} = 0.2\text{V}$ to 2.7V , Note 3
Current DAC Resolution		6		Bit	
Current for DAC=000000			2	μA	• Applies to all LEDs
Current for DAC=000001	0.35	0.50	0.65	mA	Applies to all LEDs
Maximum LED Current DAC=111111	30.50	31.75	33.00	mA	Applies to all LEDs
Maximum Current Change Settling Time			2	μs	• For changes between any DAC code 000001 and higher. Current must change within this time after the last bit of LED data. $V_{IN}=2.7$ to 5.5V
		60	150	μs	Applies to changes between DAC code 000000 and higher or change from 0 to 1 for STATUS bits B5-B2 (channel enable). Current must change within this time after the last bit of LED data. $V_{IN}=2.7$ to 5.5V
Current Source Dropout Voltage		0.1	0.15	V	• $I_{LED}=20\text{mA}$; The voltage where LED current decreases 3% from nominal value at $V_{LED} = 1\text{V}$. $V_{IN}=2.7$ to 5.5V
Shutdown Supply Current		0.01	1	μA	$V_{IN}=4.2\text{V}$
Shutdown Supply Current			5	μA	$V_{IN}=4.2\text{V}, T_A=85^\circ\text{C}$
Thermal Shutdown Die Temperature	125	150	175	$^\circ\text{C}$	Regulator turns off



Parameter	Min.	Typ.	Max.	Units		Conditions
Thermal Shutdown Hysteresis		15		°C		Regulator turns on
SDA, SCL Input Logic Low Voltage			0.4	V	•	
SDA, SCL Input Logic High Voltage	1.6			V	•	
SDA, SCL Timeout for Shutdown		90	150	ms		

I²C SPECIFICATION

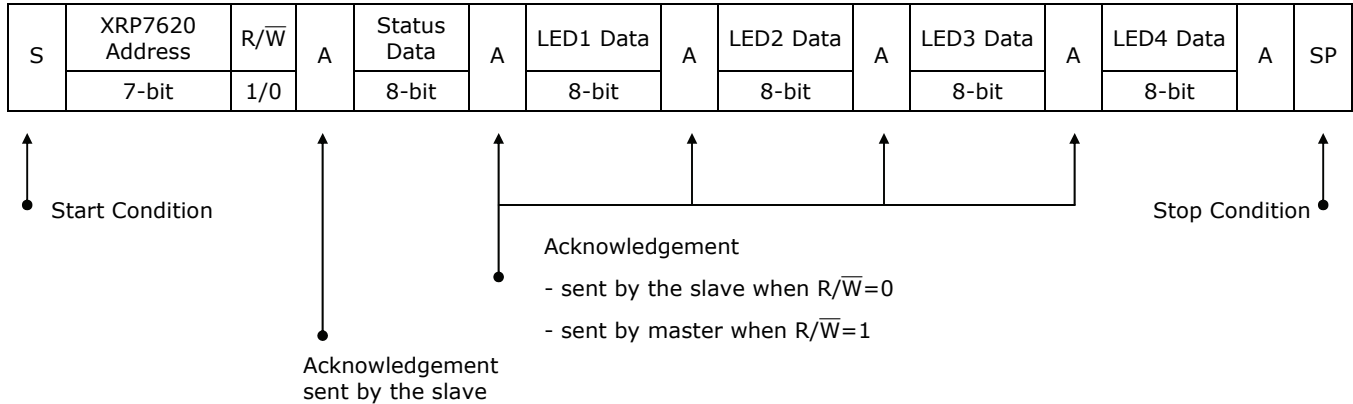

Fig. 2: Data Input Format

I²C TIMING CHARACTERISTICS

Unless otherwise indicated, $V_{IN} = 2.7V$ to $4.6V$, $C_{IN} = 1\mu F$, $T_A = -40^\circ C$ to $85^\circ C$, $T_J = -40^\circ C$ to $100^\circ C$.

Parameter	Symbol	Min.	Typ.	Max.	Units	Conditions
Serial Clock Frequency	f_{SCL}			400	KHz	
Bus Free Time between a STOP and a START	t_{BUF}	1.3			μs	
Hold Time, Repeated START Condition	t_{HD_STA}	0.6			μs	
STOP Condition Setup Time	t_{SU_STO}	0.6			ms	
Data Hold Time	$t_{HD_DAT(OUT)}$	225		900	ns	
Input Data Hold Time	$t_{HD_DAT(IN)}$	0		900	ns	
Data Setup Time	t_{SU_DAT}	100			ns	
SCL Clock Low Period	t_{LOW}	1.3			ms	
SCL Clock High Period	t_{HIGH}	0.6			ms	
Rise Time of Both SDA and SCL Signals, receiving	t_R	$20+0.1C_b$		300	ns	Note 4,5
Fall Time of Both SDA and SCL Signals, Receiving	t_F	$20+0.1C_b$		300	ns	Note 4,5
Fall Time of SDA Transmitting	t_{F_TX}	$20+0.1C_b$		250	ns	Note 4,5, 6
Pulse Width of Spike Suppressed	t_{SP}	0		50	ns	Note 7
Capacitive Load for each Bus Line	C_b			400	pF	Note 4
I ² C Startup Time after UVLO clears	t_{SRT}			1	μs	Note 4

Note 1: All parameters tested at $T_A=25^\circ C$. Specifications over temperature are guaranteed by design.

Note 2: LED current matching is calculated by this equation:

$$\frac{I_{LED} - I_{AVG}}{I_{AVG}} \times 100\% \text{ Where } I_{AVG} \text{ is the average current of 4 channels.}$$

Note 3: Ling regulation is calculated by this equation:

$$\frac{I_2 - I_1}{I_{AVG}} \times \frac{1}{\Delta V} \times 100\% \quad \text{Where } I_1 \text{ and } I_2 \text{ is the current at different } V_{IN}.$$

Note 4: Guaranteed by design.

Note 5: C_b = total capacitance of one bus line in pF. t_R and t_F measured between 0.3 x V_{DD} and 0.7 x V_{DD}.

Note 6: I_{SINK} ≤ 6mA. C_b = total capacitance of one bus line in pF. t_R and t_F measured between 0.3 x V_{DD} and 0.7 V_{DD}.

Note 7: Input filters on the SDA and SCL inputs suppress noise spikes less than 50ns.

BLOCK DIAGRAM

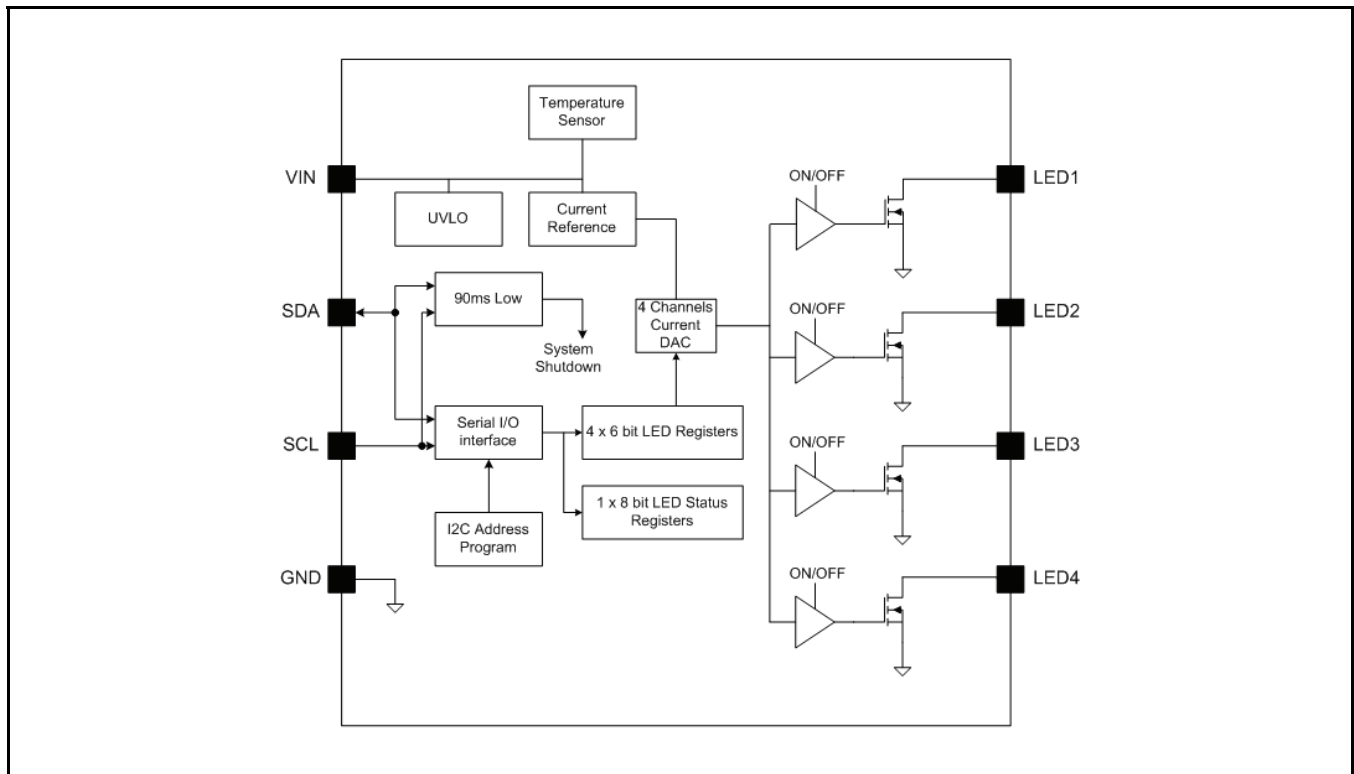

Fig. 3: XRP7620 Block Diagram

PIN ASSIGNMENT

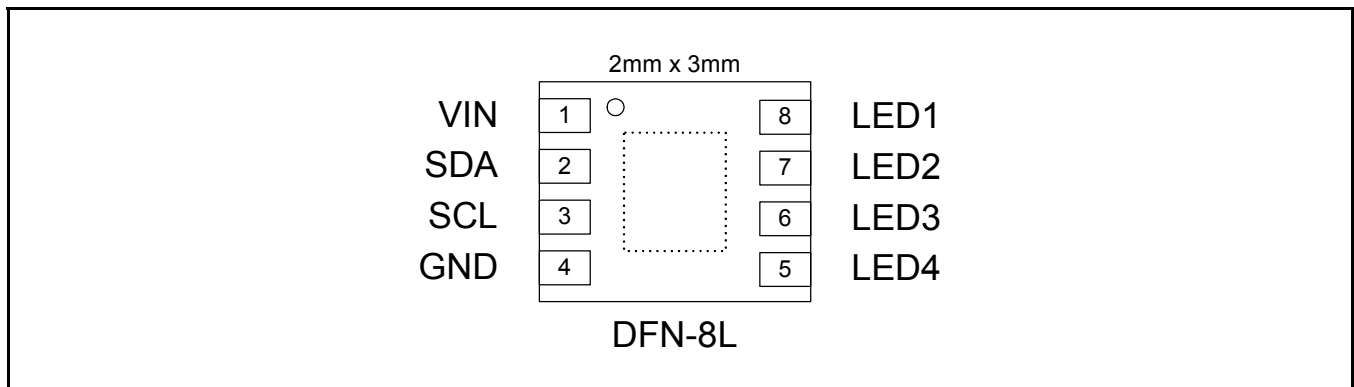

Fig. 4: XRP7620 Pin Assignment

**PIN DESCRIPTION**

Name	Pin Number	Description
VIN	1	Connect a 1 μ F decoupling capacitor between this pin and the ground pin (pin 4).
SDA	2	I2C Interface Serial Data Input-Output.
SCL	3	I2C Interface Serial Clock Input.
GND	4	Ground Signal.
LED4	5	LED 4 Input. Connect a LED between this pin and VIN. Current Value is set by the serial interface.
LED3	6	LED 3 Input. Connect a LED between this pin and VIN. Current Value is set by the serial interface.
LED2	7	LED 2 Input. Connect a LED between this pin and VIN. Current Value is set by the serial interface.
LED1	8	LED 1 Input. Connect a LED between this pin and VIN. Current Value is set by the serial interface.

ORDERING INFORMATION

Part Number	Temperature Range	Marking	Package	Packing Quantity	Note 1	I ² C Address
XRP7620IH-F	-40°C ≤ T _j ≤ +100°C	7620I YYWWFX	DFN-8L	Bulk	Green Halogen Free	0x70
XRP7620IHTR-F	-40°C ≤ T _j ≤ +100°C	7620I YYWWFX	DFN-8L	3K/Tape & Reel	Green Halogen Free	0x70
XRP7620EVB	XRP7620 Evaluation Board					

“YY” = Year - “WW” = Work Week - “F” = Green/Halogen Free Package - “X” = Lot Number

XRP7620 may be ordered with alternative I²C addresses - Contact your Exar Sales Representative for further information.

Typical Performance Characteristics

All data taken at $V_{IN} = 2.7V$ to $5.5V$, $T_J = T_A = 25^\circ C$, unless otherwise specified - Schematic and BOM from Application Information/Theory of Operation section of this datasheet.

CH₁ = SDA, CH₂ = SCL, CH₄ = I_{LED} = 20mA/div

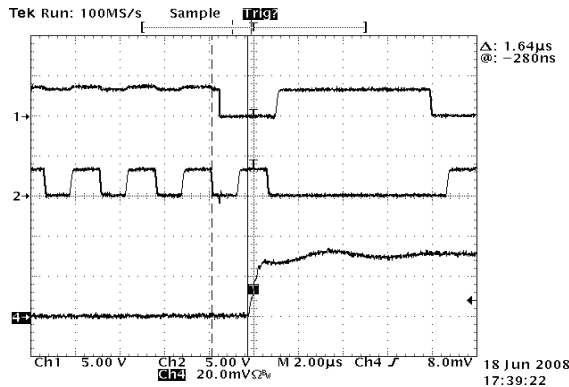

Fig. 5: LED Current Change Settling Time From 0.5mA to 31.5mA

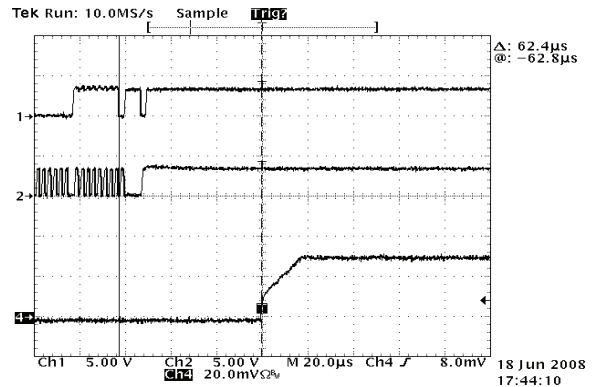

Fig. 6: LED Current Change Settling Time From 0mA to 31.5mA

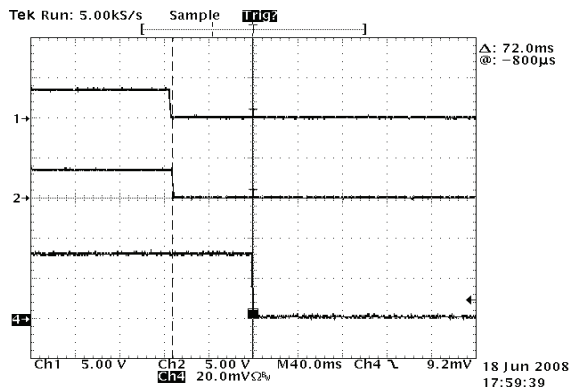

Fig. 7: SDA, SCL Timeout for Shutdown

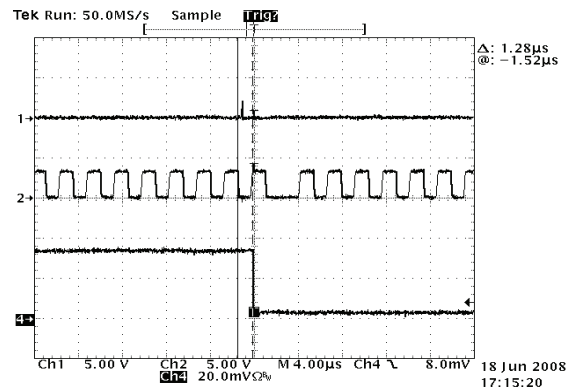

Fig. 8: LED Current Change Settling Time From DAC 31.5mA to 0mA

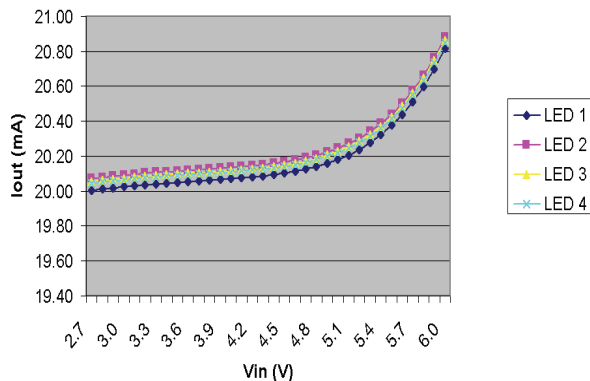

Fig. 9: Line Regulation DAC = 101000 (20mA)

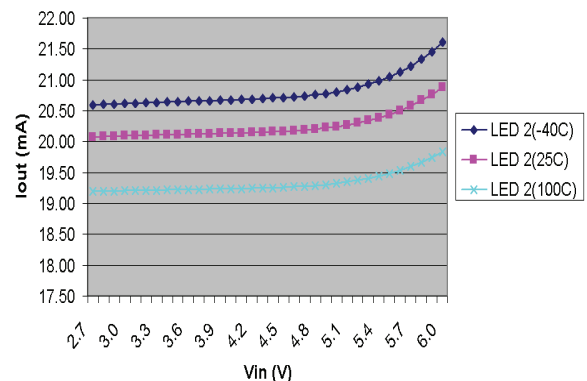

Fig. 10: Line Regulation LED1 DAC = 101000 (20mA)

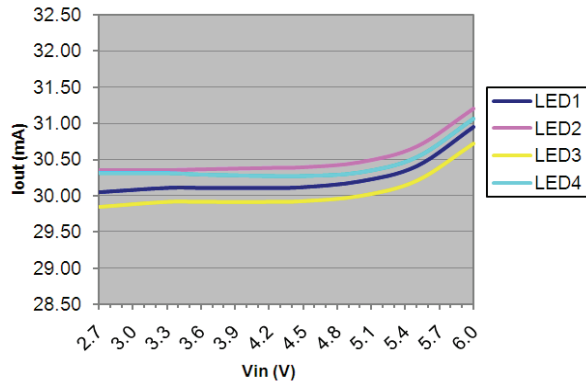

Fig. 11: Line Regulation @ $T_A = 25^\circ\text{C}$
DAC = 111100 (30mA)

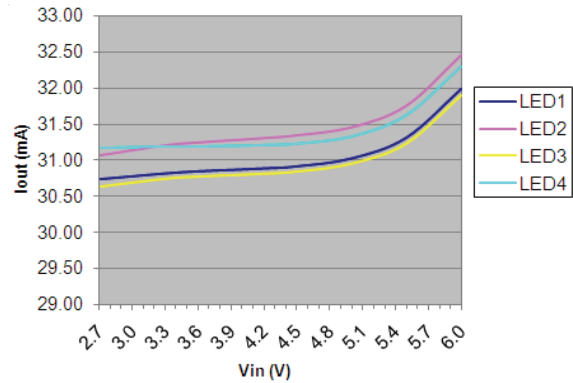

Fig. 12: Line Regulation @ $T_A = -40^\circ\text{C}$
DAC = 111100 (30mA)

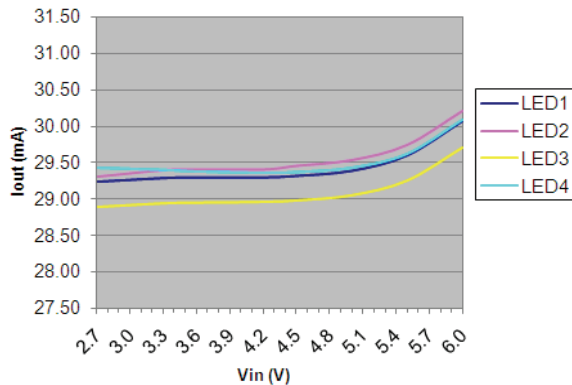

Fig. 13: Line Regulation @ $T_A = 85^\circ\text{C}$
DAC = 111100 (30mA)

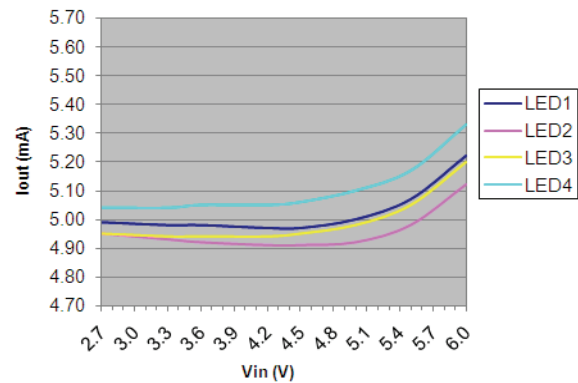

Fig. 14: Line Regulation @ $T_A = 25^\circ\text{C}$
DAC = 001010 (5mA)

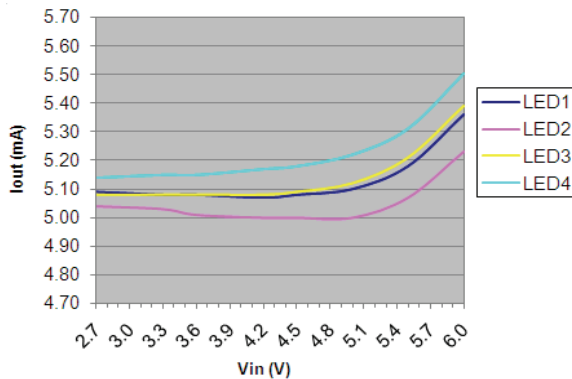

Fig. 15: Line Regulation @ $T_A = -40^\circ\text{C}$
DAC = 001010 (5mA)

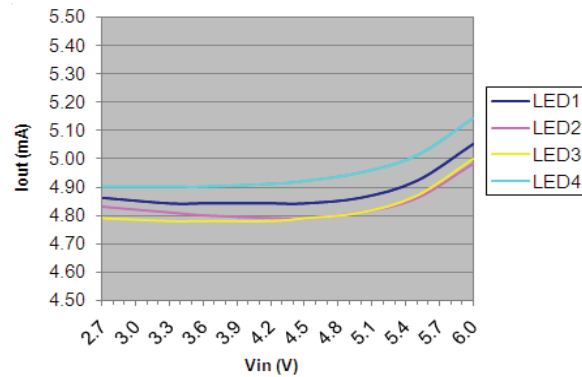

Fig. 16: Line Regulation @ $T_A = 85^\circ\text{C}$
DAC = 001010 (5mA)



THEORY OF OPERATION

I²C SERIAL INTERFACE

The XRP7620 has five data registers which can be programmed serially through the I²C interface. The first register is a status register which has two bits used for shutdown/power up options, 4 bits used for individual LED ON/OFF control, one bit for over-temperature readback and one bit for undervoltage lockout readback. The next four registers are used to set the brightness levels of the four LEDs.

	B7	B6	B5	B4	B3	B2	B1	B0
Status	WZ	WP	LED4	LED3	LED2	LED1	OVT	UVL
LED1	D5	D4	D3	D2	D1	D0	-	-
LED2	D5	D4	D3	D2	D1	D0	-	-
LED3	D5	D4	D3	D2	D1	D0	-	-
LED4	D5	D4	D3	D2	D1	D0	-	-

Table 1: XRP7620 I²C Register Bit Map

Status Register

Status register bits B7 and B6

The following table defines the states for bits B7 and B6 of the STATUS register. They are used to put the XRP7620 into shutdown, standby, or active mode.

WZ	WP	State	I_q	LED Driver
0	0	Shutdown and reset registers to 00000000	0μA	Off
0	1	Shutdown Keeps registers contents	0μA	Off
1	0	Standby Keeps registers contents	30μA	Off
1	1	Active	Active	On

Table 2: XRP7620 Status Register Bits B7 and B6

Status register bits B5-B2

These bits are to control the LED On/Off individually. Putting 1 (logic high) will enable the driver and putting 0 (logic low) will disable the driver.

Status register bits B1 and B0

These bits are the readback bits. Their values are 0 for normal operations. If over-temperature is detected, B1=1, and If undervoltage is detected, B0=1. The UVL threshold is approximately 2.4V.

LED Registers (x4)

LED register bits B7-B2

In LED registers bits B7, B6, B5, B4, B3 and B2 represent the DAC codes D5-D0 used to set the LED current in the four LEDs, and B1 and B0 are not used. The following table lists the DAC codes and the corresponding current for each channel in mA:

B7-B2	Current mA	B7-B2	Current mA
000000	0	100000	16.0
000001	0.5	100001	16.5
000010	1.0	100010	17.0
000011	1.5	100011	17.5
000100	2.0	100100	18.0
000101	2.5	100101	18.5
000110	3.0	100110	19.0
000111	3.5	100111	19.5
001000	4.0	101000	20.0
001001	4.5	101001	20.5
001010	5.0	101010	21.0
001011	5.5	101011	21.5
001100	6.0	101100	22.0
001101	6.5	101101	22.5
001110	7.0	101110	23.0
001111	7.5	101111	23.5
010000	8.0	110000	24.0
010001	8.5	110001	24.5
010010	9.0	110010	25.0
010011	9.5	110011	25.5
010100	10.0	110100	26.0
010101	10.5	110101	26.5
010110	11.0	110110	27.0
010111	11.5	110111	27.5
011000	12.0	111000	28.0
011001	12.5	111001	28.5
011010	13.0	111010	29.0
011011	13.5	111011	29.5
011100	14.0	111100	30.0
011101	14.5	111101	30.5
011110	15.0	111110	31.0
011111	15.5	111111	31.5

Table 3: LED Current DAC Settings

**Addressing and Writing Data**

To write data to the XRP7620 one of the following two cycles must be followed:

Easy shutdown/startup sequence

[Slave Address with write bit][Data for Status]

Full shutdown/startup sequence

[Slave Address with write bit][Data for Status][Data for LED1][Data for LED2][Data for LED3][Data for LED4]

Addressing and Reading Data

To read data from the XRP7620 the following data cycle must be obeyed:

[Slave Address with read bit][Data for Status][Data for LED1][Data for LED2][Data for LED3][Data for LED4]

SHUTDOWN OPTIONS

The XRP7620 can be placed in shutdown mode by holding both the SDA and SCL lines low for a minimum of typically 90ms. This puts a zero in bit 7 and bit 6 of the status register, which in turn will reset all bits of all registers. After any shutdown, the part can only be restarted through the I²C bus.

SHORTED LEDs

If an LED shorts to the extent that the LED pin comes within 0.7V of V_{IN} the LED channel may turn off because the drive circuitry effectively is in a dropout condition. The exact voltage will vary with programmed LED current.

PARALELLING CURRENT SINKS

The maximum programmable current per LED pin is 31.5mA. If a higher current is desired, 2, 3, or all 4 LED pins may be connected to share current. Although it is technically possible to program the channels to different values to add up to the desired total, it is recommended that paralleled channels be programmed to the same value.



PACKAGE SPECIFICATION

8-PIN DFN

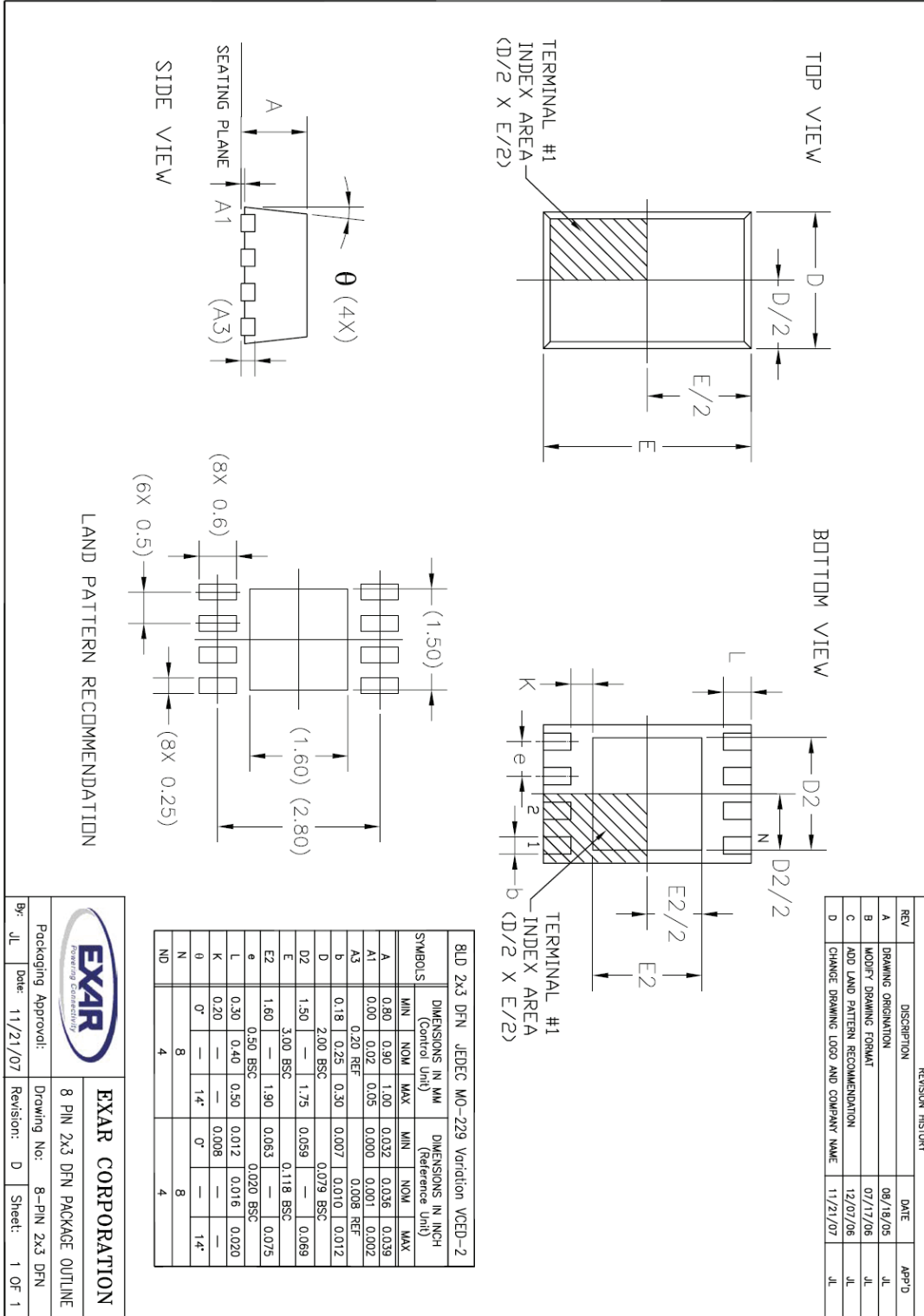



REVISION HISTORY

Revision	Date	Description
1.0.0	06/04/2009	Initial release of datasheet

FOR FURTHER ASSISTANCE

Email:

customersupport@exar.com

Exar Technical Documentation:

<http://www.exar.com/TechDoc/default.aspx?>



EXAR CORPORATION

HEADQUARTERS AND SALES OFFICES

48720 Kato Road

Fremont, CA 94538 – USA

Tel.: +1 (510) 668-7000

Fax: +1 (510) 668-7030

www.exar.com

NOTICE

EXAR Corporation reserves the right to make changes to the products contained in this publication in order to improve design, performance or reliability. EXAR Corporation assumes no responsibility for the use of any circuits described herein, conveys no license under any patent or other right, and makes no representation that the circuits are free of patent infringement. Charts and schedules contained here in are only for illustration purposes and may vary depending upon a user's specific application. While the information in this publication has been carefully checked; no responsibility, however, is assumed for inaccuracies.

EXAR Corporation does not recommend the use of any of its products in life support applications where the failure or malfunction of the product can reasonably be expected to cause failure of the life support system or to significantly affect its safety or effectiveness. Products are not authorized for use in such applications unless EXAR Corporation receives, in writing, assurances to its satisfaction that: (a) the risk of injury or damage has been minimized; (b) the user assumes all such risks; (c) potential liability of EXAR Corporation is adequately protected under the circumstances.

Reproduction, in part or whole, without the prior written consent of EXAR Corporation is prohibited.