

Features:

- Advanced trench process technology
- avalanche energy, 100% test
- Fully characterized avalanche voltage and current

Description:

The SSF1016 is a new generation of high voltage and low current N-Channel enhancement mode trench power MOSFET. This new technology increases the device reliability and electrical parameter repeatability. SSF1016 is assembled in high reliability and qualified assembly house.

Application:

- Power switching application

ID =75A
BV=100V
Rdson=16mΩ(Max.)

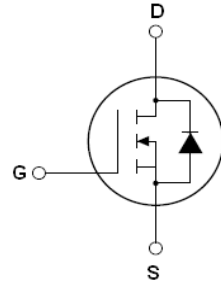
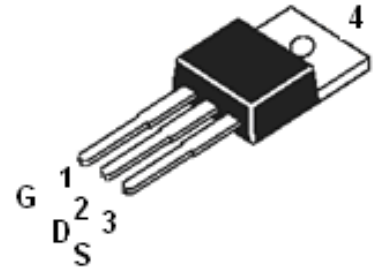
SSF1016 TOP View (T0-220)

Absolute Maximum Ratings

	Parameter	Max.	Units
$I_D@T_c=25\text{ C}$	Continuous drain current, $V_{GS}@10V$	75	A
$I_D@T_c=100\text{ C}$	Continuous drain current, $V_{GS}@10V$	65	
I_{DM}	Pulsed drain current ①	300	
$P_D@T_c=25\text{ C}$	Power dissipation	227	W
	Linear derating factor	1.5	W/ C
V_{GS}	Gate-to-Source voltage	± 20	V
E_{AS}	Single pulse avalanche energy ②	380	mJ
E_{AR}	Repetitive avalanche energy	TBD	mJ
dv/dt	Peak diode recovery voltage	31	v/ns
T_J T_{STG}	Operating Junction and Storage Temperature Range	-55 to +150	°C

Thermal Resistance

	Parameter	Min.	Typ.	Max.	Units
$R_{\theta JC}$	Junction-to-case	—	0.55	—	°C/W
$R_{\theta JA}$	Junction-to-ambient	—	—	62	

Electrical Characteristics @ $T_J=25\text{ C}$ (unless otherwise specified)

	Parameter	Min.	Typ.	Max.	Units	Test Conditions
BV_{DSS}	Drain-to-Source breakdown voltage	100	—	—	V	$V_{GS}=0V, I_D=250\mu A$
$R_{DS(on)}$	Static Drain-to-Source on-resistance	—	11	16	mΩ	$V_{GS}=10V, I_D=30A$
$V_{GS(th)}$	Gate threshold voltage	2.0	—	4.0	V	$V_{DS}=V_{GS}, I_D=250\mu A$
I_{DSS}	Drain-to-Source leakage current	—	—	2	μA	$V_{DS}=100V, V_{GS}=0V$
		—	—	10		$V_{DS}=100V, V_{GS}=0V, T_J=150\text{ C}$
I_{GSS}	Gate-to-Source forward leakage	—	—	100	nA	$V_{GS}=20V$
	Gate-to-Source reverse leakage	—	—	-100		$V_{GS}=-20V$

Q_g	Total gate charge	—	90		nC	$I_D=30A, V_{GS}=10V$ $V_{DD}=30V$
Q_{gs}	Gate-to-Source charge	—	20	—		
Q_{gd}	Gate-to-Drain ("Miller") charge	—	31	—		
$t_{d(on)}$	Turn-on delay time	—	18.2		nS	$V_{DD}=30V$ $I_D=2A, R_L=15\Omega$ $R_G=2.5\Omega$ $V_{GS}=10V$
t_r	Rise time	—	15.6			
$t_{d(off)}$	Turn-Off delay time	—	70.5			
t_f	Fall time	—	13.8			
C_{iss}	Input capacitance	—	3150		pF	$V_{GS}=0V$ $V_{DS}=25V$ $f=1.0MHZ$
C_{oss}	Output capacitance	—	350			
C_{rss}	Reverse transfer capacitance	—	240			

Source-Drain Ratings and Characteristics

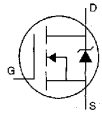
	Parameter	Min.	Typ.	Max.	Units	Test Conditions
I_S	Continuous Source Current (Body Diode)	—	—	75	A	MOSFET symbol showing the integral reverse p-n junction diode. 
I_{SM}	Pulsed Source Current (Body Diode) ①	—	—	300		
V_{SD}	Diode Forward Voltage	—	—	1.3	V	$T_J=25C, I_S=60A, V_{GS}=0V$ ③
t_{rr}	Reverse Recovery Time	—	57	—	nS	$T_J=25C, I_F=75A$
Q_{rr}	Reverse Recovery Charge	—	107	—	μC	$di/dt=100A/\mu s$ ③
t_{on}	Forward Turn-on Time	Intrinsic turn-on time is negligible (turn-on is dominated by $L_S + L_D$)				

Notes:

- ① Repetitive rating; pulse width limited by max junction temperature.
- ② Test condition: $L = 0.3mH, V_{DD} = 50V, I_D=37A$
- ③ Pulse width $\leq 300\mu s$, duty cycle $\leq 1.5\%$; $R_G = 25\Omega$ Starting $T_J = 25^\circ C$

EAS Test Circuit:

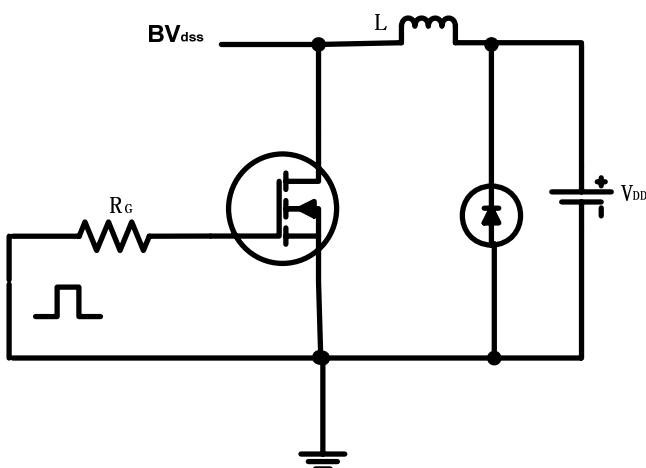

Gate Charge Test Circuit:

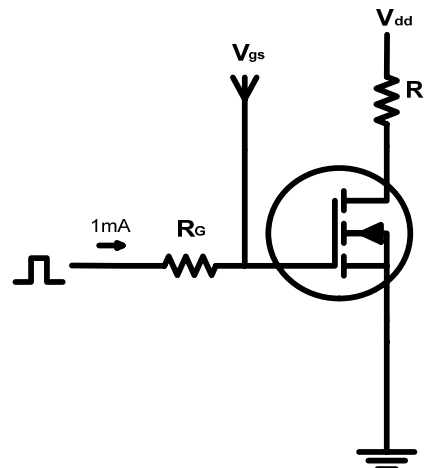

Switch Time Test Circuit:

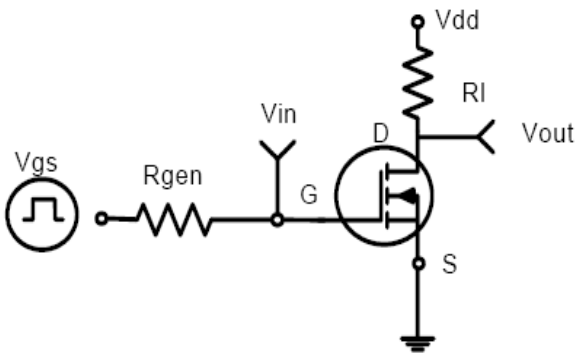

Switch Waveform:

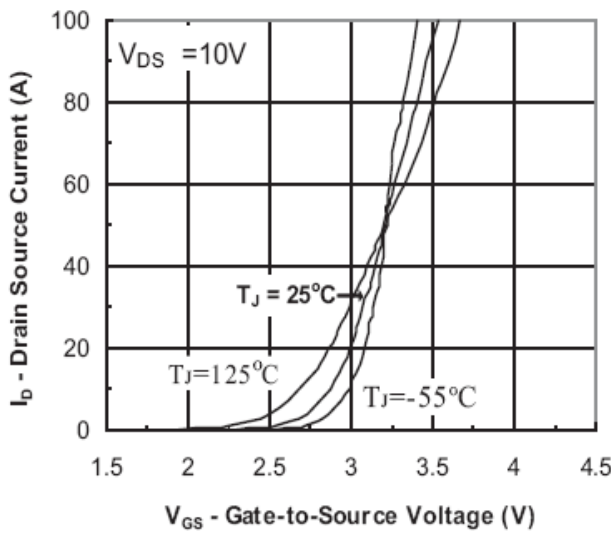
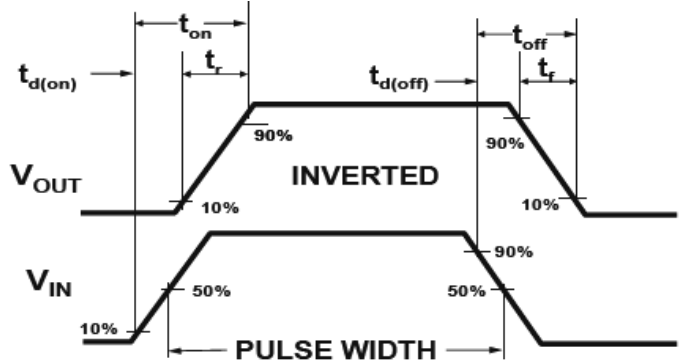

Transfer Characteristic

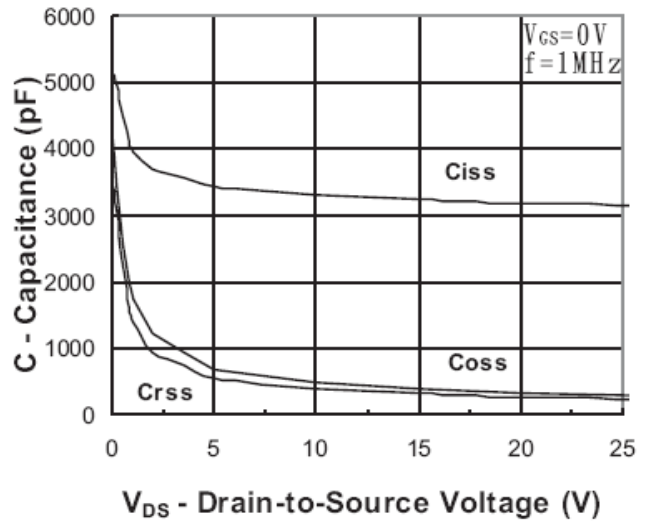

Capacitance

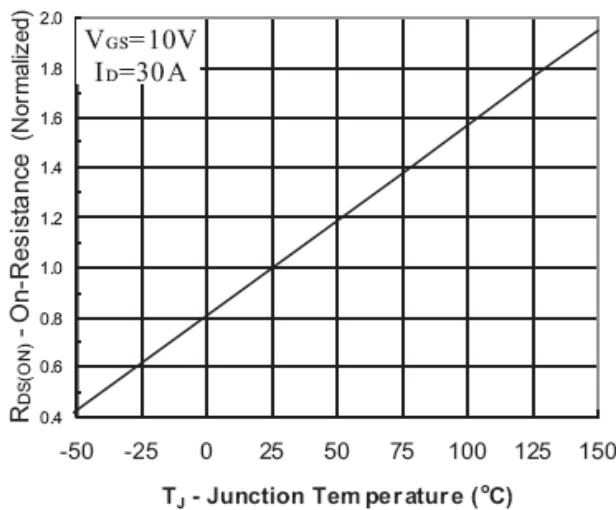

On Resistance vs Junction Temperature

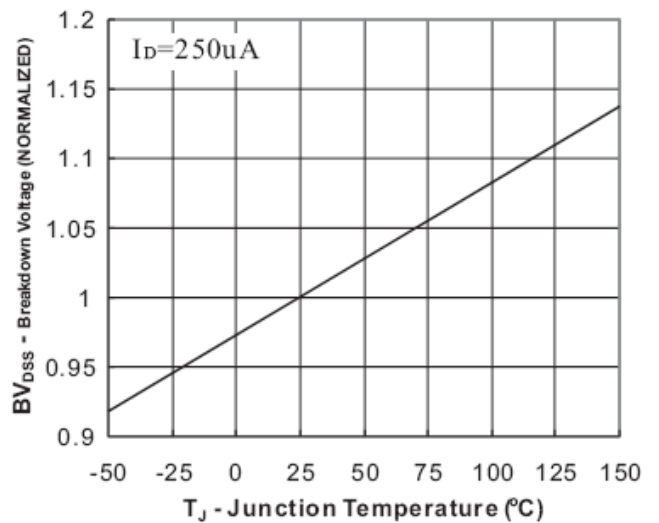

Breakdown Voltage vs Junction Temperature

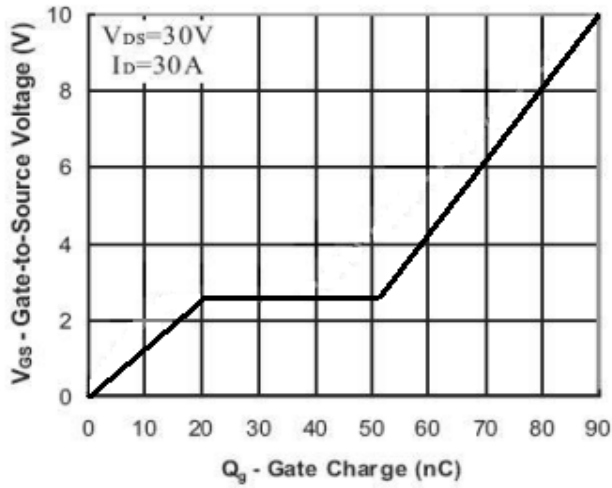

Gate Charge

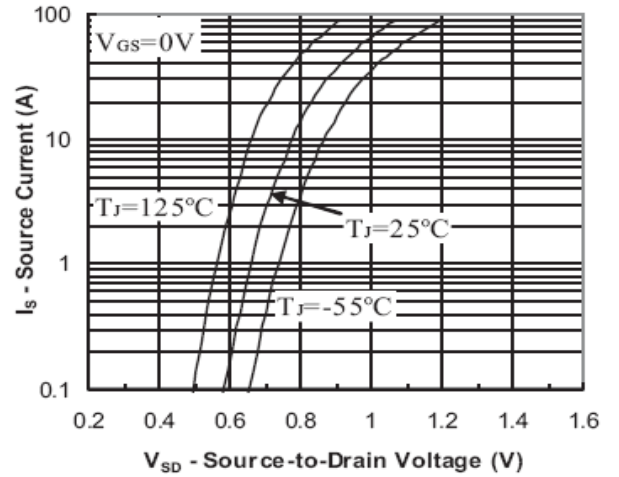

Source-Drain Diode Forward Voltage

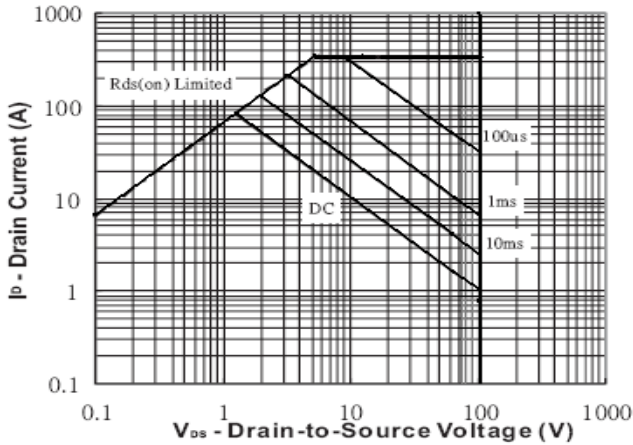

Safe Operation Area

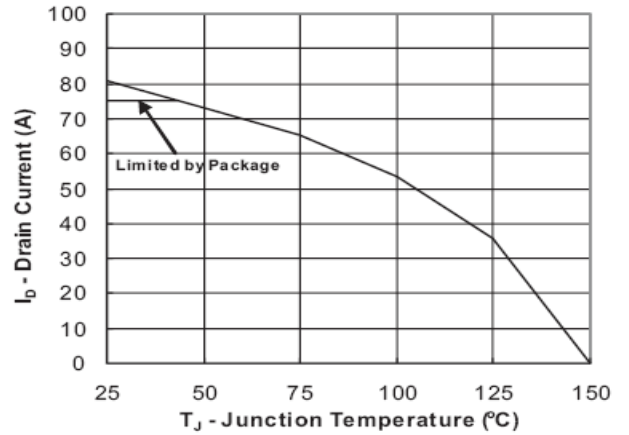

Max Drain Current vs Junction

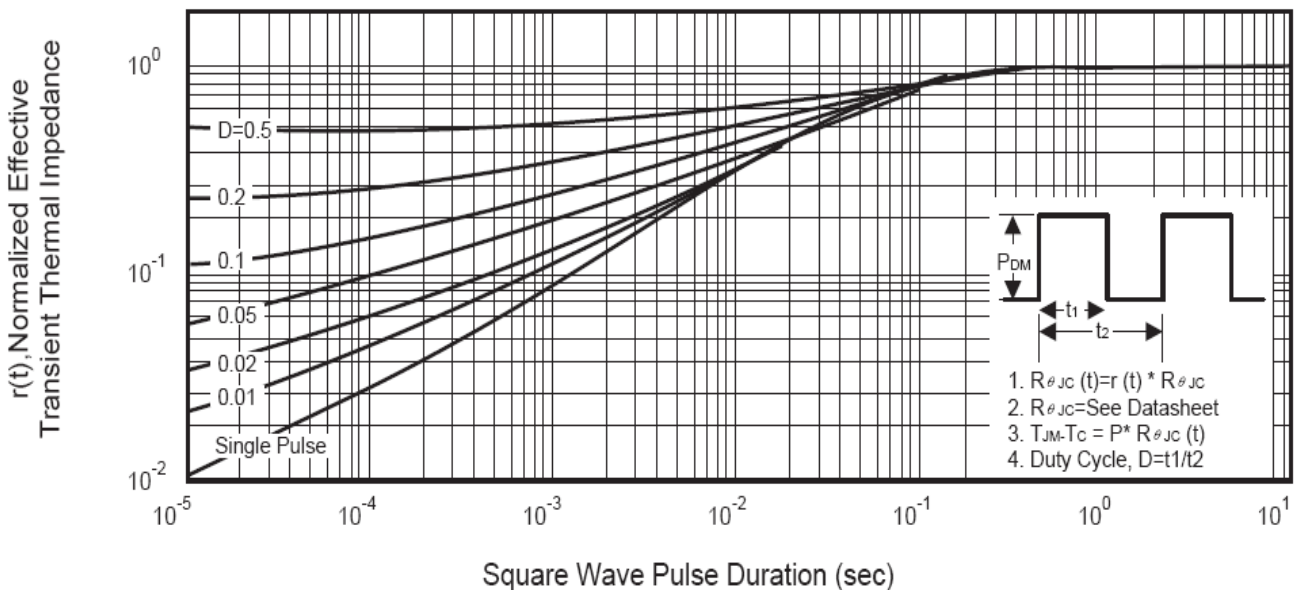

Transient Thermal Impedance Curve

TO-220 MECHANICAL DATA:

