

Features

- Meets wetting (sealing) current requirements per ITU-T G.991.2
- Integrated bridge rectifier for polarity correction
- Uses inexpensive opto-coupler for DC signalling
- Electronic inductor, breakover, and latch circuits
- Current limiting and excess power protection circuits
- ANSI SHDSL and ISDN compatible
- MLT and SARTS compatible
- Compatible with portable test sets
- Excellent linearity
- Compatible with GlobespanVirata and Conexant SHDSL transceiver chip set families
- Small SOIC or DFN Package
- DFN package 60 percent smaller than SOIC
- SOIC is pin compatible with Agere LH1465AAE

Applications

- Router and bridge customer premises equipment
- Leased line equipment
- T1/E1 network line cards and repeaters
- Network Termination 1 (NT1) equipment
- Mechanized Loop Test (MLT) networks
- Switched Access Remote Test System (SARTS) networks

Description

The CPC1465 is a DC termination IC used in Single-pair High-speed Digital Subscriber Line (SHDSL) and Integrated Services Digital Network subscriber line (ISDN) equipment. It provides a polarity insensitive DSL loop sealing current DC termination with a recognizable device signature for MLT systems. The CPC1465 passes low frequency ISDN network signalling information via an inexpensive optocoupler to the NT1's internal control logic.

Ordering Information

Part Number	Description
CPC1465D	DC Termination IC, 16-pin SOIC in tubes, 47/tube
CPC1465DTR	DC Termination IC, 16-pin SOIC tape and reel, 1000/reel
CPC1465M	DC Termination IC, 16-pin DFN in tubes, 52/tube
CPC1465MTR	DC Termination IC, 16-pin DFN tape and reel, 1000/reel

Figure 1. CPC1465 Typical 2-Wire DC Termination Application

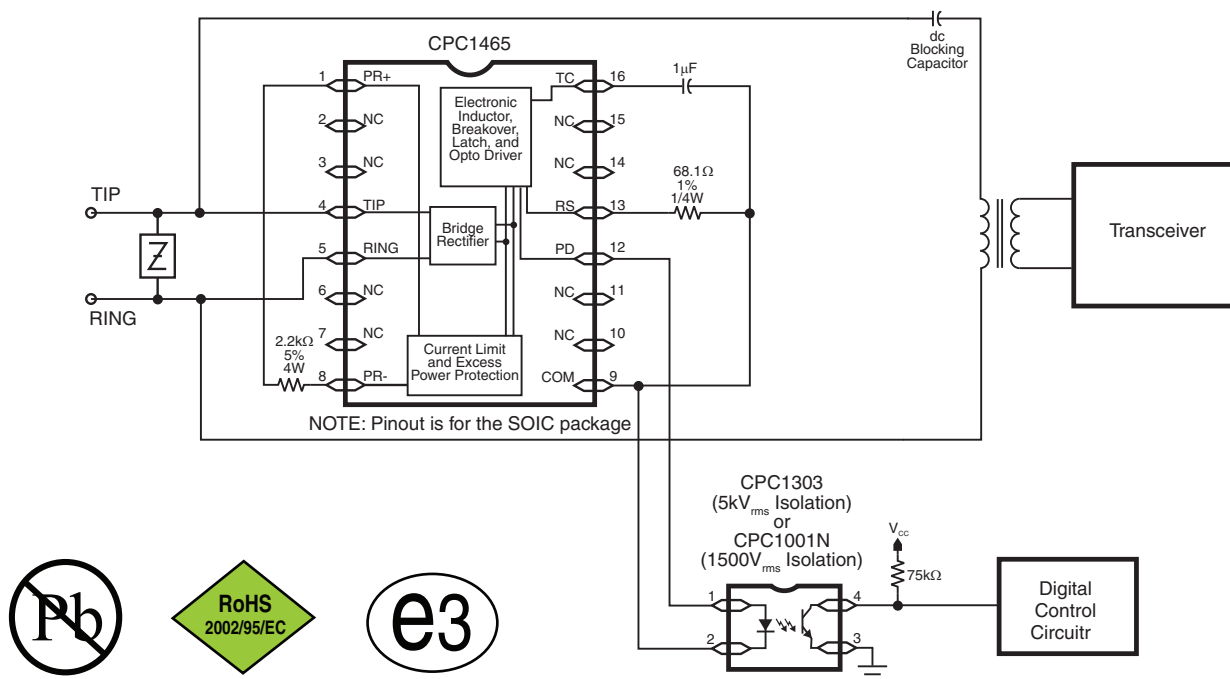

1. Specifications	3
1.1 Package Pinout	3
1.2 Pin Description	3
1.3 Absolute Maximum Ratings	3
1.4 Electrical Characteristics	4
1.4.1 DC Characteristics, Normal Operation	4
1.4.2 AC Characteristics, Normal Operation	4
1.4.3 Transition Characteristics, Normal Operation	4
1.5 Application Signalling Characteristics	8
1.5.1 LED Trigger Characteristics During MLT Signalling	8
1.5.2 LED Trigger Characteristics During Dial Test Set Signalling	8
2. Functional Description	10
2.1 Introduction	10
2.2 Surge Protection	10
2.3 Bridge Rectifier	10
2.4 State Transitions	10
2.4.1 Activation - On-State	10
2.4.2 Deactivation - Off-State	10
2.5 Photo-Diode (PD) Output Behavior	11
2.6 On-State Behavior	11
2.6.1 Typical Conditions	11
2.6.2 Over-Voltage Conditions	11
3. Manufacturing Information	12
3.1 Mechanical Dimensions	12
3.1.1 SOIC	12
3.1.2 DFN	13
3.2 Printed Circuit Board Layout Pattern	14
3.2.1 SOIC	14
3.2.2 DFN	14
3.3 Tape and Reel Packaging	14
3.3.1 SOIC	14
3.3.2 DFN	15
3.4 Soldering	15
3.4.1 Moisture Reflow Sensitivity	15
3.4.2 Reflow Profile	15
3.5 Washing	15

1. Specifications

1.1 Package Pinout

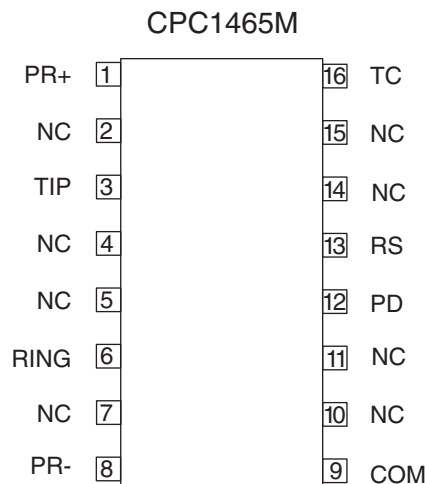
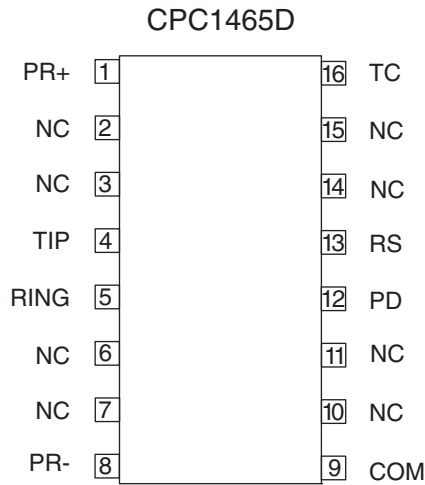

1.2 Pin Description

SOIC Pin	DFN Pin	Name	Description
1	1	PR+	Protection resistor positive side
2	2	NC	No connection
3		NC	No connection
4	3	TIP	Tip lead
	4	NC	No connection
	5	NC	No connection
5	6	RING	Ring lead
6		NC	No connection
7	7	NC	No connection
8	8	PR-	Protection resistor negative side
9	9	COM	Common
10	10	NC	No connection
11	11	NC	No connection
12	12	PD	Photo-diode (LED input current)
13	13	RS	Current limiting resistor
14	14	NC	No connection
15	15	NC	No connection
16	16	TC	Timing capacitor

1.3 Absolute Maximum Ratings

Parameter	Minimum	Maximum	Unit
Maximum Voltage (T to R, R to T)*	-	300	V
Power dissipation	-	1	W
Operating temperature	-40	+85	°C
Operating relative humidity	5	95	%
Storage temperature	-40	+125	°C

*Clare recommends the use of room-temperature-vulcanizing silicone RTV sealant on the SOIC package tip and ring pins (pins 4 and 5) to guard against the possibility of arcing.

Electrical absolute maximum ratings are at 25°C.

Absolute maximum ratings are stress ratings. Stresses in excess of these ratings can cause permanent damage to the device. Functional operation of the device at conditions beyond those indicated in the operational sections of this data sheet is not implied.

1.4 Electrical Characteristics

Unless otherwise specified, minimum and maximum values are guaranteed by production testing requirements. Typical values are characteristic of the device and are the result of engineering evaluations. In addition, typical values are provided for

informational purposes only and are not part of the testing requirements.

All electrical specifications are provided for $T_A=25^\circ\text{C}$

1.4.1 DC Characteristics, Normal Operation

For operational templates: (see Figure 2 on page 5) and (see Figure 3 on page 5).

Parameter	Conditions	Symbol	Minimum	Typical	Maximum	Unit
Activate/Non-activate Voltage	Off State	V_{AN}	30.0	35.0	39.0	V
Breakover current	-	I_{BO}	-	0.5	1	mA
DC Voltage drop	Active State, $1\text{ mA} \leq I_{SL} \leq 20\text{ mA}$	V_{ON}	-	12.5	15	V
DC leakage current	$V_{OFF} = 20\text{ V}$	I_{LKG}	-	1.5	5	μA
Hold/Release current	Active State	$I_{H/R}$	0.1	0.5	1.0	mA
Minimum on current	$V_{ON} < 54\text{ V}$	I_{MIN1}	20	38	-	mA
Minimum on current	$54\text{ V} \leq V_{ON} \leq 100\text{ V}$ for 2 seconds, source resistance $200\ \Omega$ to $4\text{ k}\Omega$	I_{MIN2}	9.0	45	-	mA
Minimum on current	$V_{ON} > 100\text{ V}$	I_{MIN3}	0	0.1	-	mA
Maximum on current	$V_{ON} \leq 70\text{ V}$	I_{MAX1}	-	38.4	70	mA
Maximum on current	$V_{ON} > 70\text{ V}$	I_{MAX2}	-	-	$\frac{V_{ON}}{1\text{ k}\Omega}$	mA
Photodiode drive current	Active State	I_{PD}	0.2	0.3	10	mA

1.4.2 AC Characteristics, Normal Operation

For test conditions: (see Figure 4 on page 6) and (see Figure 5 on page 6).

Parameter	Conditions	Symbol	Minimum	Typical	Maximum	Unit
ac impedance	200 Hz to 50 kHz	Z_{MT}	10	38	-	$\text{k}\Omega$
Linearity distortion	$f = 200\text{ Hz to }40\text{ kHz}$, $I_{SL} = 1\text{ mA to }20\text{ mA}$, $V_{APP} \leq 10.5\text{ V}_{PP}$	D1	75	78	-	dB
Linearity distortion	$f = 200\text{ Hz to }40\text{ kHz}$, $I_{SL} = 1\text{ mA to }20\text{ mA}$, $V_{APP} \leq 12\text{ V}_{PP}$	D2	50	70	-	dB

1.4.3 Transition Characteristics, Normal Operation

For activation/deactivation test conditions: (see Figure 6 on page 7).

Parameter	Conditions	Symbol	Minimum	Typical	Maximum	Unit
Activate time	(see Figure 7 on page 7)	t_1	3.0	13	50	ms
Deactivate time	(see Figure 8 on page 7)	t_2	3.0	-	100	ms

Figure 2. I-V Requirements Template, 0 V to 50 V

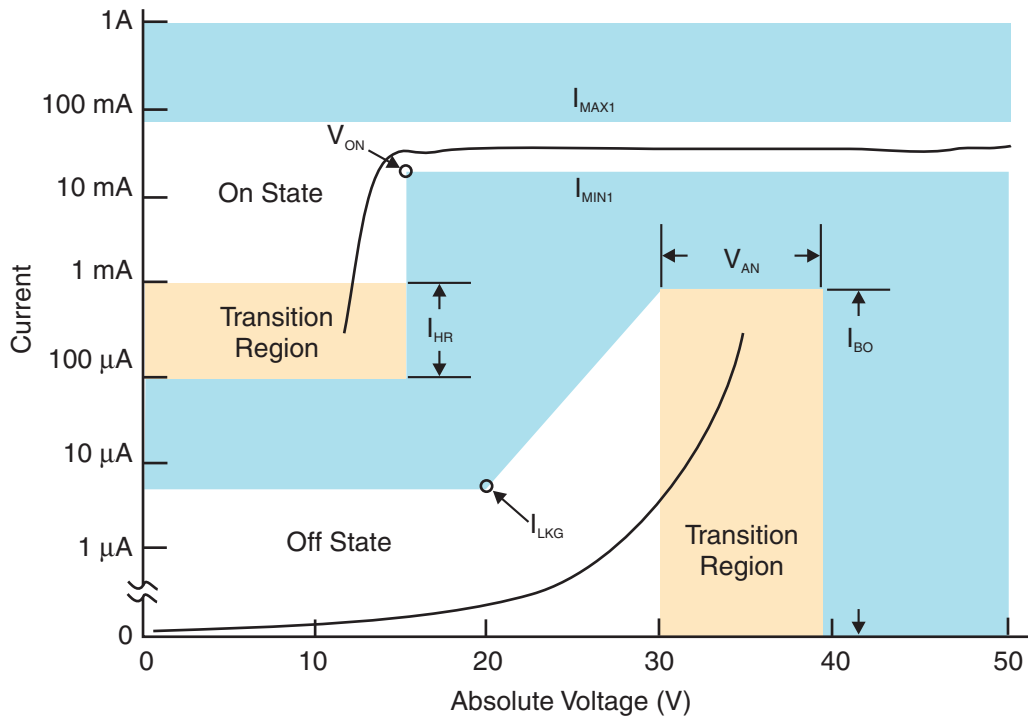

Figure 3. I-V Requirements Template, 0 V to 250 V

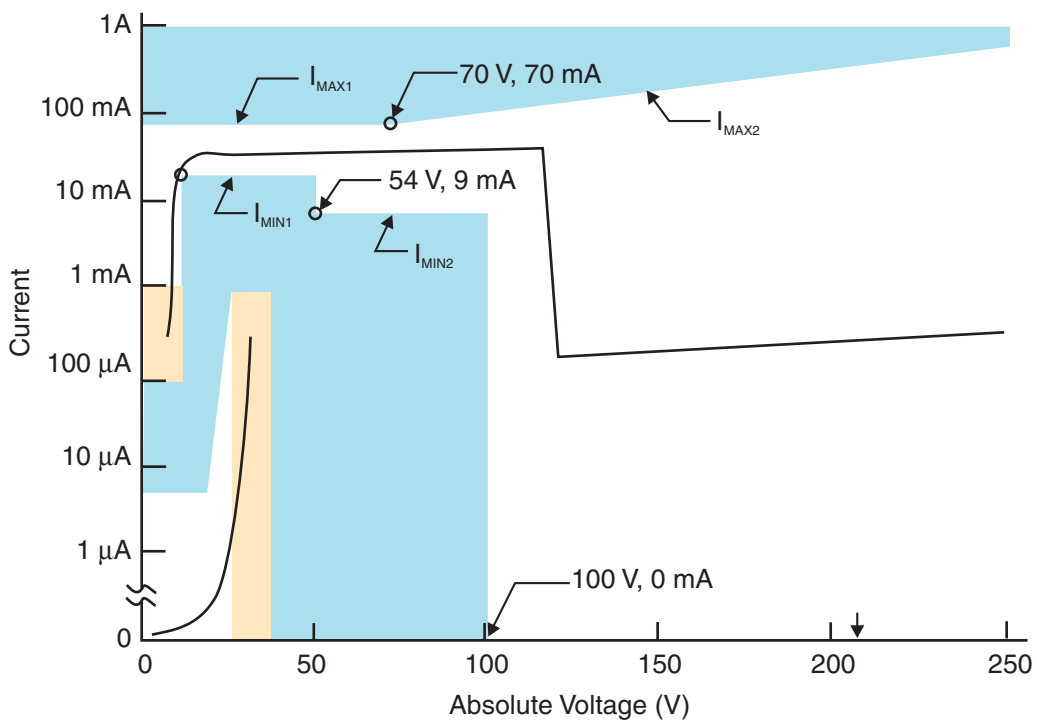
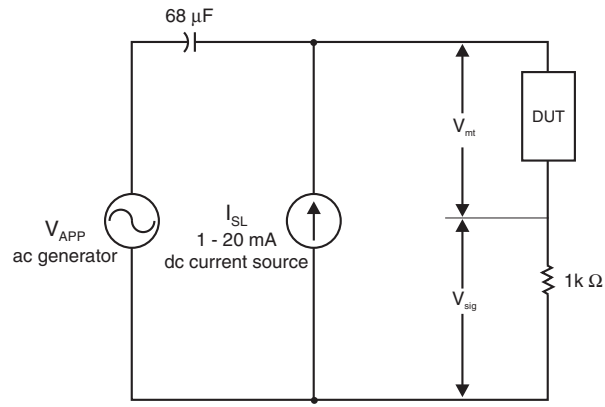

Figure 4. Test Circuit for ac Impedance and Linearity



$$Z_{mt} = \frac{1000 \times V_{mt}}{V_{sig}}$$

$$\text{Linearity} = 20\log\left[\frac{V_{mt}}{V_{sig2ndHarmonic}}\right] + 20\log\left[\frac{1000}{67.5}\right]$$

Figure 5. Linearity Requirement Template

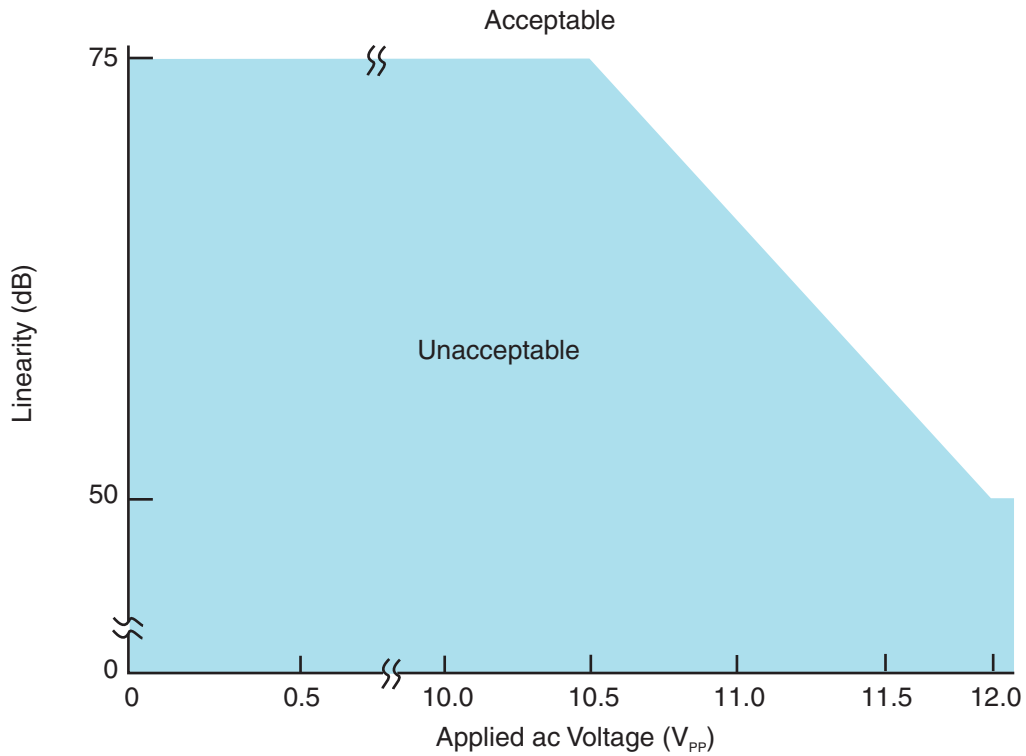

Figure 6. Test Circuit for Activate and Deactivate Times

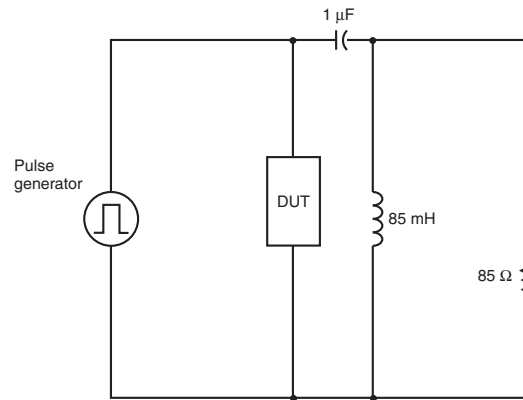

Figure 7. Applied Waveform for Activation Test

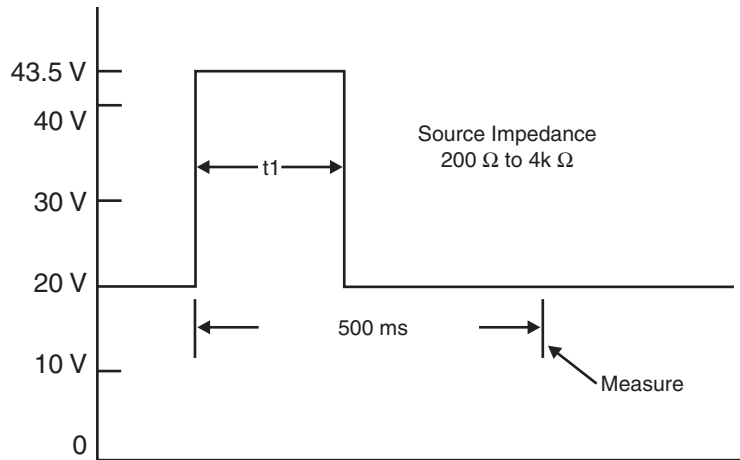
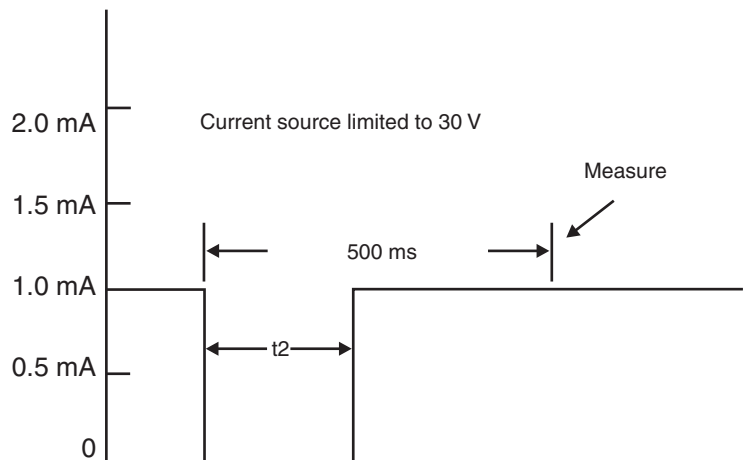

Figure 8. Applied Waveform for Deactivation Test



1.5 Application Signalling Characteristics

These tests assume crowbar protection across the CPC1465 limiting peak potentials to 250 V.

1.5.1 LED Trigger Characteristics During MLT Signalling

For test conditions: (see Figure 9 on page 9).

Parameter	Conditions	Symbol	Minimum	Typical	Maximum	Unit
Applied ac Voltage	-	-	60	-	62	V _{PEAK}
Applied ac frequency	-	-	2	-	3	Hz
Number of half-cycles applied	-	-	6	-	10	-
Total loop resistance	-	-	900	-	4500	Ω
Required opto-coupler response						
Number of pulses per half-cycle applied	-	-	-	1	-	-
Pulse width (opto on)	(see Figure 9 on page 9)	T _{ON}	10	-	-	ms
Pulse width (opto off)	(see Figure 9 on page 9)	T _{OFF}	10	-	-	ms

1.5.2 LED Trigger Characteristics During Dial Test Set Signalling

For test conditions: (see Figure 9 on page 9).

Parameter	Conditions	Symbol	Minimum	Typical	Maximum	Unit
Applied dc battery Voltage	-	-	-43.5	-	-56	V _{DC}
Frequency (pulses per second)	-	-	4	-	8	-
Percent break	-	-	40	-	60	%
Number of pulses	-	-	6	-	10	-
Total Loop Resistance	-	-	200	-	4000	Ω
Required opto-coupler response						
Number of pulses per make/break applied	-	-	-	1	-	-
Pulse width (opto on)	(see Figure 9 on page 9)	T _{ON}	10	-	-	ms
Pulse width (opto off)	(see Figure 9 on page 9)	T _{OFF}	10	-	-	ms

Figure 9. Test Circuit for LED Operation

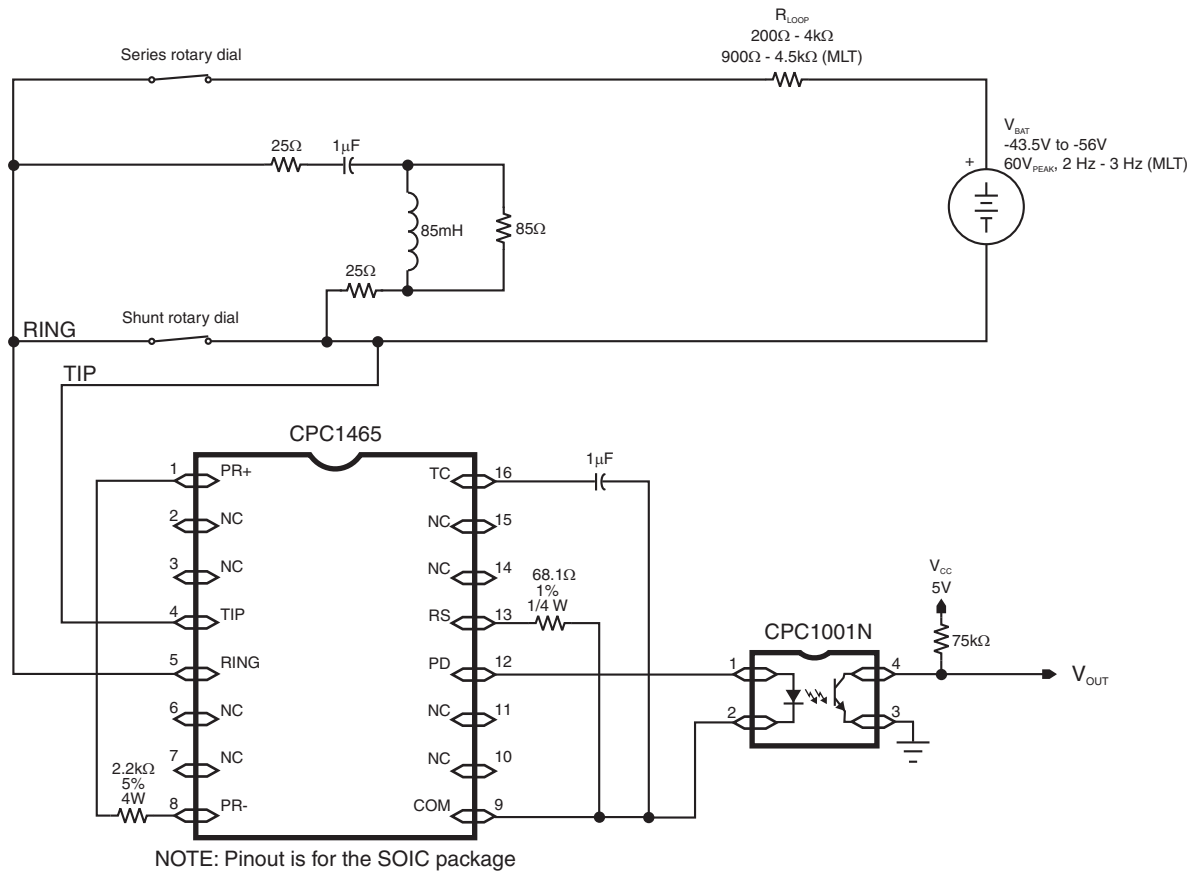
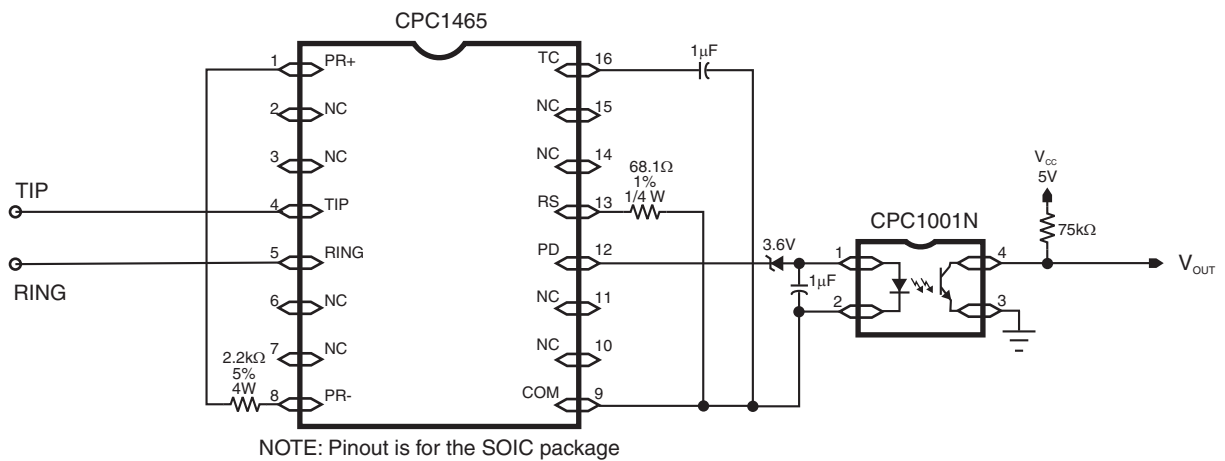

Figure 10. Typical ISDN NT1 Application Diagram



2. Functional Description

2.1 Introduction

The CPC1465 can be used for a number of designs requiring a dc hold circuit such as SHDSL modem and ISDN NT1 terminal applications. Typical SHDSL applications will use a circuit design similar to the one shown in Figure 10, “Typical ISDN NT1 Application Diagram” on page 9 while the typical ISDN NT1 circuit design will be similar to the one shown in Figure 10, “Typical ISDN NT1 Application Diagram” on page 9.

The DC Termination IC performs two functions in an ISDN NT1 terminal; as an electronic inductor providing a low impedance dc termination with a high impedance ac termination, and second as part of the dc signalling system for automated line testing capability. The CPC1465 meets or exceeds the requirements for an NT1 dc termination as described in ANSI T1.601-1991.

Whereas the SHDSL modem application does not have a signalling requirement, the signaling function provides an excellent method to monitor for the loss of sealing current. Generally, loss of sealing current in an SHDSL application indicates loop loss.

As can be seen in the application circuit in Figure 1 on page 1, CPC1465 designs require few external components. For the most basic design, all that is needed is a circuit protector, two resistors and a capacitor.

2.2 Surge Protection

Although the CPC1465 is current limited, it is not an over-voltage surge protector. To protect the CPC1465 against destructive over-voltage transients, Clare recommends the use of a crowbar-type surge protector that limits the surge voltage seen by the CPC1465 to 250 V. The protection device must be able to withstand the surge requirements specified by the appropriate governing agency in regions where the product will be deployed. Teccor, Inc. and Bourns, Inc. make suitable surge protectors for most applications. Devices such as Teccor’s P1800SC or P2000SC Sidactors and Bourns’ TISP4220H3 or TISP4240H3 thyristors should provide suitable protection.

2.3 Bridge Rectifier

The bridge rectifier in the CPC1465 ensures that the device is polarity insensitive and provides consistent

operational characteristics if the tip and ring leads are reversed.

2.4 State Transitions

The dc tip to ring voltage-current characteristics of the CPC1465 are shown in Figure 2, “I-V Requirements Template, 0 V to 50 V”, and in Figure 3, “I-V Requirements Template, 0 V to 250 V” on page 5.

Transition timings are illustrated in Figure 7, “Applied Waveform for Activation Test”, and in Figure 8, “Applied Waveform for Deactivation Test”. The test configuration for these timings is given in Figure 6, “Test Circuit for Activate and Deactivate Times”. All timing figures are located on page 7.

State transition timings are set by the 1 μ F capacitor connected between the TC and COM pins.

2.4.1 Activation - On-State

Application of battery voltage to the loop causes the CPC1465 to conduct whenever the voltage exceeds approximately 35 V. With application of sufficient voltage applied across the tip and ring terminals, the CPC1465 will initially conduct a nominal 150 μ A of sealing current for approximately 20 ms prior to activation. Once activated, the CPC1465 will remain in the on state for as long as the loop current exceeds a nominal 0.5 mA.

The CPC1465 turn-on timing circuit assures device activation will occur within 50 ms of an applied voltage greater than 43.5 V but not within the first 3 ms.

2.4.2 Deactivation - Off-State

While the CPC1465 activation protocol is based on an initial minimum voltage level, deactivation is based on a diminished sealing current level. Deactivation occurs when the nominal sealing current level drops below 0.5 mA with guaranteed deactivation occurring for sealing current levels less than 0.1 mA

The turn-off timing circuit deactivates the sealing current hold circuit when 1 mA of sealing current has been removed for 100 ms but ignores periods of loss up to 3 ms.

2.5 Photo-Diode (PD) Output Behavior

Output from the PD pin provides a minimum of 0.2 mA of photo-diode drive current for the opto-coupler LED anytime sealing current exceeds 1 mA.

Because LED current is interrupted whenever loop current is interrupted, the opto-coupler provides an excellent means of indicating loop availability for designs with a sealing current requirement.

2.6 On-State Behavior

2.6.1 Typical Conditions

On-state sealing current levels are determined by the network's power feed circuit and the loop's dc impedance. To compensate for low loop resistance or very high loop voltage, the CPC1465 limits the maximum sealing current to 70 mA.

The CPC1465 manages package power dissipation by shunting excess sealing current through the 2.2 k Ω 4W power resistor located between the PR+ and PR- pins.

2.6.2 Over-Voltage Conditions

Potentials in excess of 100 V applied to the tip and ring interface will cause the CPC1465 to disable the sealing current hold circuit and enter a standby state with very little current draw. Once the over-voltage condition is removed, the CPC1465 automatically resumes normal operation.

3. Manufacturing Information

3.1 Mechanical Dimensions

3.1.1 SOIC

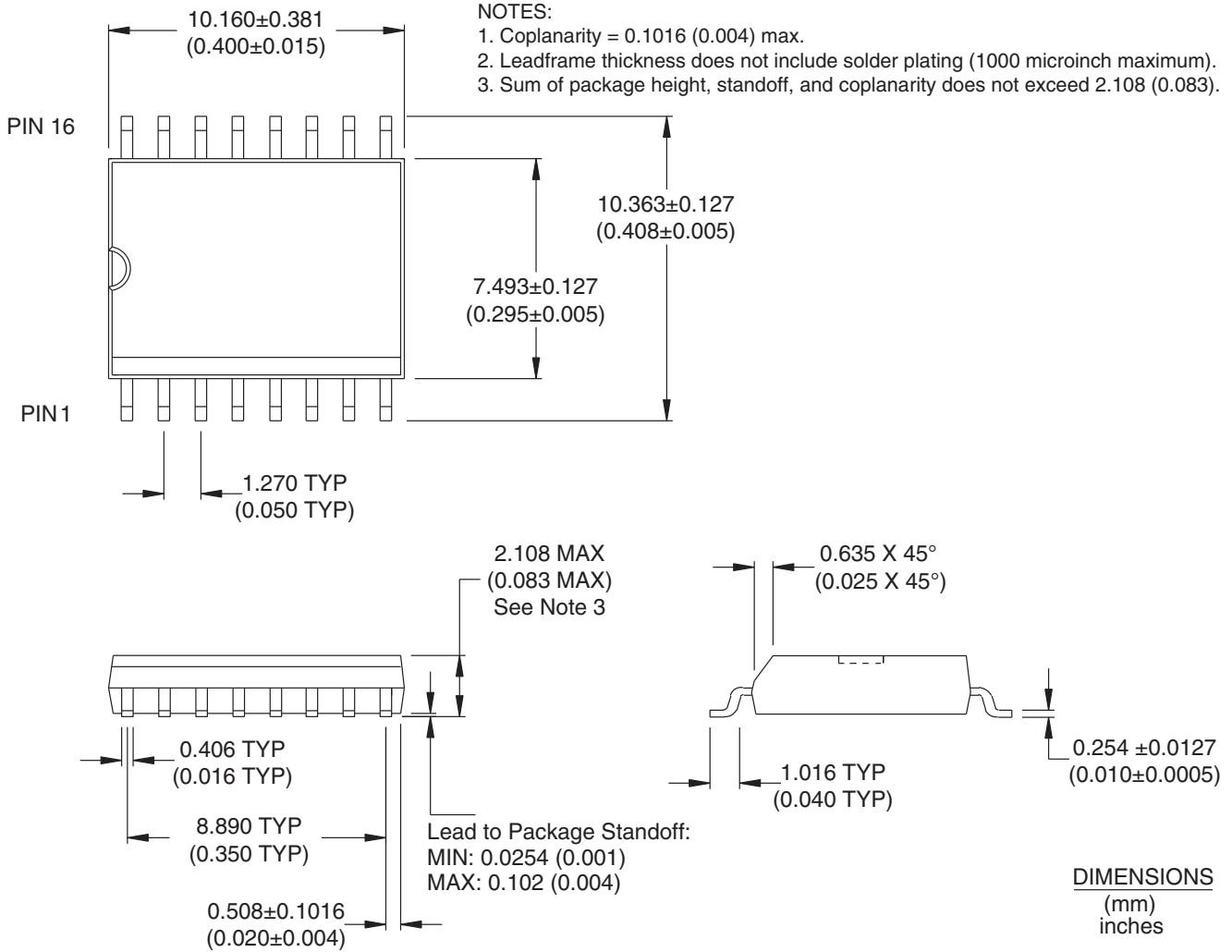

NOTE: The CPC1465 uses a slightly different package than the LH1465AAE. Some adjustment to the printed-circuit-board pad layout may be needed for existing applications.

3.1.2 DFN

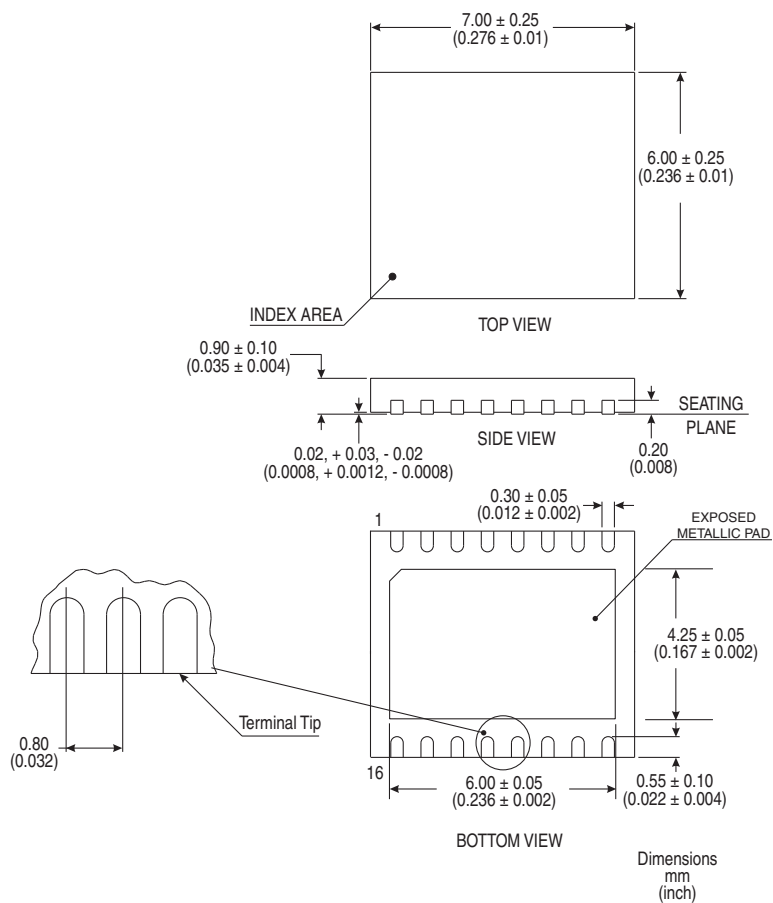

3.3.2 DFN

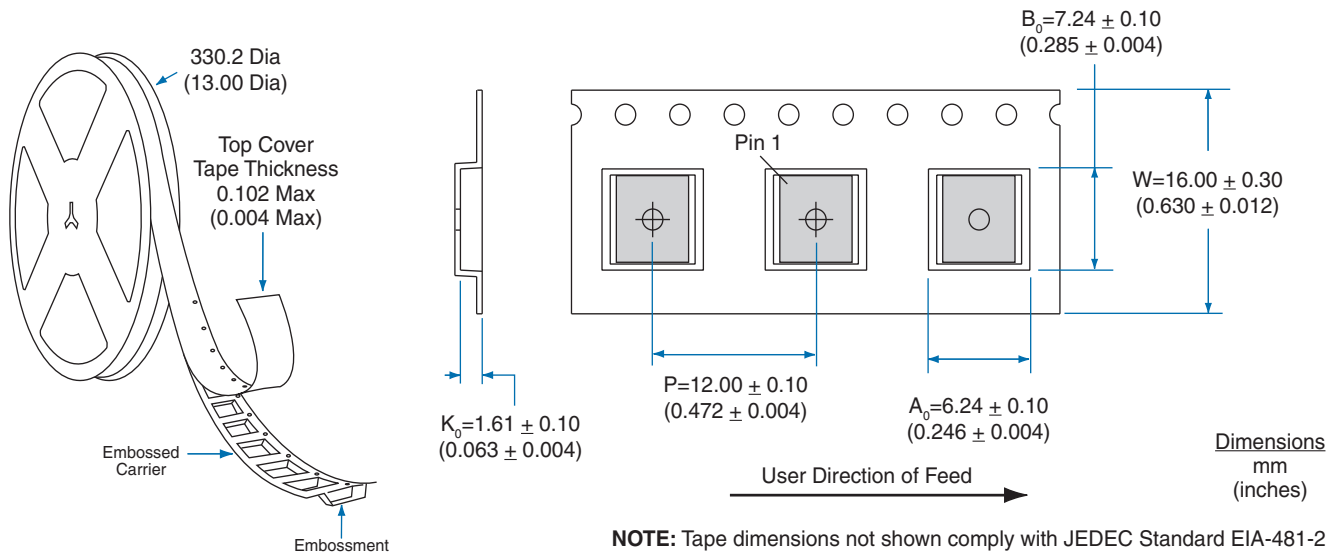

3.4 Soldering

3.4.1 Moisture Reflow Sensitivity

Clare has characterized the moisture reflow sensitivity for this product using IPC/JEDEC standard J-STD-020. Moisture uptake from atmospheric humidity occurs by diffusion. During the solder reflow process, in which the component is attached to the PCB, the whole body of the component is exposed to high process temperatures. The combination of moisture uptake and high reflow soldering temperatures may lead to moisture induced delamination and cracking of the component. To prevent this, this component must be handled in accordance with IPC/JEDEC standard J-STD-033 per the labeled moisture sensitivity level (MSL), level 1 for the SOIC package, and level 3 for the DFN package.

3.4.2 Reflow Profile

For proper assembly, this component must be processed in accordance with the current revision of IPC/JEDEC standard J-STD-020. Failure to follow the recommended guidelines may cause permanent damage to the device resulting in impaired performance and/or a reduced lifetime expectancy.

3.5 Washing

Clare does not recommend ultrasonic cleaning of this part.



For additional information please visit www.clare.com

Clare, Inc. makes no representations or warranties with respect to the accuracy or completeness of the contents of this publication and reserves the right to make changes to specifications and product descriptions at any time without notice. Neither circuit patent licenses or indemnity are expressed or implied. Except as set forth in Clare's Standard Terms and Conditions of Sale, Clare, Inc. assumes no liability whatsoever, and disclaims any express or implied warranty relating to its products, including, but not limited to, the implied warranty of merchantability, fitness for a particular purpose, or infringement of any intellectual property right.

The products described in this document are not designed, intended, authorized, or warranted for use as components in systems intended for surgical implant into the body, or in other applications intended to support or sustain life, or where malfunction of Clare's product may result in direct physical harm, injury, or death to a person or severe property or environmental damage. Clare, Inc. reserves the right to discontinue or make changes to its products at any time without notice.

Specifications: DS-CPC1465 - R02
© Copyright 2008, Clare, Inc.
All rights reserved. Printed in USA.
4/16/08