

HY404XX01

40 CHAR X 4 LINE

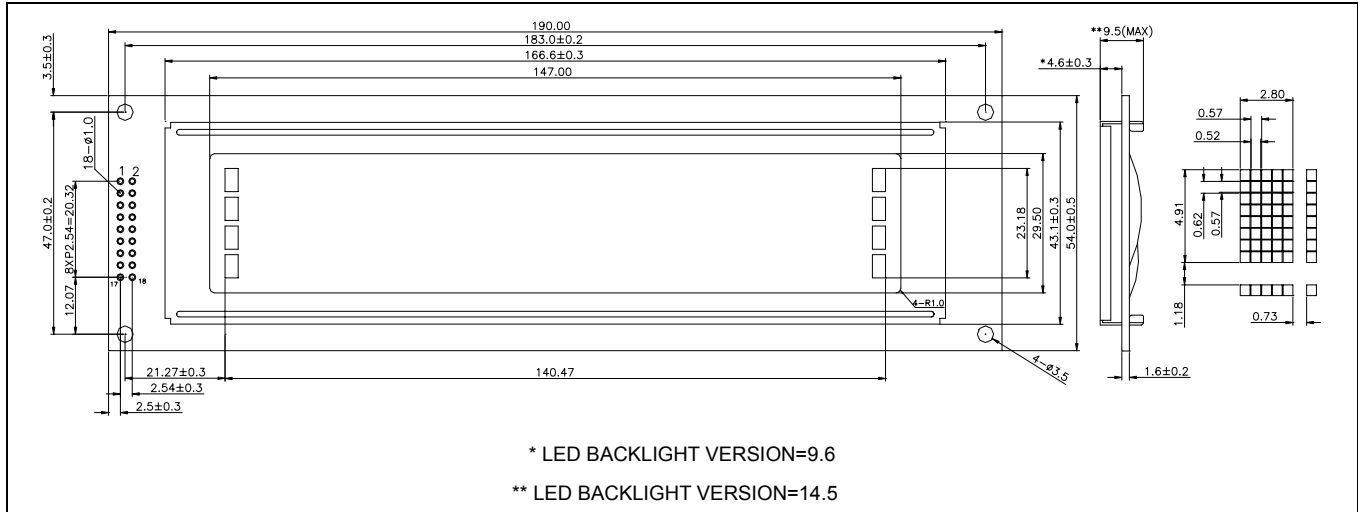

2. MECHANICAL DATA

ITEM	SPECIFICATION	UNIT
Module Size (W×H×T)	190.0×54.0×9.5 (LED:14.5)	mm
Viewing Area (W×H)	147.0×29.5	mm
Character Font (W×H)	5×7 with Cursor	dots
Character Size (W×H)	2.8×4.91	mm
Character Pitch (W×H)	3.53×6.09	mm
Dot Size (W×H)	0.52×0.57	mm

5. ABSOLUTE MAXIMUM RATINGS

PARAMETER	SYMBOL	MIN.	MAX.	UNIT
Supply Voltage (Logic)	$V_{DD} - V_{SS}$	-0.3	7.0	V
Supply Voltage (Driver)	V_O	$V_{DD} - 12$	$V_{DD} + 0.3$	V
Input Voltage	V_{IN}	-0.3	$V_{DD} + 0.3$	V

3. PIN CONFIGURATION

PIN	SYMBOL	SIGNAL DESCRIPTION
1 ~ 8	DB ₀ to DB ₇	Data Bus-Software Selectable 4 or 8bit Mode
9	E1	Enable R/W= Low : Data are talking over at falling edge R/W=High : Data can be read
15	E2	Read/Write Low = MPU to LCM, High = LCM to MPU
10	R/W	Register Select Low = Instruction, High = Data
11	RS	Supply Voltage LCD Driving
12	Vo	GND (0V)
13	V _{SS}	Power Supply
14	V _{DD}	No Connection
16	N/C	Anode of LED Unit
17	A	Cathode of LED Unit
18	K	

6. ELECTRICAL CHARACTERISTICS (Ta=25 °C)

ITEM	SYMBOL	CONDITION	SPEC. VALUE			UNIT
			MIN.	TYP.	MAX.	
Supply Voltage (Logic)	$V_{DD} - V_{SS}$		4.5	5.0	5.5	V
Supply Current (Logic)	I_{DD}	$V_{DD}=5V$	-	0.8	2.0	mA
Input Voltage	"HIGH"	V_{IH}	-	2.2	-	V_{DD}
	"LOW"	V_{IL}	-	-0.3	-	0.6
Output Voltage	"HIGH"	V_{OH}	$-I_{OH}=0.2mA$	2.4	-	V
	"LOW"	V_{OL}	$I_{OL}=1.2mA$	-	-	0.4
LCD Operating Voltage	$V_{DD} - V_O$	$V_{DD}=5V, Ta=25 °C$	4.2	4.4 (7.8)	4.6	v
Supply Voltage LCD Drive	I_o		-	1.0	1.5	mA

Note : () Value is high Reliability type

4. BLOCK DIAGRAM

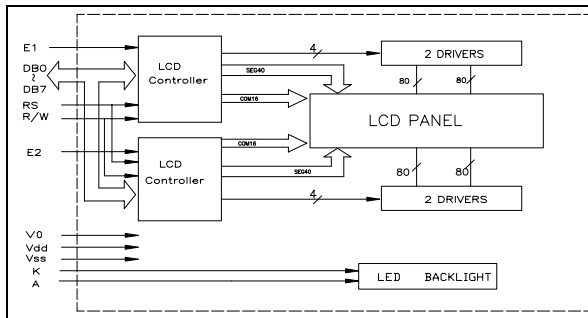

7. BACKLIGHTING CHARACTERISTICS (Ta=25 °C)

LED

ITEM	SYMBOL	CONDITION	MIN.	TYP.	MAX.	UNIT
Supply Voltage	V_{LED}	-	-	4.1	-	V
Power Consumption	P_{LED}	$I_F=500mA$	-	1000	-	mW
Luminous	I_V	$I_F=500mA$	-	80	-	cd/m ²