

# 11-FD212

---

*Version* : A.003  
*Issue Date* : 2007/01/08  
*File Name* : SP-11FD212-A.003.doc  
*Total Pages*: 8

*Single Coil Brushless  
DC Motor Drivers Built-in Hall Sensor  
( 2 to 5.5 Volts )*



新竹市展業一路9號7樓之1

SILICON TOUCH TECHNOLOGY INC.

9-7F-1, Prosperity Rd 1, Science-Based Industrial Park  
Hsinchu, Taiwan, R.O.C.

Tel : 886-3-5645656 Fax : 886-3-5645626

## 11-FD212

### Single Coil Brushless DC

### Motor Drivers Built-in Hall Sensor ( 2 to 5.5 Volts)

#### General Specifications

The device is designed specifically for electronic commutation of single coil DC motor applications. Each device includes a HALL sensor, a frequency generator output, a lock detection circuit to shut down the drivers for overheat prevention, and complementary bi-directional drivers for driving and sinking large load on a single silicon chip.

If the motor rotation is stalled by external force or obstacles, overdrive current ( or lock current ) may incur coil overheat/burning. To prevent coil overheat/burning, these devices incorporate lock detection circuit to shut down the drivers. After the motor locking is released, the drivers can be powered up using an automatic self-restart circuit. The drivers are shut down roughly 1 to 3 seconds after the motor is locked. After the drivers are shut down, the automatic self-restart circuit will try to power up the drivers every 1 to 3 seconds.

## Pin Description

(LFCSP8)

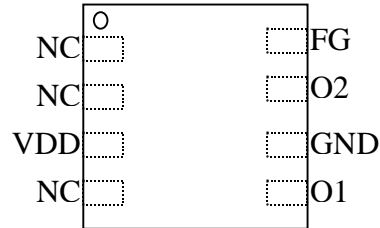

PIN NO.	PIN NAME	DESCRIPTION	PIN NO.	PIN NAME	DESCRIPTION
1	NC	No connection	5	O1	Output driving/sinking pin 1
2	NC	No connection	6	GND	Ground pin
3	VDD	Power supply pin	7	O2	Output driving/sinking pin 2
4	NC	No connection	8	FG	Frequency generator output

(SOT-25)

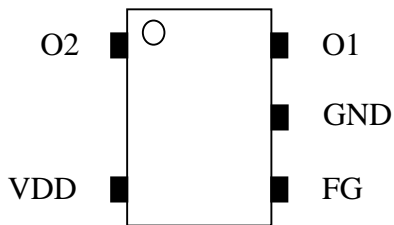

PIN NO.	PIN NAME	DESCRIPTION
1	O2	Output driving/sinking pin 2
2	VDD	Power supply pin
3	FG	Frequency generator output
4	GND	Ground pin
5	O1	Output driving/sinking pin 1

## Features and Benefits

- Optimized for single coil Brushless DC Motor applications
- Built-in Hall effect sensor
- Built-in Reverse Protection
- Frequency generator output
- Lock detection and automatic self-restart without external capacitor
- High output sinking and driving capability
- Ultra-thin, small and highly reliable package (LFCSP8,SOT-25)

### Absolute Maximum Ratings ( Unless otherwise noted, $T_A = 25^\circ\text{C}$ )

Characteristic	Symbol	Rating	Unit
Supply Voltage	$V_{DD}$	6.5	V
Input Voltage from a Hall Effect Latch Output	$V_{IN}$	$V_{DD}+0.4$	V
Output Current	$I_{OUT}$	350	mA
Maximum Power Dissipation of LFCSP8	$P_{D1,max}$	600	mW
Thermal Resistance LFCSP8	$\theta_{JA1}$	208.5	$^\circ\text{C}/\text{W}$
Maximum Power Dissipation of SOT25	$P_{D2,max}$	360	mW
Thermal Resistance SOT25	$\theta_{JA2}$	347	$^\circ\text{C}/\text{W}$
Operating Temperature Range	$T_{OPR}$	-40 ~ 125	$^\circ\text{C}$
Storage Temperature Range	$T_{STG}$	-65 ~ 150	$^\circ\text{C}$

### Electrical Characteristics ( $T_A = 25^\circ\text{C}$ )

Characteristic	Sym.	Condition	Limit			Unit
			Min.	Typ.	Max.	
Supply Voltage	$V_{DD}$	Operating	2	3.3	5.5	V
Supply Current	$I_{DD}$	Auto-restart operating		5	10	mA
Magnetic Specifications ( $T_J = 25^\circ\text{C}$ )						
Operating Point	$B_{OP}$		-	1.0	10	mT
Release Point	$B_{RP}$		-	-1.0	-10	mT
Hysteresis	$B_{HYS}$		-	2.0	20	mT
O1/O2 Output Terminal ( $T_J = 25^\circ\text{C}$ )						
Output Voltage High	$V_{OH}$	$I_{OUT} = 300\text{ mA}$	4.7	-	-	V
Output Voltage Low	$V_{OL}$	$I_{OUT} = 300\text{ mA}$	-	-	0.3	V
Output Current	$I_{OUT}$	$R_L = 30\ \Omega$	-	148	-	mA
FG Open-Drain Terminal ( $T_J = 25^\circ\text{C}$ )						
Output Leakage Current	$I_{FGLK}$	$V_{FG} = 5\text{ V}$			5	$\mu\text{A}$
Output Voltage Low	$V_{FGOL}$	$I_{FG} = 10\text{ mA}$			0.4	V
Automatic Self-Restart Circuit						
On Time	$T_{ON}$	-	-	152	-	ms
Duty Ratio	$R_{DR}$	$T_{OFF} / T_{ON}$	6	7	8	

## Block Diagram & Application Circuit

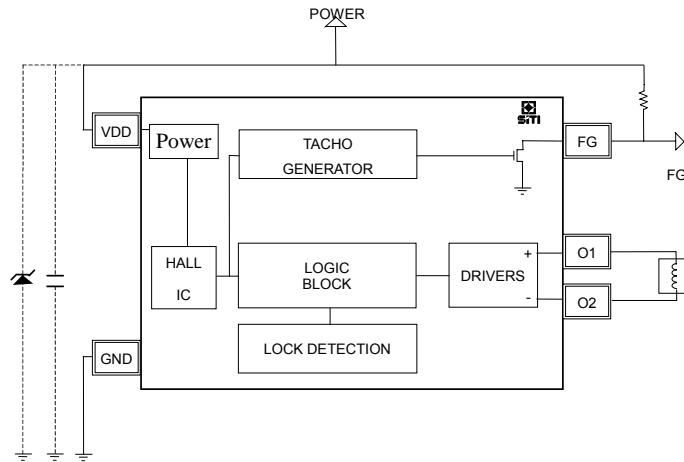

## Application Notes

- There is no requirement of the bypass capacitor or Zener Diode between VDD and GND in normal applications. The connection of this capacitor or Zener Diode will increase stability of operation, if required.
- The **FG** pin is an open-drained output. The output frequency is corresponding to the rotation speed sensed by the built-in Hall effect position sensor. With suitable output pull-up, the fan tachometer output can be used directly with bipolar or MOS logic for motor speed monitoring/control.
- The power dissipated by the IC varies widely with the supply voltage, the output current, and loading. It is important to ensure the application does not exceed the allowable power dissipation of the IC package. The recommended *motor driver* power dissipation versus temperature of SOT25 and LFCSP8 are depicted as follows:

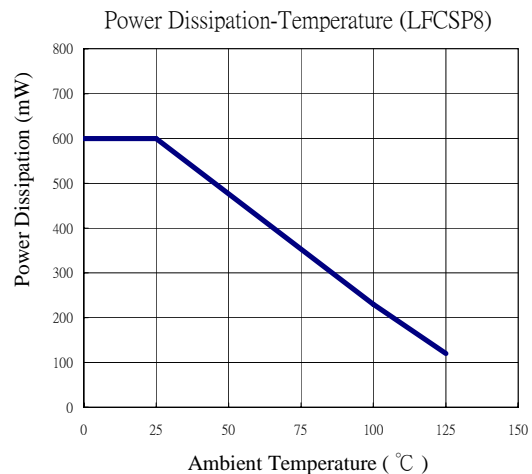
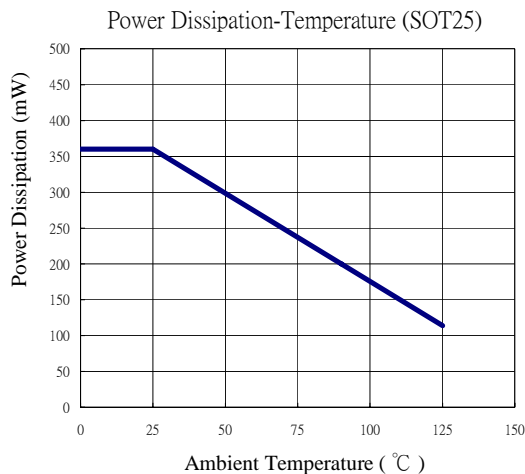

**Electrical Characteristic (T<sub>A</sub>= 25°C)**

⊙The BOP versus supply voltage curve.

⊙The BRP versus supply voltage curve.

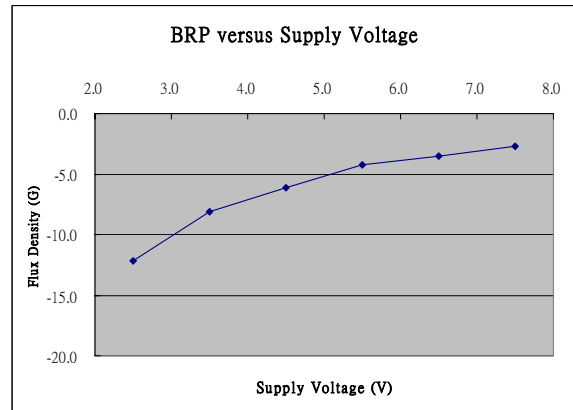
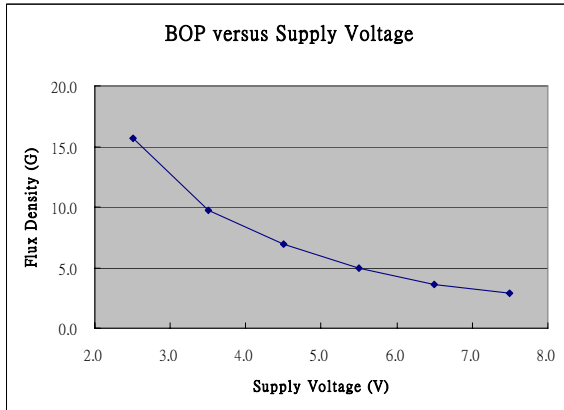

⊙The Hysteresis versus supply voltage curve.

⊙The saturation voltage of output.

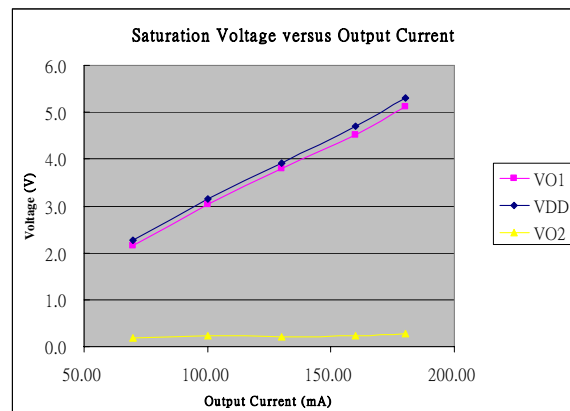
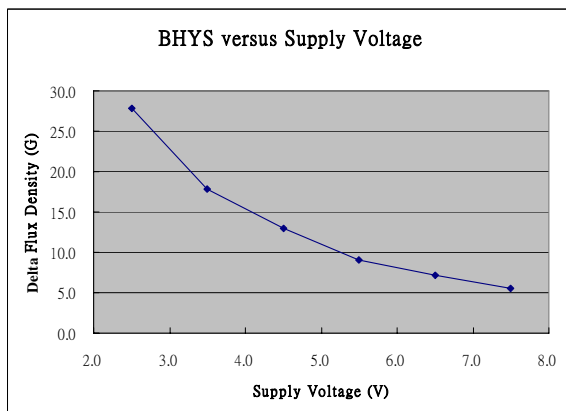

## Package Specifications (LFCSP8)

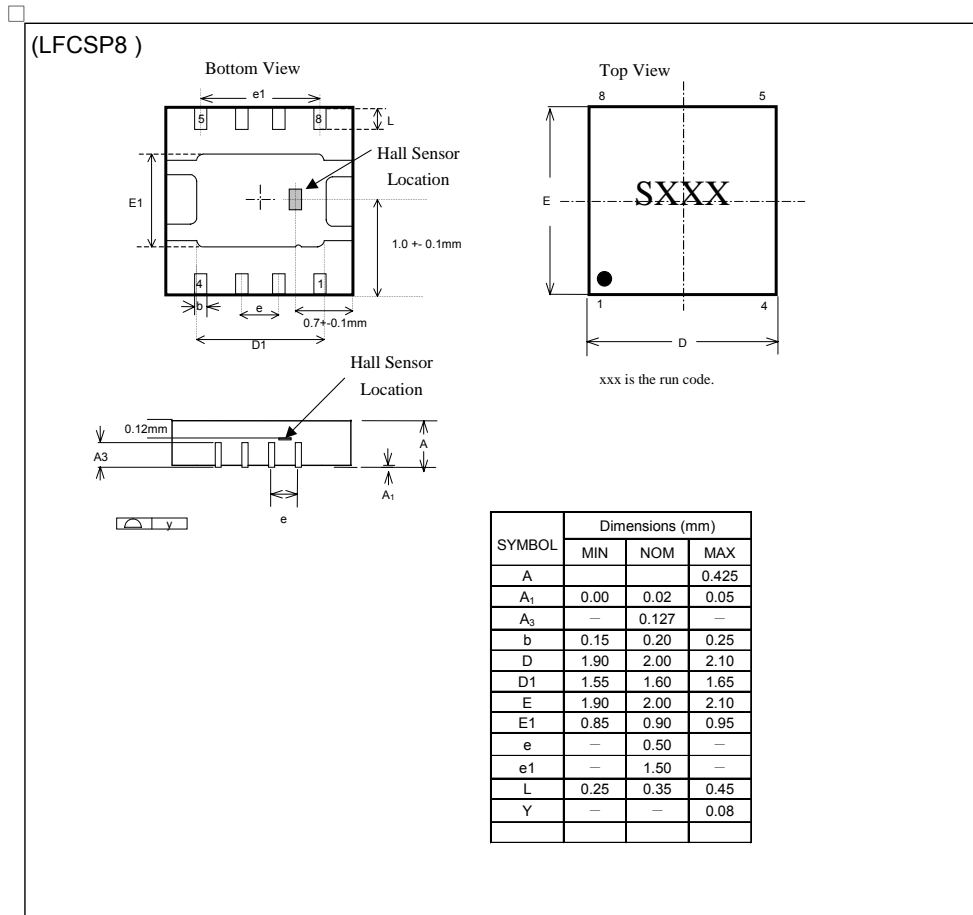

( SOT-25 )

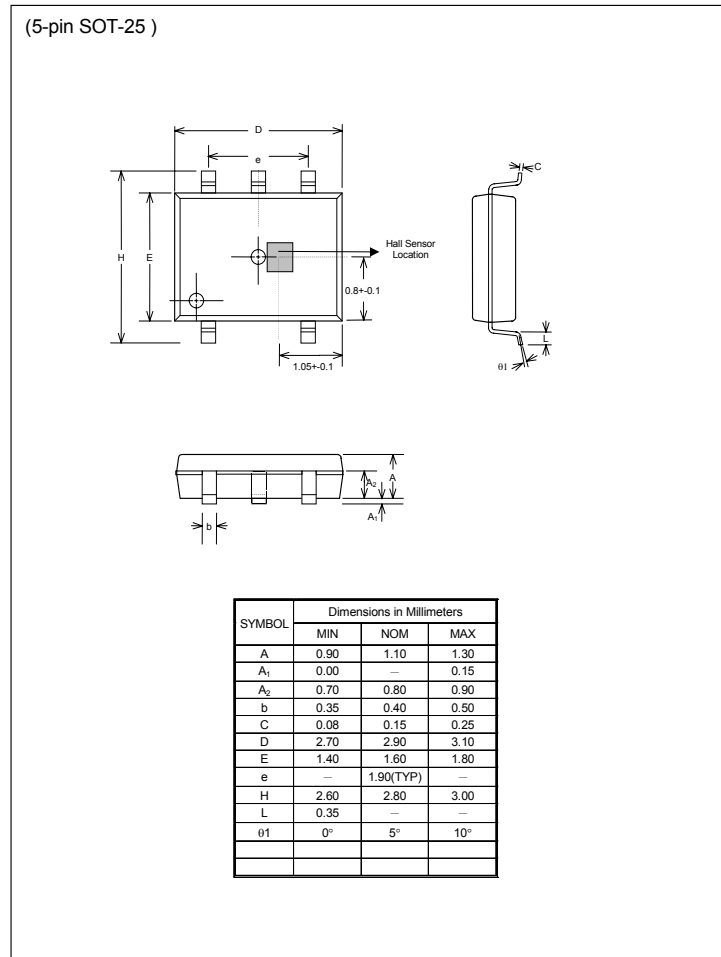

The products listed herein are designed for ordinary electronic applications, such as electrical appliances, audio-visual equipment, communications devices and so on. Hence, it is advisable that the devices should not be used in medical instruments, surgical implants, aerospace machinery, nuclear power control systems, disaster/crime-prevention equipment and the like. Misusing those products may directly or indirectly endanger human life, or cause injury and property loss.

Silicon Touch Technology, Inc. will not take any responsibilities regarding the misuse of the products mentioned above. Anyone who purchases any products described herein with the above-mentioned intention or with such misused applications should accept full responsibility and indemnify. Silicon Touch Technology, Inc. and its distributors and all their officers and employees shall defend jointly and severally against any and all claims and litigation and all damages, cost and expenses associated with such intention and manipulation.