

759-840 Adapter to Adapter Factory Terminated Conduit Assembly

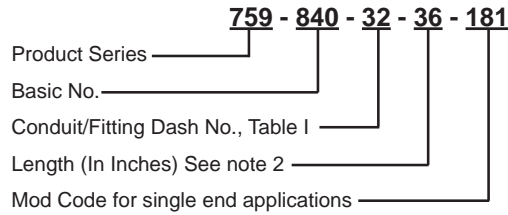

NOTE: -181 mod code is used to create single-ended conduit assemblies. One end is terminated with a solder fitting for the attachment of MIL-PRF 24758A adapters, while the other end is left unfinished for use with user installable fittings.

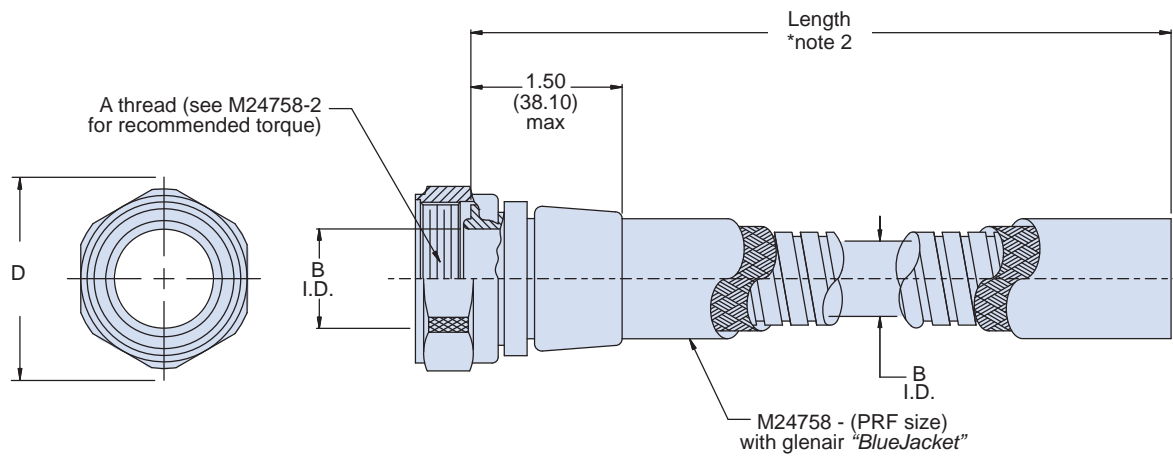

APPLICATION NOTES

1. Assembly identified with manufacturer's code identification number (Glenair, part number and classification code 490).
2. Length tolerance is 0-24" = $\pm 1/4$ ", for longer lengths is $\pm 1\%$ of length.
3. Glenair 600 series backshell assembly tools are recommended for assembly installation.
4. Material / Finish:
Adapter, ferrule & coupling nut, AISI 316 stainless steel / electroless nickel, matte finish.
5. Metric dimensions (mm) are indicated in parentheses.

759-840
Single Ended Adapter Fitting Assembly
Factory Terminated Conduit Assembly



MIL-PRF
 24758A

TABLE I			
DASH NO	MIL PRF SIZE	B MIN.	C THREAD CLASS 2B
08	A	0.245 (6.22)	.438-28 UNEF
12	J	0.370 (9.40)	.563-24 UNEF
16	B	0.495 (12.57)	.688-24 UNEF
20	K	0.620 (15.75)	.813-20 UNEF
24	C	0.745 (18.92)	.938-20 UNEF
32	D	0.995 (25.27)	1.250-18 UNEF
40	E	1.245 (31.62)	1.563-18 UNEF
48	F	1.495 (37.97)	1.875-16 UN
64	G	1.995 (50.67)	2.375-16 UN
80	H	2.495 (63.37)	2.875-16 UN
96	L	2.995 (76.07)	3.375-16 UN