



### Approvals

GAM T1 LISTED

### Life expectancy

L-10 LIFE AT 40°C:  
25 000 hours

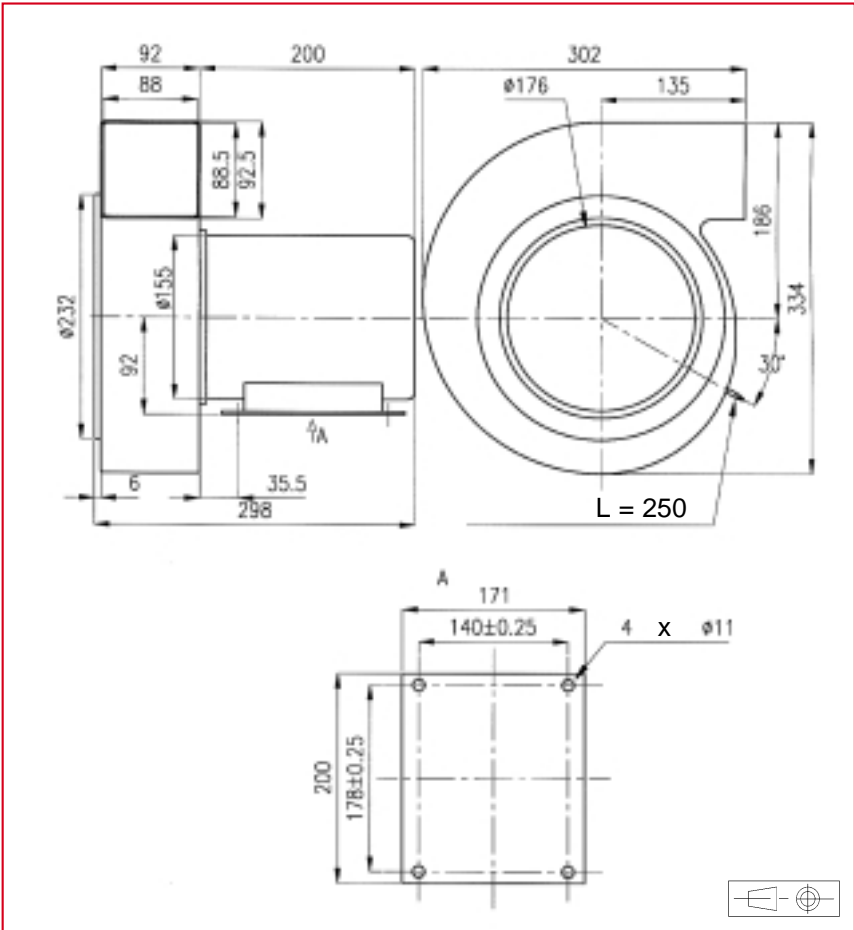
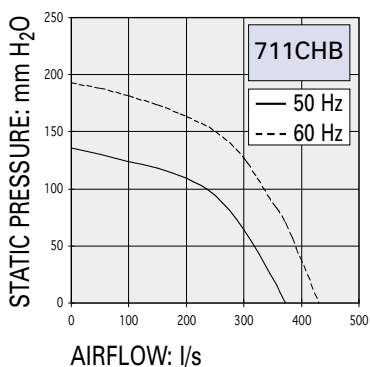

**AC Motor**  
 Housing material: aluminium  
 Wheel material: aluminium  
 Weight: 19 kg  
 Bearing system: ball bearings

Connection: flying leads

**Available with:**  
 - safety switch

Part number	Nominal voltage	Airflow	Noise level	Nominal speed	Frequency	Phases	Capacitor	Input power	Nominal current	Starting current	Operating temperature	
	V	l/s	dB(A)	RPM	Hz		$\mu F$	W	mA	mA	Min. °C	Max. °C
711CHB016DC13	220	370	79	2850	50	3		1000	3000	17000	- 10	70
	380	370	79	2850	50	3		1000	1750	10000	- 10	70
	220	420	82	3200	60	3		1550	4300	16000	- 10	70
	380	420	82	3200	60	3		1550	2500	9500	- 10	70

### Additional versions:

Other voltage - salt spray protected - shock and vibration protected - marine specifications - wide temperature range