

Linear MOSFET Power Module

$$V_{DSS} = 600V$$

$$R_{DSon} = 125m\Omega \text{ typ @ } T_j = 25^\circ C$$

$$I_D = 45A^* @ T_c = 25^\circ C$$

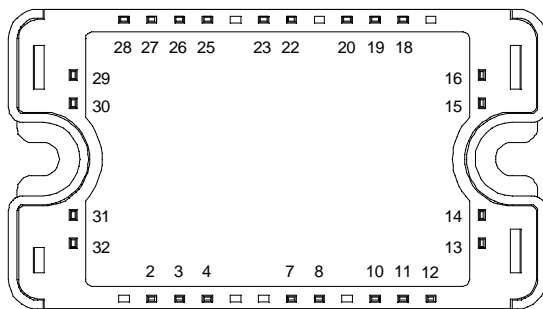
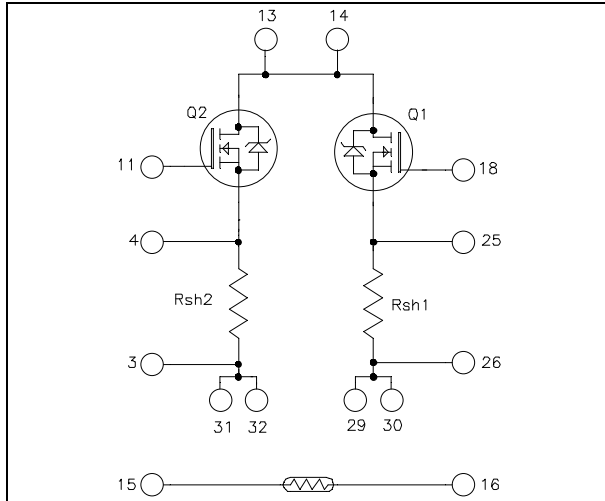

Pins 13/14 ; 29/30 ; 31/32 must be shorted together

Application

- Electronic load dedicated to power supplies and battery discharge testing

Features

- Linear MOSFET
- Very low stray inductance
- Internal thermistor for temperature monitoring
- High level of integration
- AIN substrate for improved thermal performance

Benefits

- Direct mounting to heatsink (isolated package)
- easy series and parallels combinations for power and voltage improvements
- Low junction to case thermal resistance
- Solderable terminals both for power and signal for easy PCB mounting
- Low profile
- RoHS Compliant

Absolute maximum ratings (per leg)

Symbol	Parameter	Max ratings	Unit
V_{DSS}	Drain - Source Breakdown Voltage	600	V
I_D	Continuous Drain Current	$T_c = 25^\circ C$	45*
		$T_c = 80^\circ C$	33*
I_{DM}	Pulsed Drain current	172	A
V_{GS}	Gate - Source Voltage	± 30	V
R_{DSon}	Drain - Source ON Resistance	130	m Ω
P_D	Maximum Power Dissipation 1	$T_c = 25^\circ C$	568
I_{AR}	Avalanche current (repetitive and non repetitive)	45	A
E_{AR}	Repetitive Avalanche Energy	50	mJ
E_{AS}	Single Pulse Avalanche Energy	3000	

* Output current must be limited to 31A @ $T_c=25^\circ C$ and 22A @ $T_c=80^\circ C$ to not exceed the shunt specification.

1 In saturation mode

CAUTION: These Devices are sensitive to Electrostatic Discharge. Proper Handling Procedures Should Be Followed. See application note APT0502 on www.microsemi.com



All ratings @ $T_j = 25^\circ\text{C}$ unless otherwise specified

Electrical Characteristics (per leg)

Symbol	Characteristic	Test Conditions	Min	Typ	Max	Unit
I_{DSS}	Zero Gate Voltage Drain Current	$V_{DS} = 600\text{V}; V_{GS} = 0\text{V}$			25	μA
		$T_j = 25^\circ\text{C}$				
$R_{DS(on)}$	Drain – Source on Resistance	$V_{GS} = 10\text{V}, I_D = 22.5\text{A}$		125	130	$\text{m}\Omega$
		$T_j = 125^\circ\text{C}$				
$V_{GS(th)}$	Gate Threshold Voltage	$V_{GS} = V_{DS}, I_D = 2.5\text{mA}$	2		4	V
I_{GSS}	Gate – Source Leakage Current	$V_{GS} = \pm 30\text{V}$			± 100	nA

Dynamic Characteristics (per leg)

Symbol	Characteristic	Test Conditions	Min	Typ	Max	Unit
C_{iss}	Input Capacitance	$V_{GS} = 0\text{V}$		7600		pF
C_{oss}	Output Capacitance	$V_{DS} = 25\text{V}$		1280		
C_{rss}	Reverse Transfer Capacitance	$f = 1\text{MHz}$		620		

Shunt Electrical Characteristics (per leg)

Symbol	Characteristic	Min	Typ	Max	Unit
R_{sh}	Resistance value		20		$\text{m}\Omega$
T_{sh}	Tolerance		2		%
P_{sh}	Load capacity	$T_C = 25^\circ\text{C}$		20	W
		$T_C = 80^\circ\text{C}$		10	
I_{sh}	Current capacity	$T_C = 25^\circ\text{C}$		31	A
		$T_C = 80^\circ\text{C}$		22	

Temperature sensor PTC

Symbol	Characteristic	Min	Typ	Max	Unit
R_{25}	Resistance @ 25°C	1980		2020	Ω
R_{100}/R_{25}	Resistance ratio	$T_{amb} = 100^\circ\text{C} \& 25^\circ\text{C}$	1.676	1.696	1.716
R_{55}/R_{25}	Resistance ratio	$T_{amb} = -55^\circ\text{C} \& 25^\circ\text{C}$	0.48	0.49	0.50
B	Temperature coefficient		7900		ppm/K

Thermal and package characteristics

Symbol	Characteristic	Min	Typ	Max	Unit	
R_{thJC}	Junction to Case Thermal Resistance	MOSFET (per leg)		0.22	$^\circ\text{C}/\text{W}$	
V_{ISOL}	RMS Isolation Voltage, any terminal to case $t = 1\text{min}$, $I_{isol} < 1\text{mA}$, 50/60Hz	4000			V	
T_j	Operating junction temperature range	-40		150	$^\circ\text{C}$	
T_{STG}	Storage Temperature Range	-40		125		
T_C	Operating Case Temperature	-40		100		
Torque	Mounting torque	To heatsink	M4	2.5	4.7	N.m
Wt	Package Weight				110	g

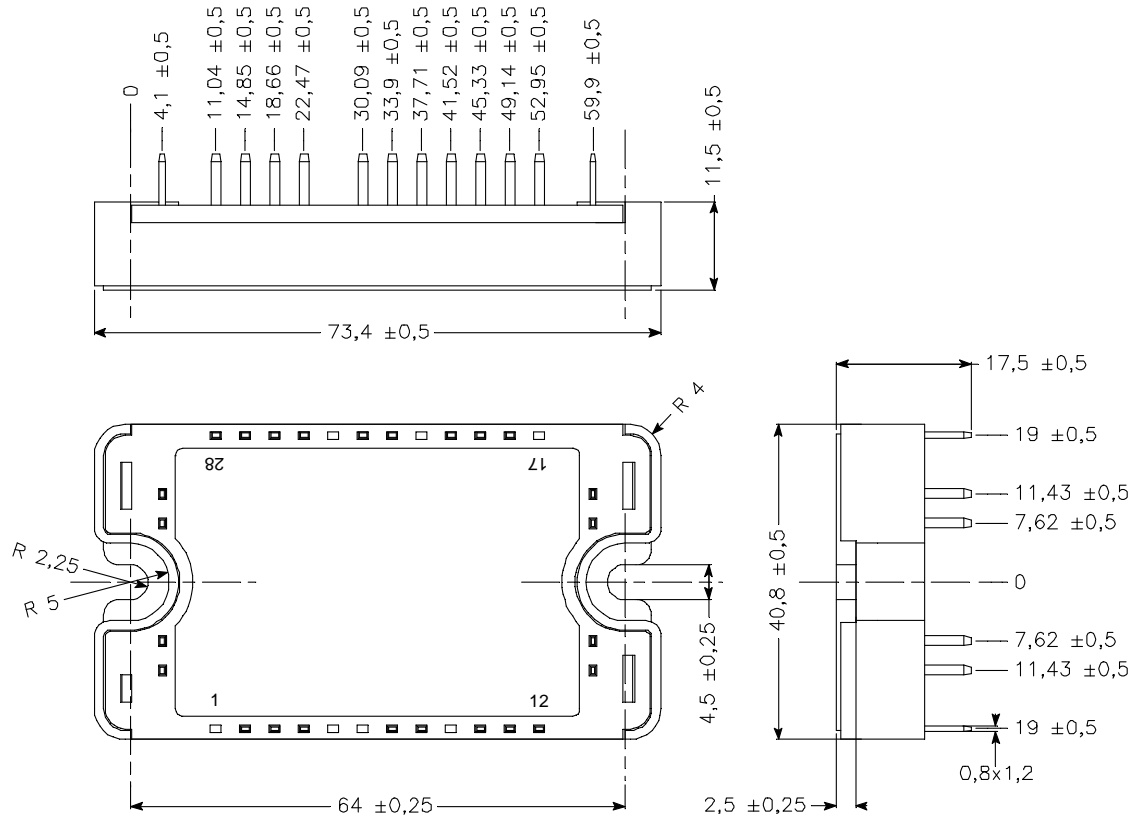
SP3 Package outline (dimensions in mm)

See application note 1901 - Mounting Instructions for SP3 Power Modules on www.microsemi.com

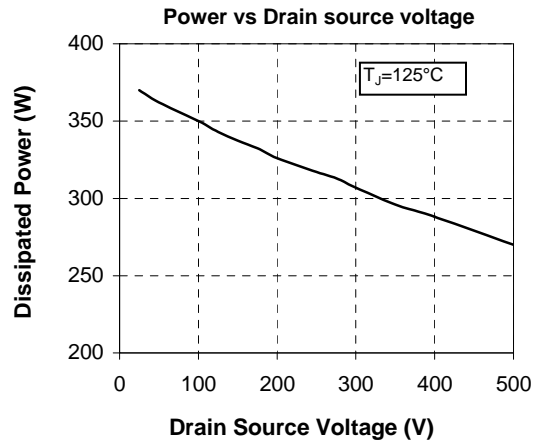
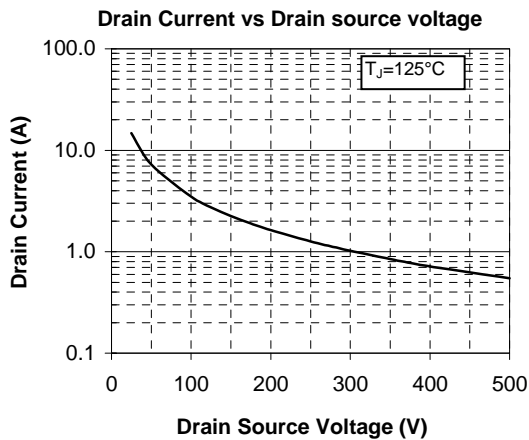
Typical Performance Curve (linear mode) (per leg)

Microsemi reserves the right to change, without notice, the specifications and information contained herein

Microsemi's products are covered by one or more of U.S. patents 4,895,810 5,045,903 5,089,434 5,182,234 5,019,522 5,262,336 6,503,786 5,256,583 4,748,103 5,283,202 5,231,474 5,434,095 5,528,058 6,939,743 7,352,045 5,283,201 5,801,417 5,648,283 7,196,634 6,664,594 7,157,886 6,939,743 7,342,262 and foreign patents. U.S and Foreign patents pending. All Rights Reserved.