

## Low Profile Fast Infrared Transceiver (FIR, 4 Mbit/s) for IrDA® Applications



### Description

The TFBS6711 is the smallest FIR transceiver available. It is a low profile and low-power IrDA transceiver. Compliant to IrDA's Physical Layer specification, the TFBS6711 supports data transmission rates from 9.6 kbit/s to 4 Mbit/s with a typical link distance of 50 cm. It also enables mobile phones and PDAs to function as universal remote controls for televisions, DVDs and other home appliances. The TFBS6711 emitter covers a range of 6.5 meters with common remote control receivers. Integrated within the transceiver module is a PIN photodiode, an infrared emitter, and a low-power control IC. The TFBS6711 can be completely shutdown, achieving very low power consumption. The TFBS6711 has an I/O voltage



related to the supply voltage while TFBS6712 supports low voltage logic of 1.8 V allowing direct connection to a microcontroller's I/Os operating at 1.8 V.

### Features

- Lowest profile: 1.9 mm
- Smallest footprint: 6.0 mm x 3.05 mm
- Surface mount package
- IrDA transmit distance: 50 cm typical
- Best Remote Control distance:  $\geq 6.5$  m on-axis
- Fast data rates: from 9.6 kbit/s to 4 Mbit/s
- Low shutdown current: 0.01  $\mu$ A
- Operating Voltage: 2.4 V to 3.6 V
- Reduced pin count: 6 pins
- I/O voltage equal to the supply voltage
- Pin compatibility: TFBS4711 and TFBS5711
- Integrated EMI Protection – no external shield required



- IEC 60825-1 Class 1, Eye Safe
- Qualified for lead (Pb)-free and Sn/Pb processing
- Compliant to IrDA Physical Layer Specification
- Split power supply, transmitter and receiver can be operated from two power supplies with relaxed requirements saving costs, US patent No. 6,157,476
- Lead (Pb)-free device
- Qualified for lead (Pb)-free and Sn/Pb processing (MSL4)
- Device in accordance with RoHS 2002/95/EC and WEEE 2002/96/EC

### Applications

- High-speed data transfer using infrared wireless communication
- Mobile phones
- Camera phones
- PDAs
- MP3 Players
- Digital Cameras
- IrDA Adapters or Dongles

### Package Options

### Ordering Information

Part Number	Qty/Reel or Tube	Description and Remarks
TFBS6711-TR1	1000 pcs	Oriented in carrier tape for side view surface mounting
TFBS6711-TR3	2500 pcs	Oriented in carrier tape for side view surface mounting

Note: A version oriented in the carrier tape for top view mounting is available on request

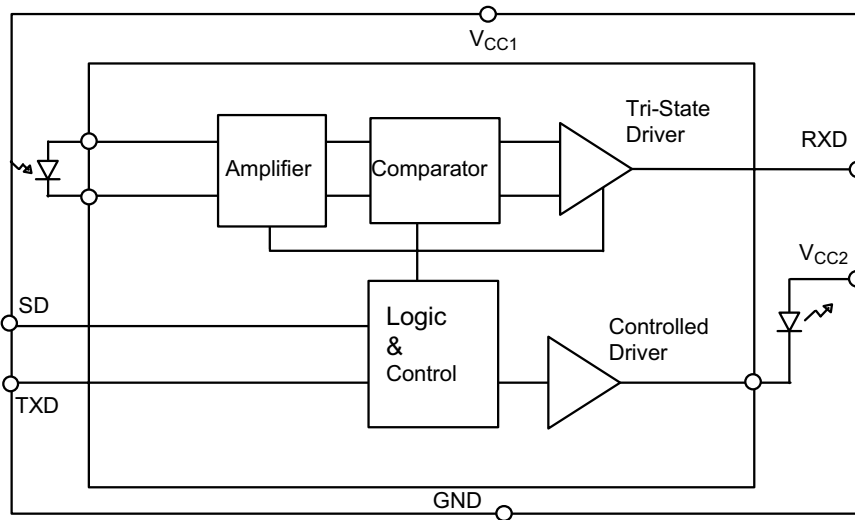
**Functional Block Diagram**

19298

Figure 1. Functional Block Diagramm

**Pin Description**

Pin Number	Function	Description	I/O	Active
1	V <sub>CC2</sub> , IRED Anode	IRED anode to be externally connected to V <sub>CC2</sub> . For higher voltages as 3.6 V an external resistor might be necessary for reducing the internal power dissipation. See derating curves. This pin is allowed to be supplied from an uncontrolled power supply separated from the controlled V <sub>CC1</sub> - supply		
2	TXD	Transmit Data Input	I	HIGH
3	RXD	Received Data Output, push-pull CMOS driver output capable of driving a standard CMOS load. No external pull-up or pull-down resistor is required. Floating with a weak pull-up of 500 kΩ (typ.) in shutdown mode. The RXD output echos the TXD input during transmission.	O	LOW
4	SD	Shutdown, also used for dynamic mode switching	I	HIGH
5	V <sub>CC1</sub>	Supply voltage		
6	GND	Ground		

 TFBS6711  
 Weight: 50 mg

Figure 2. Pinning

### Absolute Maximum Ratings

Reference point Pin, GND unless otherwise noted.

Typical values are for DESIGN AID ONLY, not guaranteed nor subject to production testing.

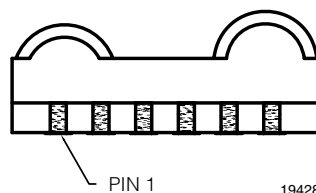
Parameter	Test Conditions	Symbol	Min	Typ.	Max	Unit
Supply voltage range, transceiver	$0\text{ V} < V_{CC2} < 6\text{ V}$	$V_{CC1}$	- 0.5		6	V
Supply voltage range, transmitter	$0\text{ V} < V_{CC1} < 6\text{ V}$	$V_{CC2}$	- 0.5		6.5	V
Input currents	For all Pins, Except IRED Anode Pin				10	mA
Output sinking current					25	mA
Power dissipation		$P_D$			500	mW
Junction temperature		$T_J$			125	°C
Ambient temperature range (operating)		$T_{amb}$	- 25		+ 85	°C
Storage temperature range		$T_{stg}$	- 25		+ 85	°C
Soldering temperature					260	°C
Average output current		$I_{IRED (DC)}$			125	mA
Repetitive pulse output current	$< 90\ \mu\text{s}, t_{on} < 20\%$	$I_{IRED (RP)}$			600	mA
IRED anode voltage		$I_{IREDA}$	- 0.5		6.5	V
Voltage at all inputs and outputs	$V_{in} > V_{CC1}$ is allowed	$V_{in}$	- 0.5		5.5	V
Virtual source size	Method: (1-1/e) encircled energy	d	1.5			mm
Maximum Intensity for Class 1 operation of IEC60825-1 or EN60825-1, edition Jan. 2001					internal limitation to class 1 500	mW/sr
IrDA® specified maximum limit						
Due to the internal limitation measures the device is a "class 1" device. It will not exceed the IrDA® intensity limit of 500 mW/sr						

### Definitions:

In the Vishay transceiver data sheets the following nomenclature is used for defining the IrDA operating modes:

SIR: 2.4 kbit/s to 115.2 kbit/s, equivalent to the basic serial infrared standard with the physical layer version IrPhy 1.0

MIR: 576 kbit/s to 1152 kbit/s

FIR: 4 Mbit/s

VFIR: 16 Mbit/s

IrDA®, the Infrared Data Association, implemented MIR and FIR with IrPHY 1.1, followed by IrPhy 1.2, adding the SIR Low Power Standard. IrPhy 1.3 extended the Low Power Option to MIR and FIR and VFIR was added with IrPhy 1.4. A new version of the standard in any case obsoletes the former version.



## Electrical Characteristics

$T_{amb} = 25\text{ }^{\circ}\text{C}$ ,  $V_{CC} = 2.4\text{ V}$  to  $3.6\text{ V}$  unless otherwise noted.

Typical values are for DESIGN AID ONLY, not guaranteed nor subject to production testing.

Parameters	Test Conditions/Pins	Symbol	Min	Typ.	Max	Unit
<b>Transceiver</b>						
Supply voltage		$V_{CC}$	2.4		3.6	V
Dynamic supply current	Receive mode only. In transmit mode, add additional 85 mA (typ) for IRED current. Add RXD output current depending on RXD load.					
	SD = Low, SIR mode	$I_{CC}$		1.7	3	mA
	SD = Low, MIR/FIR mode	$I_{CC}$		1.9	3.3	mA
Shutdown supply current	SD = High $T = 25\text{ }^{\circ}\text{C}$ , not ambient light sensitive, detector is disabled in shutdown mode	$I_{SD}$			1	$\mu\text{A}$
	SD = High $T = 85\text{ }^{\circ}\text{C}$ , not ambient light sensitive	$I_{SD}$			5	$\mu\text{A}$
Operating temperature range		$T_A$	- 25		+ 85	$^{\circ}\text{C}$
Output voltage low	$I_{OL} = 1\text{ mA}$ $C_{LOAD} = 15\text{ pF}$	$V_{OL}$			0.4	V
Output voltage high	$I_{OH} = - 250\text{ }\mu\text{A}$ $C_{LOAD} = 15\text{ pF}$	$V_{OH}$	$0.9 \times V_{CC}$			V
Internal RXD pull-up		$R_{RXD}$	400	500	600	$\text{k}\Omega$
Input voltage low (TXD, SD)		$V_{IL}$	- 0.5		0.5	V
Input voltage high (TXD, SD)		$V_{IH}$	$V_{CC} - 0.5$		$V_{CC} + 0.5$	V
Input leakage current (TXD, SD)		$I_{ICH}$	- 1	0.05	+ 1	$\mu\text{A}$
Input capacitance (TXD, SD)		$C_I$			5	pF

<sup>\*)</sup> Standard illuminant A

<sup>\*\*)</sup> The typical threshold level is  $0.5 \times V_{CC}$  ( $V_{CC} = 3\text{ V}$ ). It is recommended to use the specified min/max values to avoid increased operating/shutdown currents.

### Optoelectronic Characteristics

T<sub>amb</sub> = 25 °C, V<sub>CC</sub> = 2.4 V to 3.6 V unless otherwise noted.

Typical values are for DESIGN AID ONLY, not guaranteed nor subject to production testing.

Parameter	Test Conditions	Symbol	Min	Typ.	Max	Unit
<b>Receiver</b>						
Minimum irradiance E <sub>e</sub> in angular range **)	9.6 kbit/s to 115.2 kbit/s λ = 850 nm - 900 nm, V <sub>CC</sub> = 2.4 V	E <sub>e</sub>		50 (5)	80 (8)	mW/m <sup>2</sup> (μW/cm <sup>2</sup> )
Minimum irradiance E <sub>e</sub> in angular range MIR mode	1.152 Mbit/s λ = 850 nm - 900 nm, V <sub>CC</sub> = 2.4 V	E <sub>e</sub>		100 (10)		mW/m <sup>2</sup> (μW/cm <sup>2</sup> )
Minimum irradiance E <sub>e</sub> in angular range FIR mode	4 Mbit/s λ = 850 nm - 900 nm, V <sub>CC</sub> = 2.4 V	E <sub>e</sub>		120 (12)	200 (20)	mW/m <sup>2</sup> (μW/cm <sup>2</sup> )
Maximum irradiance E <sub>e</sub> in angular range ***)	λ = 850 nm - 900 nm	E <sub>e</sub>		5 (500)		kW/m <sup>2</sup> (mW/cm <sup>2</sup> )
No detection receiver Input Irradiance (fluorescent light noise suppression)		E <sub>e</sub>	4 (0.4)			mW/m <sup>2</sup> (μW/cm <sup>2</sup> )
Rise time of output signal	10 % to 90 %, C <sub>L</sub> = 15 pF	t <sub>r</sub> (RXD)	10		50	ns
Fall time of output signal	90 % to 10 %, C <sub>L</sub> = 15 pF	t <sub>f</sub> (RXD)	10		50	ns
RXD pulse width of output signal, 50 %, SIR mode	Input pulse length 1.4 μs < P <sub>Wopt</sub> < 25 μs	t <sub>PW</sub>	1.4	1.8	2.6	μs
RXD pulse width of output signal, 50 %, MIR mode	Input pulse length P <sub>Wopt</sub> = 217 ns, 1.152 Mbit/s	t <sub>PW</sub>	110	250	270	ns
RXD pulse width of output signal, 50 %, FIR mode	Input pulse length P <sub>Wopt</sub> = 125 ns, 4 Mbit/s	t <sub>PW</sub>	110		140	ns
RXD pulse width of output signal, 50 %, FIR mode	Input pulse length P <sub>Wopt</sub> = 250 ns, 4 Mbit/s	t <sub>PW</sub>	225		275	ns
RXD output jitter, leading edge	Input irradiance = 150 mW/m <sup>2</sup> , 4 Mbit/s 1.152 Mbit/s ≤ 115.2 kbit/s				20 40 350	ns ns ns
Receiver start up time	After completion of shutdown programming sequence Power on delay				500	μs
Latency <sup>*)</sup>		t <sub>L</sub>			100	μs

Note: All timing data measured with 4 Mbit/s are measured using the IrDA® FIR transmission header. The data given here are valid 5 μs after starting the preamble.

<sup>\*)</sup> **IrDA latency definition:** Receiver **Latency** Allowance (milliseconds or microseconds) is the maximum time after a node ceases transmitting before the node's receiver recovers its specified sensitivity. During this period and also during the receiver start up time (after power on or shut down) the RXD output may be in an undefined state.

<sup>\*\*) IrDA sensitivity definition: Minimum Irradiance E<sub>e</sub> In Angular Range</sup>, power per unit area. The receiver must meet the BER specification while the source is operating at the minimum intensity in angular range into the minimum half-angle range at the maximum Link Length

<sup>\*\*\*) Maximum Irradiance E<sub>e</sub> In Angular Range</sup>, power per unit area. The optical delivered to the detector by a source operating at the maximum intensity in angular range at Minimum Link Length must not cause receiver overdrive distortion and possible related link errors. If placed at the Active Output Interface reference plane of the transmitter, the receiver must meet its bit error ratio (BER) specification.

For more definitions see the document "Symbols and Terminology" on the Vishay Website (<http://www.vishay.com/docs/82512/82512.pdf>).



**Optoelectronic Characteristics, continued**

T<sub>amb</sub> = 25 °C, V<sub>CC</sub> = 2.4 V to 3.6 V unless otherwise noted.

Typical values are for DESIGN AID ONLY, not guaranteed nor subject to production testing.

Parameter	Test Conditions	Symbol	Min	Typ.	Max	Unit
IRED operating current, switched current control	For 3.3-V operation no external resistor is needed.	I <sub>D</sub>	330	440	600	mA
Output leakage IRED current	V <sub>CC</sub> = V <sub>IRED</sub> = 3.3 V, TXD = Low	I <sub>IRED</sub>	- 1		1	μA
Output radiant intensity, s. figure 3, recommended application circuit	V <sub>CC</sub> = V <sub>IRED</sub> = 3.3 V, α = 0° TXD = High, SD = Low, R <sub>1</sub> = 1 Ω	I <sub>e</sub>	45	115	300	mW/sr
Output radiant intensity, s. figure 3, recommended application circuit	V <sub>CC</sub> = V <sub>IRED</sub> = 3.3 V, α = 0°, 15° TXD = High, SD = Low, R <sub>1</sub> = 1 Ω	I <sub>e</sub>	25	75	300	mW/sr
Output radiant intensity	V <sub>CC1</sub> = 3.6 V, α = 0°, 15° TXD = Low or SD = High (Receiver is inactive as long as SD = High)	I <sub>e</sub>			0.04	mW/sr
Output radiant intensity, angle of half intensity		α		± 24		°
Peak - emission wavelength		λ <sub>p</sub>	880		900	nm
Optical rise time, Optical fall time		t <sub>ropt</sub> , t <sub>fopt</sub>	10		40	ns
Optical output pulse duration	Input pulse width 217 ns, 1.152 Mbit/s	t <sub>opt</sub>	200	217	230	ns
Optical output pulse duration	Input pulse width 125 ns, 4 Mbit/s	t <sub>opt</sub>	116	125	134	ns
Optical output pulse duration	Input pulse width 250 ns, 4 Mbit/s	t <sub>opt</sub>	241	250	259	ns
Optical output pulse duration	Input pulse width t < 80 μs Input pulse width t ≥ 80 μs	t <sub>opt</sub> t <sub>opt</sub>	20	t	85	μs μs
Optical overshoot					25	%



**Recommended Circuit Diagram**

Operated at a clean low impedance power supply the TFBS6711 needs no additional external components. However, depending on the entire system design and board layout, additional components may be required (see figure 3).

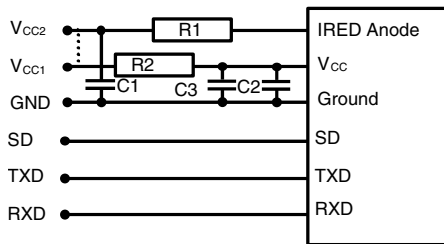

19299

Figure 3. Recommended Application Circuit

The capacitor C1 is buffering the supply voltage and eliminates the inductance of the power supply line. This one should be a Tantalum or other fast capacitor to guarantee the fast rise time of the IRED current. Vishay transceivers integrate a sensitive receiver and a built-in power driver. The combination of both needs a careful circuit board layout. The use of thin, long, resistive and inductive wiring should be avoided. The inputs (RXD, SD) and the output RXD should be directly (DC) coupled to the I/O circuit. The capacitor C2 combined with the resistor R2 is the low pass filter for smoothing the supply voltage. R2, C1 and C2 are optional and dependent on the quality of the supply voltages V<sub>CCx</sub> and injected noise. An unstable power supply with dropping voltage during transmission may reduce the sensitivity (and transmission range) of the transceiver. The placement of these parts is critical. It is strongly recommended to position C2 as close as possible to the transceiver power supply pins. A Tantalum capacitor should be used for C1 while a ceramic capacitor is used for C2.

In addition, when connecting the described circuit to the power supply, low impedance wiring should be used.

When extended wiring is used the inductance of the power supply can cause dynamically a voltage drop at V<sub>CC2</sub>. Often some power supplies are not able to follow the fast current rise time. In that case another 4.7 μF (type, see table under C1) at V<sub>CC2</sub> will be helpful.

Keep in mind that basic RF-design rules for circuit design should be taken into account. Especially longer signal lines should not be used without termination. See e.g. "The Art of Electronics" Paul Horowitz, Winfield Hill, 1989, Cambridge University Press, ISBN: 0521370957.

Table 1. Recommended Application Circuit Components

Component	Recommended Value
C1	4.7 μF, 16 V Vishay part#: 293D 475X9 016B
C2	0.1 μF, Ceramic Vishay part#: VJ1206 Y 104 J XXMT
R1	<b>3.3 V supply voltage:</b> no resistor is necessary, the internal controller is able to control the current
R2	4.7 Ω, 0.125 W

**I/O and Software**

In the description, already different I/Os are mentioned. Different combinations are tested and the function verified with the special drivers available from the I/O suppliers. In special cases refer to the I/O manual, the Vishay application notes, or contact directly Vishay Sales, Marketing or Application.

### Mode Switching

The TFBS6711 is in the SIR mode after power on as a default mode, therefore the FIR data transfer rate has to be set by a programming sequence using the TXD and SD inputs as described below. The low frequency mode covers speeds up to 115.2 kbit/s. Signals with higher data rates should be detected in the high frequency mode. Lower frequency data can also be received in the high frequency mode but with reduced sensitivity. To switch the transceivers from low frequency mode to the high frequency mode and vice versa, the programming sequences described below are required.

### Setting to the High Bandwidth Mode (0.576 Mbit/s to 4 Mbit/s)

1. Set SD input to logic "HIGH".
2. Set TXD input to logic "HIGH". Wait  $t_s \geq 200$  ns.
3. Set SD to logic "LOW" (this negative edge latches state of TXD, which determines speed setting).
4. After waiting  $t_h \geq 200$  ns TXD can be set to logic "LOW". The hold time of TXD is limited by the maximum allowed pulse length. TXD is now enabled as normal TXD input for the high bandwidth mode.

### Setting to the Lower Bandwidth Mode (2.4 kbit/s to 115.2 kbit/s)

1. Set SD input to logic "HIGH".
2. Set TXD input to logic "LOW". Wait  $t_s \geq 200$  ns.
3. Set SD to logic "LOW" (this negative edge latches state of TXD, which determines speed setting).
4. TXD must be held for  $t_h \geq 200$  ns. TXD is now enabled as normal TXD input for the lower bandwidth mode.

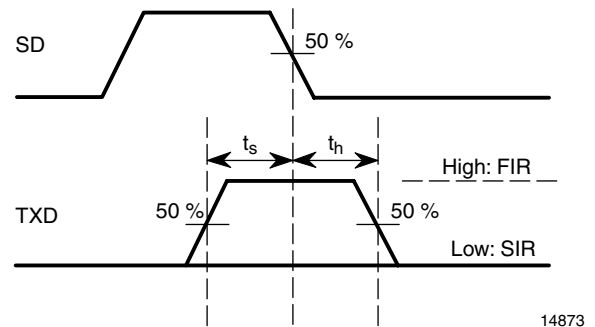

14873

Figure 4. Mode Switching Timing Diagram

### Truth table

Inputs			Outputs	
SD	TXD	Input irradiance $\text{mW/m}^2$	RXD	Transmitter
high	x	x	weakly pulled (500 $\text{k}\Omega$ ) high	0
low	high	x	low active (echo)	$I_e$
low	high > 80 $\mu\text{s}$	x	high	0
low	low	< 4	high	0
low	low	> Min. irradiance $E_e$ in angular range < Max. irradiance $E_e$ in angular range	low (active)	0
low	low	> Max. irradiance $E_e$ in angular range	x	0



**Recommended Solder Profiles**

**Solder Profile for Sn/Pb soldering**

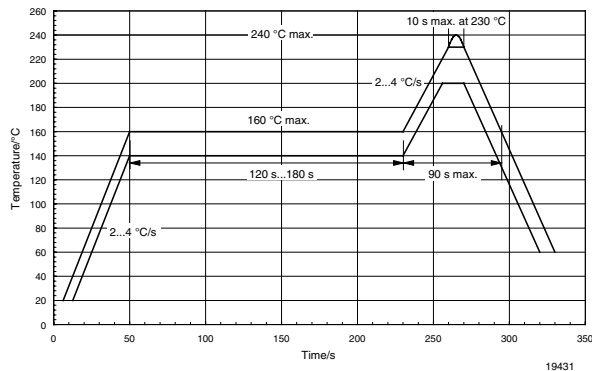

Figure 5. Recommended Solder Profile for Sn/Pb soldering

**Lead (Pb)-Free, Recommended Solder Profile**

The TFBS6711 is a lead (Pb)-free transistor and qualified for lead (Pb)-free processing. For lead (Pb)-free solder paste like Sn(3.0-4.0)Ag(0.5-0.9)Cu, there are two standard reflow profiles: Ramp-Soak-Spike (RSS) and Ramp-To-Spike (RTS). The Ramp-Soak-Spike profile was developed primarily for reflow ovens heated by infrared radiation. With widespread use of forced convection reflow ovens the Ramp-To-Spike profile is used increasingly. Shown below in figure 6 is VISHAY's recommended profiles for use with the TFBS6711 transistors. For more details please refer to Application note: SMD Assembly Instruction.

**Wave Soldering**

For TFDUxxxx and TFBSxxxx transistor devices wave soldering is not recommended.

**Manual Soldering**

Manual soldering is the standard method for lab use. However, for a production process it cannot be recommended because the risk of damage is highly dependent on the experience of the operator. Nevertheless, we added a chapter to the above mentioned application note, describing manual soldering and desoldering.

**Storage**

The storage and drying processes for all VISHAY transistors (TFDUxxxx and TFBSxxx) are equivalent to MSL4.

The data for the drying procedure is given on labels on the packing and also in the application note "Taping, Labeling, Storage and Packing" (<http://www.vishay.com/docs/82601/82601.pdf>).

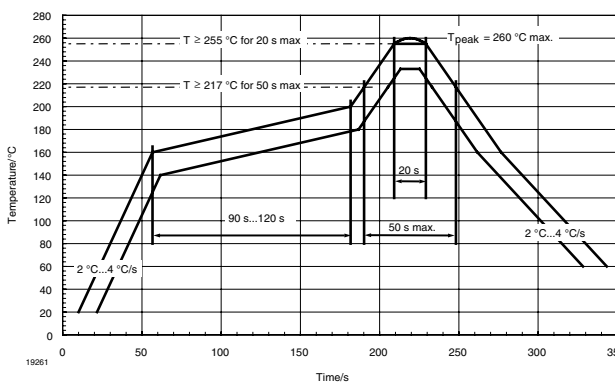

Figure 6. Solder Profile, RSS Recommendation

**TFBS4711, TFBS5711, TFBS6711, and TFBS6712 Package  
(Mechanical Dimensions)**

 Figure 7. Package drawing, tolerances: Height + 0.1, - 0.2 mm, otherwise  $\pm 0.2$  mm if not indicated

Figure 8. Soldering footprints

**Design Rules for Optical Windows**

 For optical windows see the application note on the web <http://www.vishay.com/docs/82506/82506.pdf>.

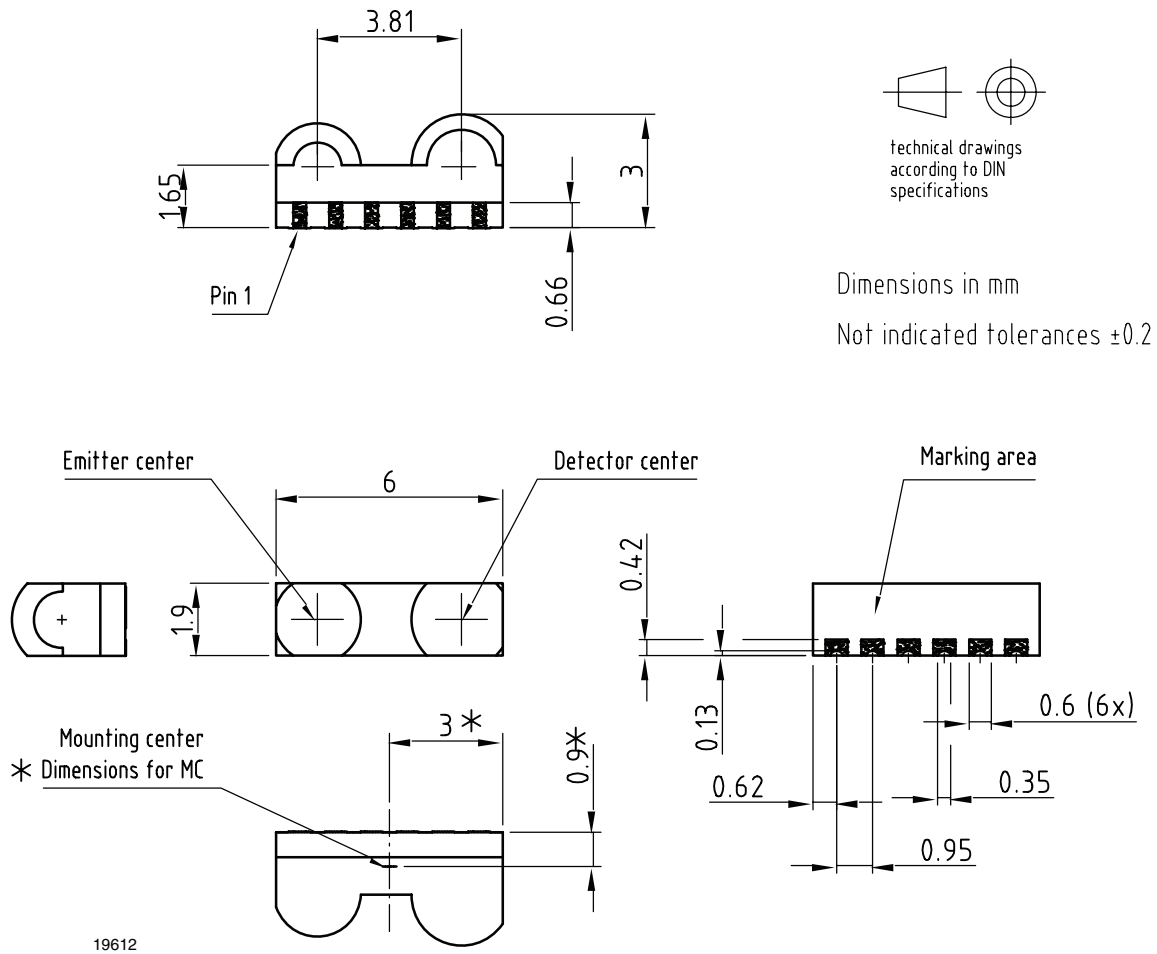
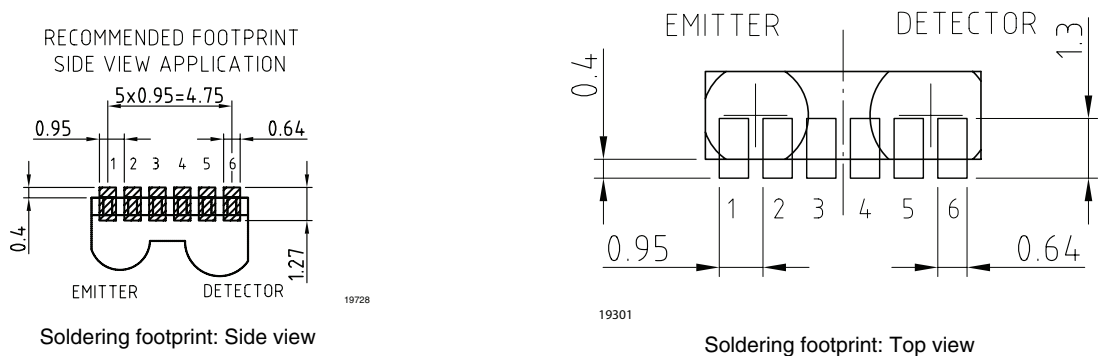
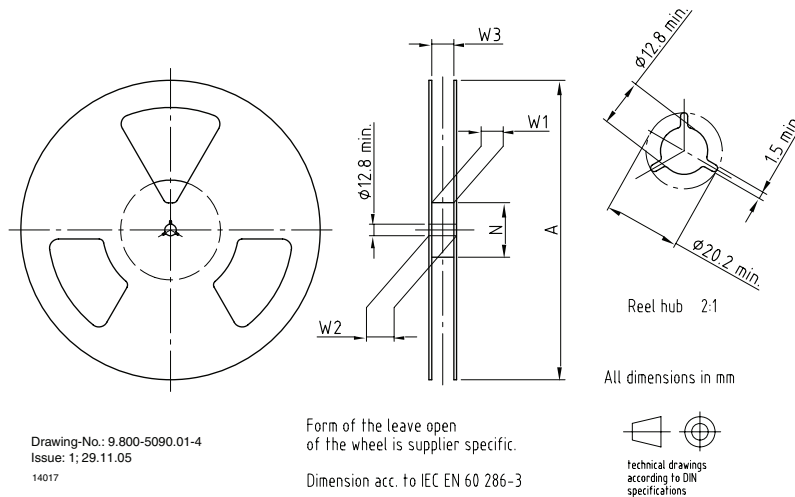

Drawing-No.: 9.800-5090.01-4  
Issue: 1; 29.11.05  
14017

Form of the leave open  
of the wheel is supplier specific.

Dimension acc. to IEC EN 60 286-3

technical drawings  
according to DIN  
specifications

Tape Width	A max.	N	W <sub>1</sub> min.	W <sub>2</sub> max.	W <sub>3</sub> min.	W <sub>3</sub> max.
mm	mm	mm	mm	mm	mm	mm
16	330	50	16.4	22.4	15.9	19.4

Figure 9. Reel dimensions [mm]

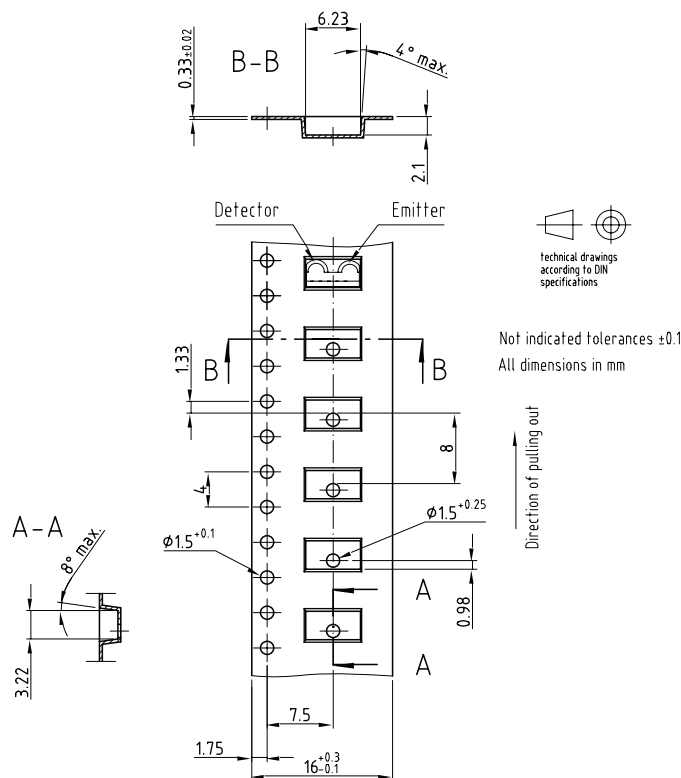

Drawing-No.: 9.700-5294.01-4  
Issue: prel. copy; 24.11.04

Figure 10. Tape dimensions [mm] TFBS6711-TT3

19303

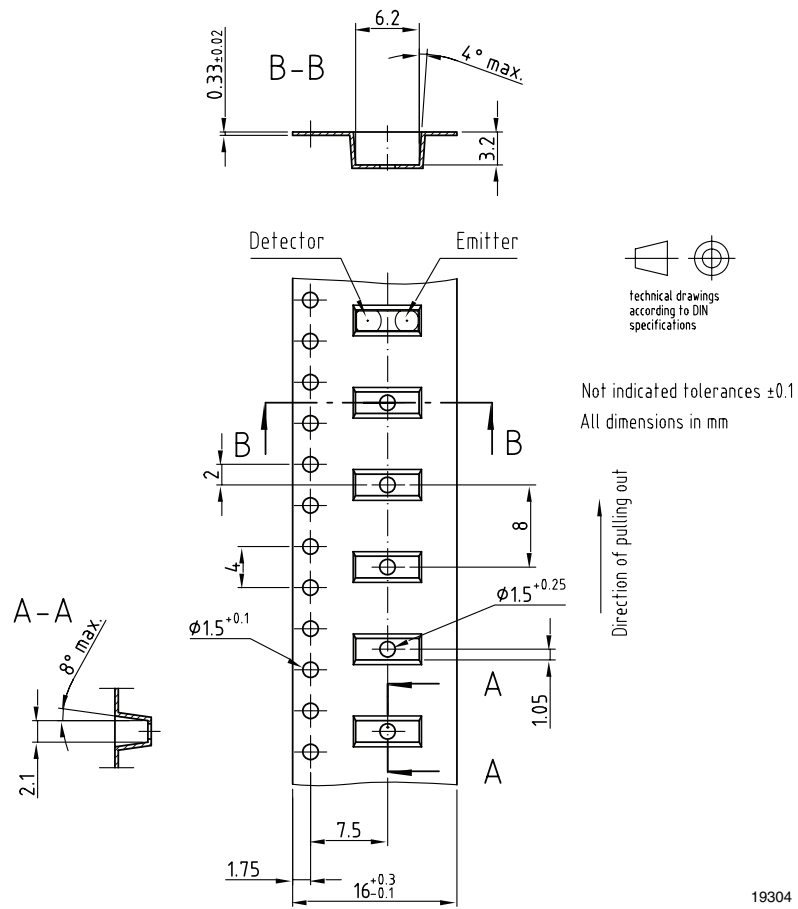

Drawing-No.: 9.700-5295.01-4  
 Issue: prel. copy; 24.11.04

Figure 11. Tape dimensions [mm] TFBS6711-TR3



## Ozone Depleting Substances Policy Statement

It is the policy of Vishay Semiconductor GmbH to

1. Meet all present and future national and international statutory requirements.
2. Regularly and continuously improve the performance of our products, processes, distribution and operating systems with respect to their impact on the health and safety of our employees and the public, as well as their impact on the environment.

It is particular concern to control or eliminate releases of those substances into the atmosphere which are known as ozone depleting substances (ODSs).

The Montreal Protocol (1987) and its London Amendments (1990) intend to severely restrict the use of ODSs and forbid their use within the next ten years. Various national and international initiatives are pressing for an earlier ban on these substances.

Vishay Semiconductor GmbH has been able to use its policy of continuous improvements to eliminate the use of ODSs listed in the following documents.

1. Annex A, B and list of transitional substances of the Montreal Protocol and the London Amendments respectively
2. Class I and II ozone depleting substances in the Clean Air Act Amendments of 1990 by the Environmental Protection Agency (EPA) in the USA
3. Council Decision 88/540/EEC and 91/690/EEC Annex A, B and C (transitional substances) respectively.

Vishay Semiconductor GmbH can certify that our semiconductors are not manufactured with ozone depleting substances and do not contain such substances.

We reserve the right to make changes to improve technical design and may do so without further notice.

Parameters can vary in different applications. All operating parameters must be validated for each customer application by the customer. Should the buyer use Vishay Semiconductors products for any unintended or unauthorized application, the buyer shall indemnify Vishay Semiconductors against all claims, costs, damages, and expenses, arising out of, directly or indirectly, any claim of personal damage, injury or death associated with such unintended or unauthorized use.

Vishay Semiconductor GmbH, P.O.B. 3535, D-74025 Heilbronn, Germany



## Notice

Specifications of the products displayed herein are subject to change without notice. Vishay Intertechnology, Inc., or anyone on its behalf, assumes no responsibility or liability for any errors or inaccuracies.

Information contained herein is intended to provide a product description only. No license, express or implied, by estoppel or otherwise, to any intellectual property rights is granted by this document. Except as provided in Vishay's terms and conditions of sale for such products, Vishay assumes no liability whatsoever, and disclaims any express or implied warranty, relating to sale and/or use of Vishay products including liability or warranties relating to fitness for a particular purpose, merchantability, or infringement of any patent, copyright, or other intellectual property right.

The products shown herein are not designed for use in medical, life-saving, or life-sustaining applications. Customers using or selling these products for use in such applications do so at their own risk and agree to fully indemnify Vishay for any damages resulting from such improper use or sale.