

AT-232-PIN

Digital Attenuator
30.0 dB, 4-Bit, TTL Driver, DC-2.0 GHz

Rev. V5

Features

- Attenuation: 2 dB steps to 30 dB
- Temperature Stability: ± 0.18 dB from -55°C to $+85^{\circ}\text{C}$ Typical
- Low DC Power Consumption
- Hermetic Surface Mount Package
- Fast Switching Speed, 12 ns Typical
- 50 Ohm Nominal Impedance
- Lead-Free CR-6 Package
- 260°C Reflow Compatible
- RoHS* Compliant

Description

M/A-COM's AT-232-PIN is a GaAs FET 4-bit digital attenuator with a 2 dB minimum step size and 30 dB total attenuation. This attenuator is in a hermetically sealed ceramic 16-lead surface mount package. The AT-232-PIN is ideally suited for use where accuracy, fast switching, very low power consumption and low intermodulation products are required. Typical applications include dynamic range setting in precision receiver circuits and other gain/leveling control circuits. Environmental screening is available. Contact the factory for information.

Ordering Information

Part Number	Package
AT-232-PIN	Bulk Packaging

Note: Reference Application Note M513 for reel size information.

Functional Schematic

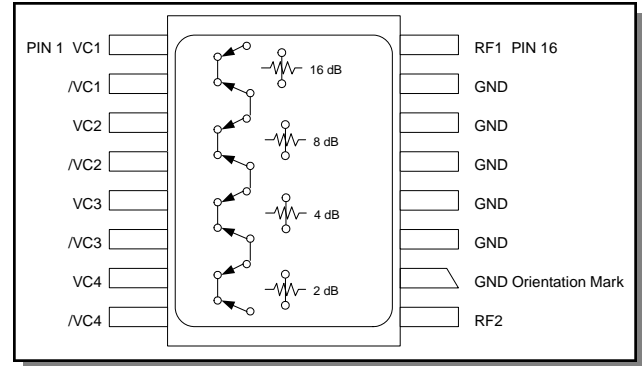

Pin Configuration

Pin No.	Function	Pin No.	Function
1	VC1	9	RF2
2	/VC1	10	GND
3	VC2	11	GND
4	/VC2	12	GND
5	VC3	13	GND
6	/VC3	14	GND
7	VC4	15	GND
8	/VC4	16	RF1

The metal bottom of the case must be connected to RF and DC ground.

* Restrictions on Hazardous Substances, European Union Directive 2002/95/EC.

Electrical Specifications: From -55°C to $+85^{\circ}\text{C}$ ¹

Parameter	Test Conditions	Frequency	Units	Min	Typ	Max
Reference Insertion Loss	—	DC - 0.5 GHz	dB	—	—	2.0
		DC - 1.0 GHz	dB	—	—	2.3
		DC - 2.0 GHz	dB	—	—	2.5
Attenuation Accuracy ²	Any Single Bit	DC - 1.0 GHz DC - 2.0 GHz	$\pm (0.15 \text{ dB} + 3\% \text{ of atten setting in dB}) \text{ dB}$ $\pm (0.2 \text{ dB} + 3\% \text{ of atten setting in dB}) \text{ dB}$ Or $\pm 0.45 \text{ dB}$, whichever is greater			
	Any Combination of Bits	DC - 1.0 GHz DC - 2.0 GHz	$\pm (0.22 \text{ dB} + 3\% \text{ of atten setting in dB}) \text{ dB}$ $\pm (0.25 \text{ dB} + 4\% \text{ of atten setting in dB}) \text{ dB}$ Or $\pm 0.45 \text{ dB}$, whichever is greater			
VSWR	—	DC - 2.0 GHz	Ratio	—	—	1.6:1
Trise, Tfall	10% to 90%	—	ns	—	12	—
Ton, Toff	50% Control to 90/10% RF	—	ns	—	18	—
Transients	In-Band (peak-peak)	—	mV	—	25	—
1 dB Compression	Input Power Input Power	0.05 GHz	dBm	—	+20	—
		0.5 - 2.0 GHz	dBm	—	+28	—
Input IP3	For two-tone Input Power Up to +5 dBm	0.05 GHz	dBm	—	+40	—
		0.5 - 2.0 GHz	dBm	—	+50	—
Input IP2	For two-tone Input Power Up to +5 dBm	0.05 GHz	dBm	—	+45	—
		0.5 - 2.0 GHz	dBm	—	+68	—
Input Leakage Current (Low)	-0.2 to 0V	—	μA	—	—	20
Input Leakage Current (High)	-8.0 to -5.0V	—	μA	—	—	200

1. All specifications apply when operated with control voltages of 0.0V to -5.0V.
2. This attenuator is guaranteed monotonic.

Absolute Maximum Ratings^{3,4}

Parameter	Absolute Maximum
Max Input Power 0.05 GHz 0.5 - 2.0 GHz	+27 dBm +34 dBm
Control Voltage	$-8.5 \text{ V} \leq V_c \leq +5 \text{ V}$
Operating Temperature	-55°C to $+125^{\circ}\text{C}$
Storage Temperature	-65°C to $+150^{\circ}\text{C}$

3. Exceeding any one or combination of these limits may cause permanent damage to this device.
4. M/A-COM does not recommend sustained operation near these survivability limits.

AT-232-PIN



Digital Attenuator
30.0 dB, 4-Bit, TTL Driver, DC-2.0 GHz

Rev. V5

Handling Procedures

Please observe the following precautions to avoid damage:

Static Sensitivity

Gallium Arsenide Integrated Circuits are sensitive to electrostatic discharge (ESD) and can be damaged by static electricity. Proper ESD control techniques should be used when handling these devices.

Typical Performance Curves

Ref. Insertion Loss vs. Frequency

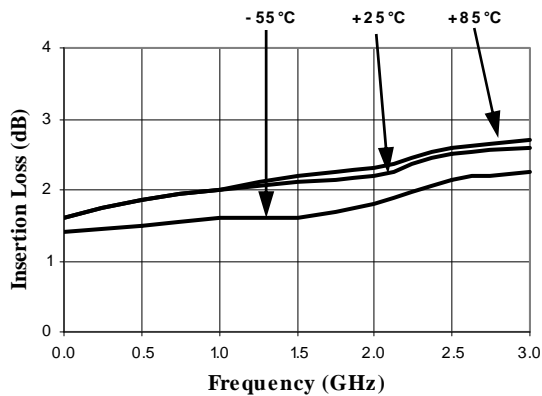

Truth Table (Digital Attenuator)

Control Inputs								Atten. (dB)
/VC4	VC4	/VC3	VC3	/VC2	VC2	/VC1	VC1	
-5V	0V	-5V	0V	-5V	0V	-5V	0V	Ref.
0V	-5V	-5V	0V	-5V	0V	-5V	0V	2 dB
-5V	0V	0V	-5V	-5V	0V	-5V	0V	4 dB
-5V	0V	-5V	0V	0V	-5V	-5V	0V	8 dB
-5V	0V	-5V	0V	-5V	0V	0V	-5V	16 dB
0V	-5V	0V	-5V	0V	-5V	0V	-5V	30 dB

VSWR vs. Frequency

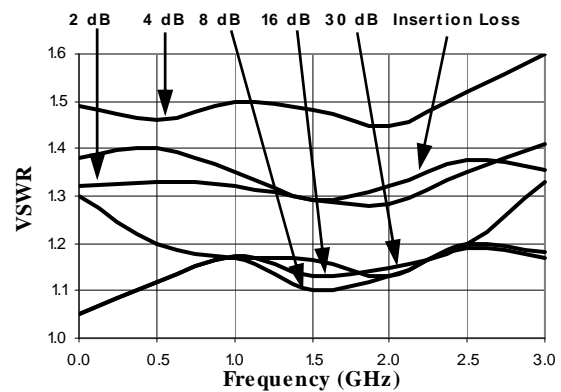

Attenuation Accuracy vs. Frequency

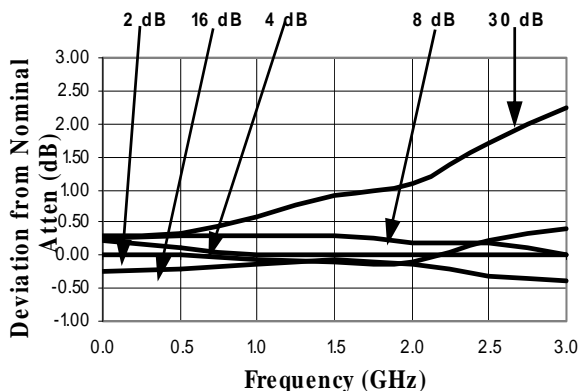

AT-232-PIN

Digital Attenuator
30.0 dB, 4-Bit, TTL Driver, DC-2.0 GHz

Rev. V5

Lead-Free, CR-6 Ceramic Package†

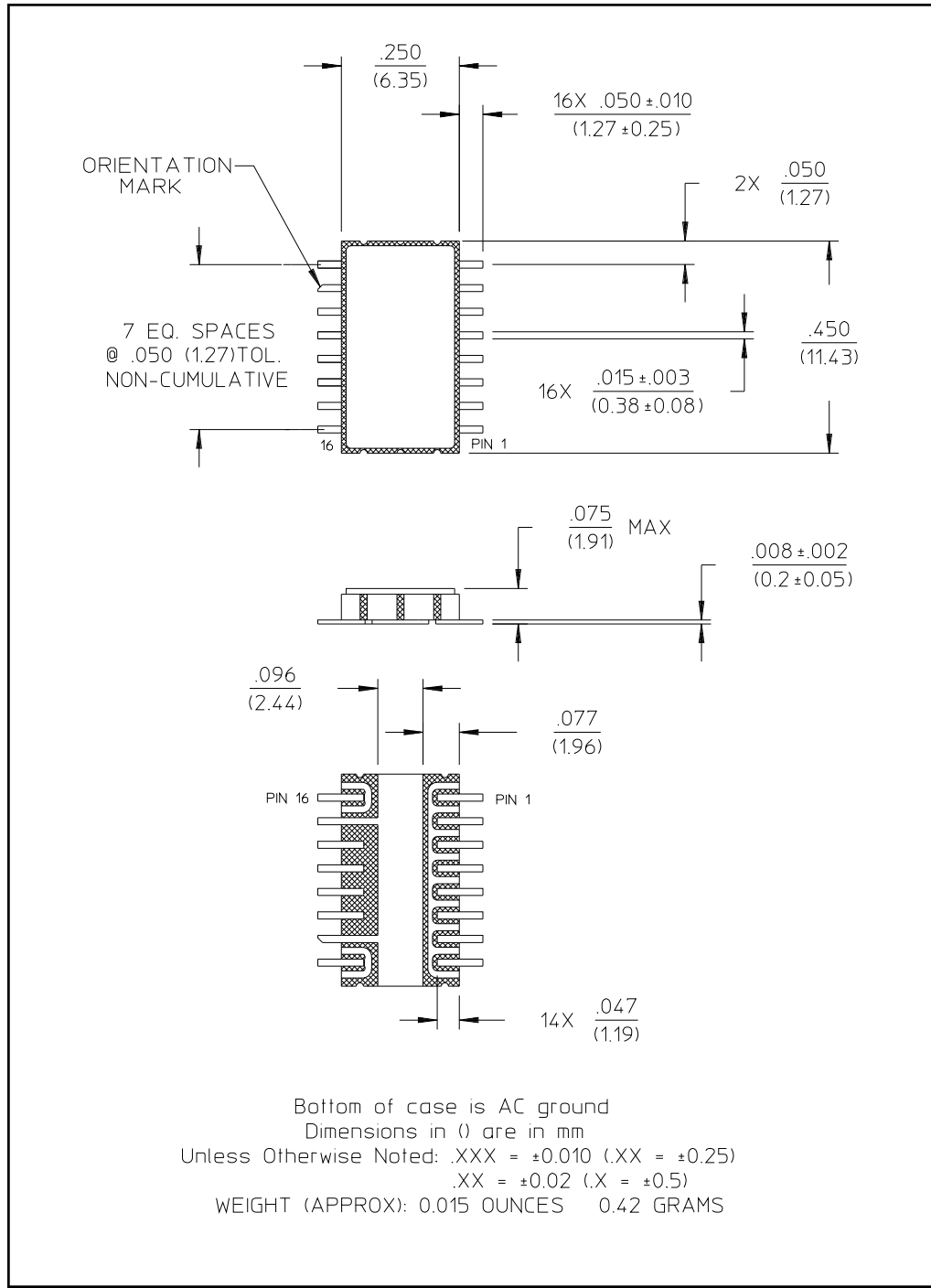

† Reference Application Note M538 for lead-free solder reflow recommendations.