

EPC1013P & EPC1013P-LF



- Designed for Low Common Mode Noise
- 75% Typ. Efficiency at Full Load @ Nominal Input Voltage
- Input Filter to Reduce Input Ripple Current
- Add “-LF” after part number for Lead-Free
- Storage Temperature : -40°C to +125°C
- Operating Temperature : 0°C to +70°C
- Input/Output Isolation : 500 Vrms
- Regulated Output

Electrical Specifications

Parameters	Min.	Typ.	Max.	Units
Input Voltage	10.8	12	13.2	Volts
Output Voltage	---	9 ± 5%	---	Volts
Output Current	---	---	200	mA
Output Ripple & Noise @ 20 MHz BW	---	---	100	mV p-p

Package

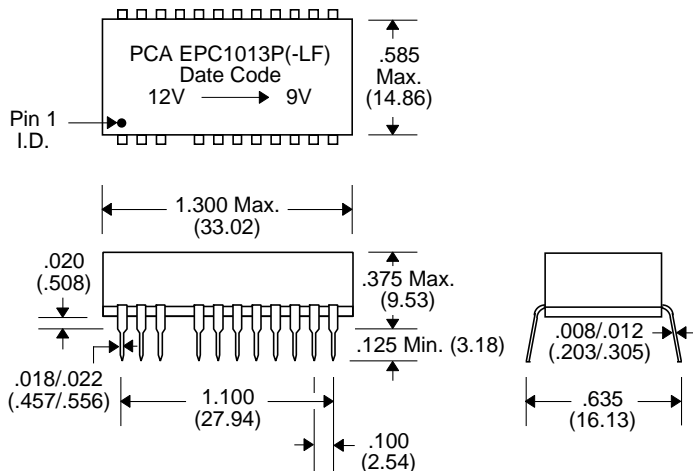

Pin 4 removed, Pins 2-9 & 16-23 not connected

Pin Connections

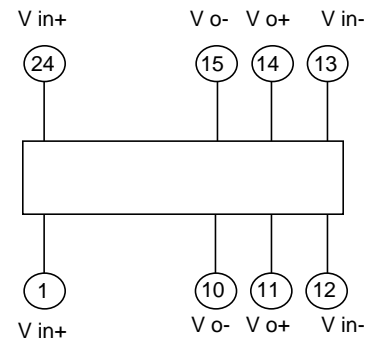

Notes :	EPC1013P	EPC1013P-LF
1. Lead Finish	SnPb	Hot Tin Dip (Sn)
2. Peak Temperature Rating (Wave Solder Process Only)	260°C	260°C
3. Weight	9.225 grams	9.225 grams
4. Packaging Information (Tube)	15 pieces/tube	15 pieces/tube

Unless Otherwise Specified Dimensions are in Inches /mm ± .010 / .25