

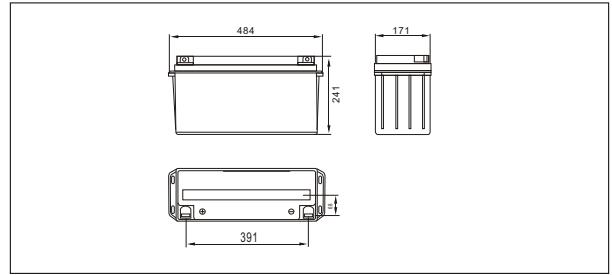

SW121500E(12V150AH)



Outer dimensions (mm)



Specifications

Nominal Voltage		12V
Rated capacity (10 hour rate)		150 Ah
Dimensions	Total Height	241 mm (9.49inches)
	Height	241 mm (9.49inches)
	Length	484 mm (19.1 inches)
	Width	171 mm (6.73 inches)
Weight Approx		45.5 Kg (100.6lbs)

Terminal Type (mm)

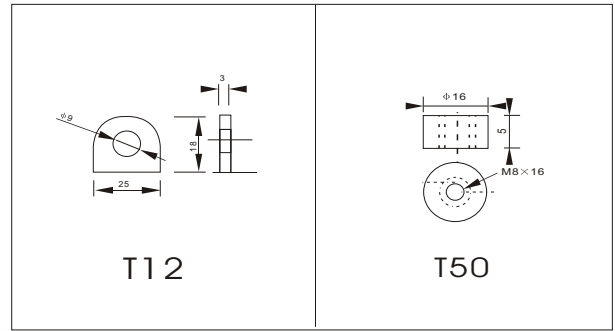

Characteristics

Capacity 25°C(77°F)	10 hour rate(15A)	150 AH
	5 hour rate(24A)	120AH
	1 hour rate(82.5A)	82.5 AH
Internal Resistance	1.5 hour discharge to 10.5V	60 A
	Full charged Battery at 25°C(77°F)	4.6 mΩ
Capacity affected by Temperature (10hour rate)	40°C(104°F)	102%
	25°C(77°F)	100%
	0°C(32°F)	85%
	-15°C(5°F)	65%
Self-Discharge at 25°C(77°F)	Capacity after 3 month storage	91%
	Capacity after 6 month storage	82%
	Capacity after 12 month storage	64%
Terminal		T12、T50
Charge (constant Voltage)	Cycle	Initial Charging Current less than 37.5 A Voltage 14.10-14.40V
	Float	Voltage 13.50-13.80V

Discharge Curves 25°C(77°F)

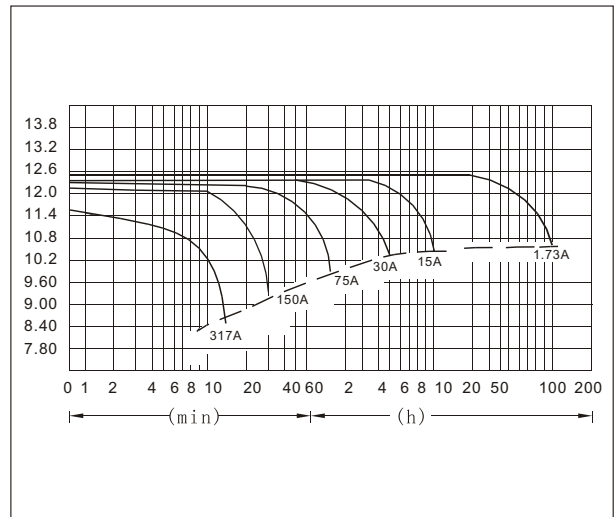

Constant Current(Amp) and Constant Power(Watt) Discharge Table at 25°C(77°F)

Time		10min	30min	1h	3h	4h	5h	8h	10h	20h	50h	100h
9.60V	A	317	171	90	38.6	30.0	24.8	17.4	15.8	8.51	3.54	1.82
	W	3515	1832	1042	446	347	287	202	182	98.5	42.2	21.6
10.20V	A	308	167	84.6	37.5	29.3	24.3	17.1	15.4	8.30	3.42	1.77
	W	3380	1815	980	434	339	281	198	178	96.1	40.7	21.0
10.50V	A	294	158	82	36.6	28.8	24.0	17.0	15.0	8.19	3.36	1.73
	W	3276	1713	948	424	334	278	196	176	94.8	40.1	20.6
10.80V	A	275	153	79	35.7	28.4	23.4	16.5	14.6	8.10	3.30	1.71
	W	3149	1648	907	416	327	272	192	175	94.3	39.3	20.4
11.10V	A	252	141	75	34.5	27.5	22.8	16.1	14.25	7.70	3.24	1.65
	W	3095	1635	883	411	325	271	191	170	91.6	38.6	19.7