

DIN-sized (48 x 48 mm) Temperature Controller With Digital Setting

- Compact, low-cost Temperature Controller
- Incorporates proportional adjustment and reset adjustment function.
- Incorporates a plug-in socket, thus allows to DIN-track and flush mounting.

Ordering Information

■ Temperature Controllers

Setting method	Indication method	Control mode	Output	Model		
				Thermocouple (with sensor burnout detection circuit)		Platinum resistance thermometer JPt100
Digital setting	Digital indication	ON/OFF	Relay	E5C4-R20K	E5C4-R20J	E5C4-R20P
			Voltage (for driving SSR)	E5C4-Q20K	E5C4-Q20J	E5C4-Q20P
		P	Relay	E5C4-R40K	E5C4-R40J	E5C4-R40P
			Voltage (for driving SSR)	E5C4-Q40K	E5C4-Q40J	E5C4-Q40P

Note: When placing an order, specify the standard temperature range and supply voltage in addition to the model number.
(e.g., E5C4-R20K 0°C to 399°C 100/110 VAC)

■ Accessories (Order Separately)

Name	Model
Front Connecting Socket	P2CF-08
Back Connecting Socket (for flush mounting)	P3G-08
Watertight Cover	Y92A-48N

■ Temperature Ranges

Input		Thermocouple			Platinum resistance thermometer
		K (CA) Chromel vs. alumel		J (IC) Iron vs. constantan	JPt100
Range	°C	0 to 399	0 to 999	0 to 399	0 to 99.9
	°F	32 to 799	32 to 999	32 to 999 32 to 799	32 to 199
Setting		1°C/°F	1°C/°F	1°C/°F	0.1°C/1°F

Specifications

■ Ratings

Supply voltage	100/110, 200/220, 110/120, 220/240 VAC, 50/60 Hz
Operating voltage range	90% to 110% of rated supply voltage
Power consumption	Approx. 2 VA
Input	Thermocouple (with sensor burnout detection circuit) or platinum resistance thermometer
Control mode	ON/OFF or P control
Setting method	Digital setting
Indication method	Digital indication
Control output	Relay output: SPDT, 3 A at 250 VAC, resistive load (switching capacity: 330 VA) Voltage output for SSR: 10 mA at 5 VDC (with short-circuit protection) H: 5±1 V; L: 0.5 V max.

■ Characteristics

Setting accuracy	±2% FS max.
Indication accuracy	±2% FS max.
Indication range	Within set temperature range
Hysteresis	Approx. 0.2% FS (fixed)
Proportional band	3% FS (fixed)
Proportional period	Relay output: Approx. 20 s Voltage output: Approx. 2 s
Reset range (see note 1)	±1.5% FS min. (variable)
Insulation resistance	20 MΩ min. (at 500 VDC)
Dielectric strength	2,000 VAC, 50/60 Hz for 1 min between charged terminals and uncharged metallic parts
Vibration resistance	Malfunction: 10 to 55 Hz, 0.3-mm double amplitude for 10 min each in X, Y, and Z directions Destruction: 16.7 Hz, 4-mm double amplitude for 2 hrs each in X, Y, and Z directions
Shock resistance	Malfunction: 147 m/s ² (15G), 3 times each in 6 directions Destruction: 294 m/s ² (30G), 3 times each in 6 directions
Life expectancy	Mechanical: 10,000,000 operations min. Electrical: 100,000 operations min. (3 A at 110 VAC, resistive load)
Ambient temperature	Operating: -10°C to 55°C (with no icing)
Ambient humidity	Operating: 45% to 85%
Enclosure ratings	Front panel: IEC standard IP40 (see note 2) Terminals: IEC standard IP00
Weight	Approx. 200 g (with flush-mounting adapter)

- Note:**
1. The reset adjuster of any E5C4 model with ON/OFF control is used to correct any error of the set temperature that is displayed so that the displayed temperature will coincide with the temperature that has been preset. The reset shaft of any E5C4 is used to reset the E5C4 model with proportional control.
 2. The model number of the special watertight cover conforming to IP66, NEMA4 is Y92A-48N.

Nomenclature

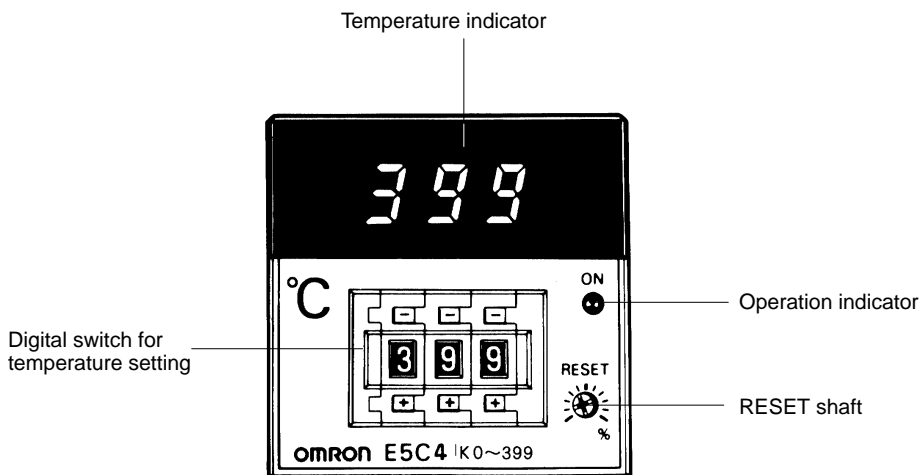

Negative Value Display (Example: -18°C)

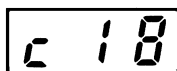

Indicates that the temperature is below 0°C.

Note: The E5C4 does not have a parameter display any temperature below 0°C. Therefore, the accuracy of any temperature below 0° displayed by the E5C4 cannot be guaranteed.

Overflow Display

The following will be displayed if the sensor burnout detection circuit operates or the process value exceeds the temperature range that has been preset.
(Except models with a set temperature range from 0°C to 399°C, 32°F to 799°F and 32°F to 199°F.)

0°C to 999°C or 0°C to 99.9°C
or 32°F to 999°F

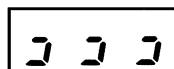

0°C to 399°C

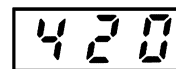

32°F to 799°F



32°F to 199°F

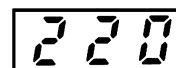

Operation Indicator

Indicator		Output
Red	Lit	ON
	Not lit	OFF

Dimensions

Note: All units are in millimeters unless otherwise indicated.

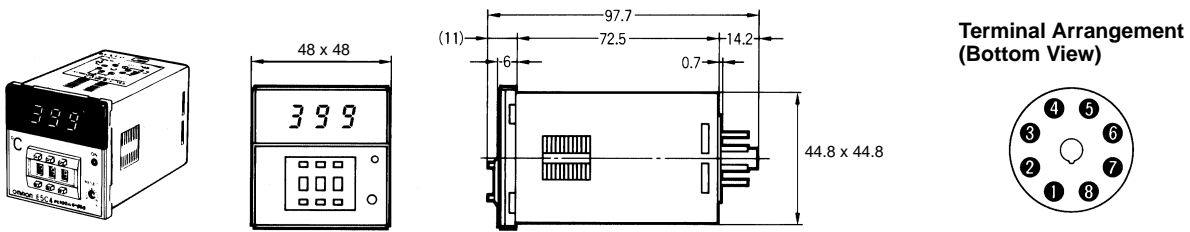

Dimensions with Flush-mounting Adapter (Accessory), and Back Connecting Socket (Sold Separately)

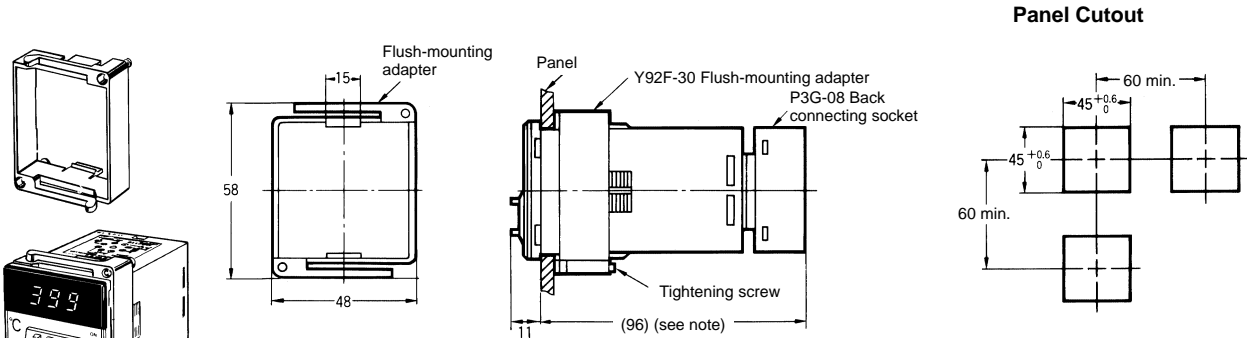

Note: 109 mm for US08 Back Connecting Socket

Side-by-side Mounting of N Controllers

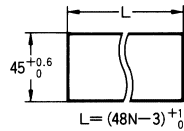

N	2	3	4	5	6
L	93 ⁺¹ ₀	141 ⁺¹ ₀	189 ⁺¹ ₀	237 ⁺¹ ₀	285 ⁺¹ ₀

- Note:** 1. Recommended panel thickness is 1 to 4 mm.
- 2. Close side-by-side mounting is possible (in a single direction).

Accessories (Order Separately)

P2CF-08 Front Connecting Socket

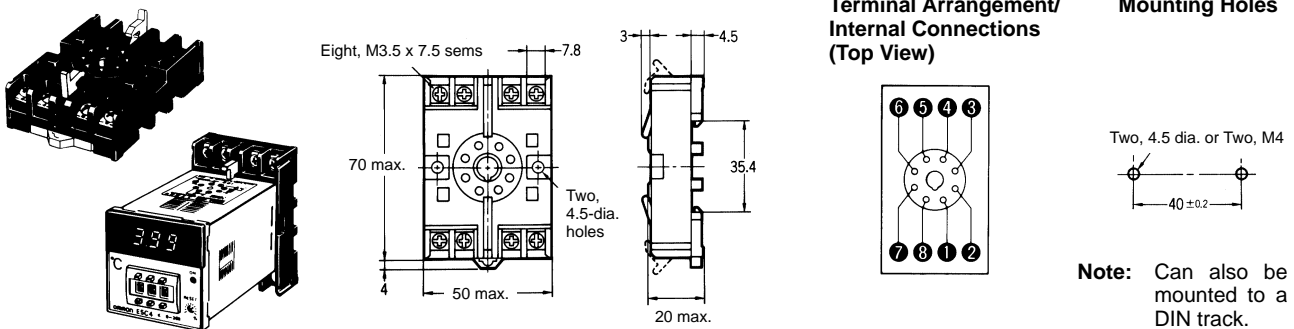

Note: Can also be mounted to a DIN track.

P3G-08 Back Connecting Socket (for Flush Mounting)

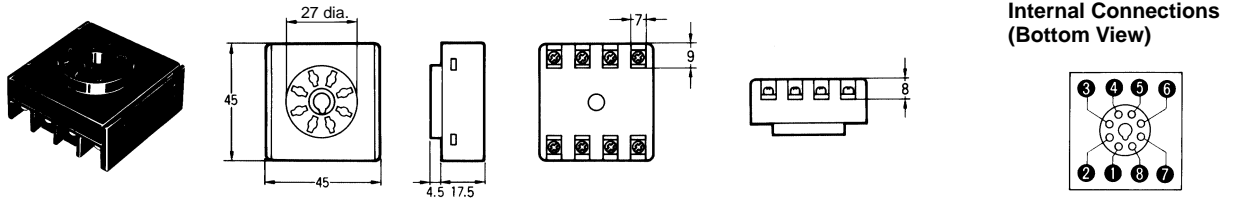

Terminal Arrangement/
Internal Connections
(Bottom View)

Installation

■ Connections

Input

Connect a thermocouple or platinum resistance thermometer to the E5C4 as shown in the following illustration.

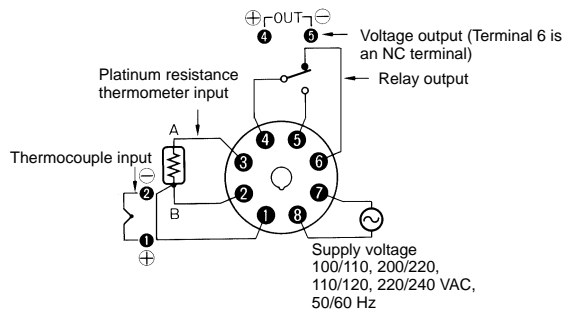

Output

If the load circuit is a heating control system, be sure to connect the load to terminals 4 and 5. If the load circuit is a cooling control system, be sure to connect the load to terminals 4 and 6. If the heating control system is connected to terminals 4 and 6 or the cooling control system is connected to terminals 4 and 5, the temperature of the heating control system or cooling control system will be abnormal and a serious accident may result.

If the E5C4 is in frequent operation, such as proportional operation, add an appropriate external relay to the E5C4 by considering the capacity of the load and the life of the relay.

Do not ground the output of any E5C4 that has voltage output, otherwise the process temperature may not be accurate.

Power Supply

If a single power supply is used for the E5C4 and the load, the supply voltage of the power supply may vary greatly when the load is open or closed if the capacity of the power supply is not large enough. Make sure that the capacity of the power supply is large enough so that the supply voltage range will be always from 90% to 110% of the rated supply voltage.

The E5C4 operates at either 50 or 60 Hz.

Precautions

Mounting

Track Mounting (E5C4 with P2CF-08)

When mounting two or more E5C4 models with track-mounting sockets, leave a space of approximately 20 mm on both sides of the sockets where hooks are located.

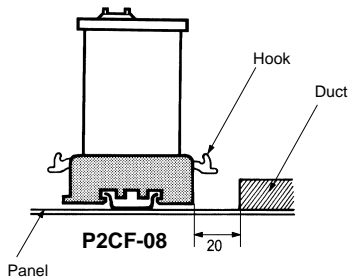

Flush Mounting

Insert E5C4 into the square hole of the panel and insert an adapter from the back so that there will be no space between E5C4 and the panel. Then, secure the E5C4 with a screw.

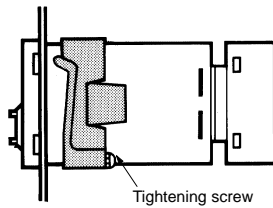

The P3G-08 can be wired in the same way as the P2CF-08.

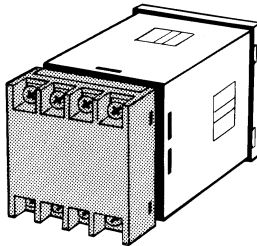

Dismounting

If flush mounted, loosen the screw of the adapter and disengage the hooks for dismounting.

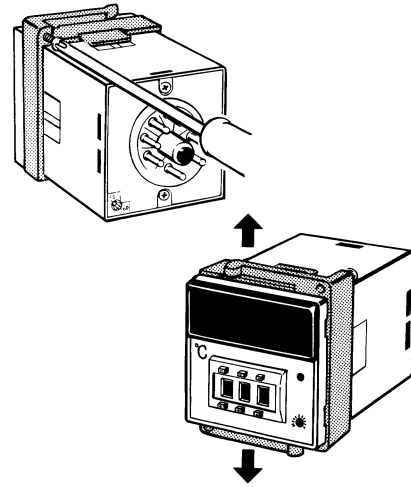

Temperature Setting

The leftmost digit of any E5C4 that has a set temperature range from 0°C to 399°C will increase by 1 within a range of 0 to 3 each time the push button for the leftmost digit is pressed. The leftmost digit indicating 3 will change to 0 when the push button is pressed.

Others

Do not remove the housing of the E5C4, otherwise the housing may break.

To clean the surface of the E5C4, use a soft cloth wet with neutral detergent or alcohol. Do not use any organic solvent, such as paint thinner or benzene, strong acid or strong alkali to clean the surface of the E5C4, otherwise the surface of the E5C4 will become damaged.

ALL DIMENSIONS SHOWN ARE IN MILLIMETERS.

To convert millimeters into inches, multiply by 0.03937. To convert grams into ounces, multiply by 0.03527.

Cat. No. H82-E1-1 **In the interest of product improvement, specifications are subject to change without notice.**

OMRON Corporation

Systems Components Division
28th Fl., Crystal Tower Bldg.
1-2-27, Shiomi, Chuo-ku,
Osaka 540 Japan
Phone: 06-949-6012 Fax: 06-949-6021

Printed in Japan
0496-1M (0496) a