

POWER RELAY

1 POLE 16 A—SLIM POWER RELAY FTR-JR Series

RoHS compliant



■ FEATURES

- 1 Pole 16A slim relay with #187 Tab terminal
- Nominal Power: 530 mW (35% power reduction compared to VR Series)
- Cadmium free contacts
- Insulation distance: 9.5mm, Dielectric strength: 5K VAC Surge voltage 10K VAC
- JB: Tab terminal and contact terminal are connected electrically
JC: Tab terminal and contact terminal are not connected electrically
- UL Class B (130 °C), Flamability 94V-0
- SAFETY STANDARDS
UL, CSA, VDE
- RoHS compliant since date code: 0434R
Please see page 5 for more information



■ APPLICATIONS

- Microwave oven magnetron, and heater

■ ORDERING INFORMATION

[Example] $\frac{\text{FTR-JR}}{\text{(a)}} \frac{\text{J B}}{\text{(b)(c)}} \frac{\text{012}}{\text{(d)}} \frac{\text{W}}{\text{(e)}} \frac{\text{-**}}{\text{(f)}}$

(a)	Series Name	FTR-JR Series
(b)	Contact Arrangement	J : Tab terminal (#187)
(c)	Coil Type	B : 530 mW (TAB and PCB terminals connected) C : 530mW (TAB and PCB terminals unconnected)
(d)	Coil Nominal Voltage	012 : 12 VDC 018 : 18 VDC 024 : 24 VDC
(e)	Contact Material	W : Silver alloy
(f)	Custom Designation	Special Number

Note: The designation name is stamped on the top of the relay case as follows:
(Example: Designation ordered: FTR-JRJB012W
Stamp: JRJB012W

FTR-JR SERIES

■ COIL DATA CHART

MODEL	Nominal Voltage	Coil Resistance ($\pm 10\%$)	Must Operate Voltage	Must Release Voltage	Nominal Power
FTR-JR Series					
FTR-JRJ()012W	12 VDC	270 W	9.0 VDC	0.6 VDC	530 mW
FTR-JRJ()018W	18 VDC	610 W	13.5 VDC	0.9 VDC	530 mW
FTR-JRJ()024W	24 VDC	1,100 W	18.0 VDC	1.2 VDC	530 mW

Note: All values in the table are measured at 20°C.

■ SPECIFICATIONS

Item	FTR-JR Series		
Contact	Arrangement	1 Form A (SPST-NO)	
	Material	Silver alloy	
	Resistance (initial)	Maximum 100 m ohm (at 1A 6VDC)	
	Rating (resistive)	277VAC 16 A	
	Maximum Carrying Current	20A	
	Maximum Switching Rating	4,432VA	
	Maximum Switching Voltage	400 VAC	
	Maximum Switching Current	20A	
	Maximum Switching Load ^{*1}	5 VDC, 10 mA	
Coil	Nominal Power (at 20° C)	530mW	
	Operate Power (at 20° C)	300mW	
	Operating Temperature	-40° C to +85° C (no frost)	
Time Value	Operate Time (at nominal voltage)	Maximum 15 ms (excluding bounce time)	
	Release Time (at nominal voltage)	Maximum 10 ms (excluding bounce time)	
Life	Mechanical	2 x 10 ⁷ operations minimum	
	Electrical	Contact Rating	10 x 10 ⁴ operations minimum
Other	Vibration Resistance	Misoperation	10-55 Hz (double amplitude of 1.65mm)
		Endurance	10-55 Hz (double amplitude of 2.0mm)
	Shock Resistance	Misoperation	200m/s ² (11±1ms)
		Endurance	1,000m/s ² (6±1ms)
	Weight		Approximately 20g

*1 Minimum switching loads mentioned above are reference values. Please perform the confirmation test with the actual load before production since reference values may vary according to switching frequencies, environmental conditions and expected reliability levels.

FTR-JR SERIES

■ INSULATION

Item	FTR-JR	Note
Resistance (initial)	Minimum 1,000 MΩ	at 500 VDC
Dielectric Strength	open contacts	1,000 VAC (50/60 Hz) 1 min.
	coil and contacts	5,000 VAC (50/60 Hz) 1 min.
Surge Voltage (coil and contact)	10,000 V	1.2 x 50μs standard wave

■ SAFETY STANDARDS

Type	Compliance	Contact rating
UL	UL 508 E36314	Flammability: UL 94-V0 (plastics) 20A, 125VAC (resistive) 16A, 277VAC (resistive)
CSA	C22.2 No. 14 LR40304	
VDE	0435, 0631, 0700, 0860	

Complies with CQC

FTR-JR SERIES

CHARACTERISTIC DATA

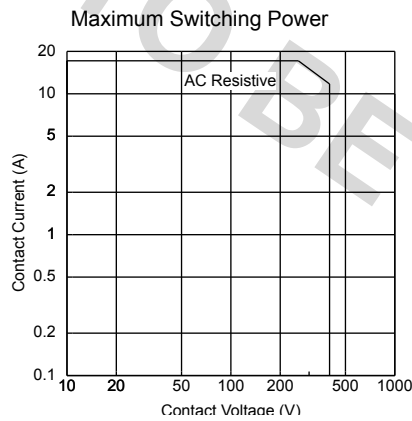
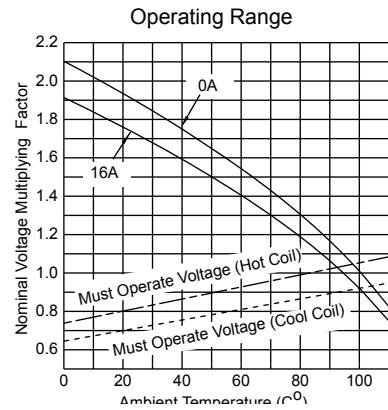
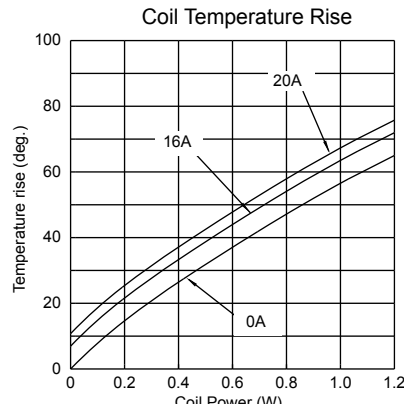
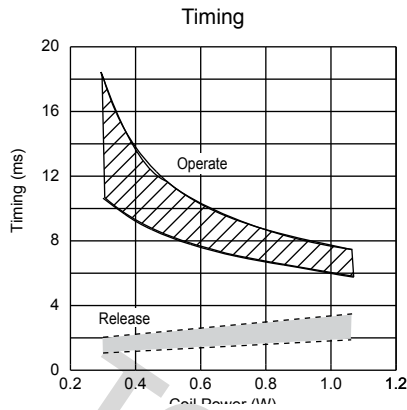

REFERENCE DATA

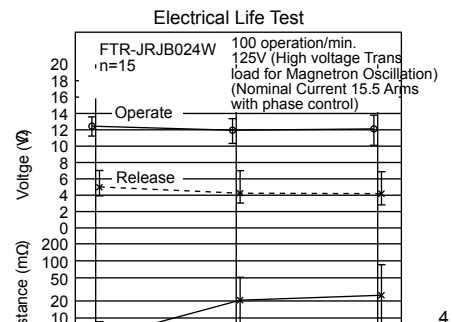
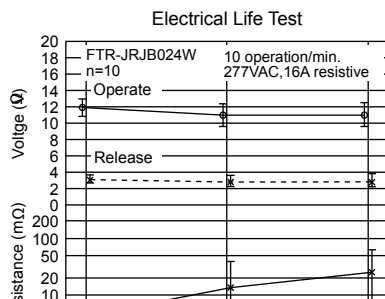
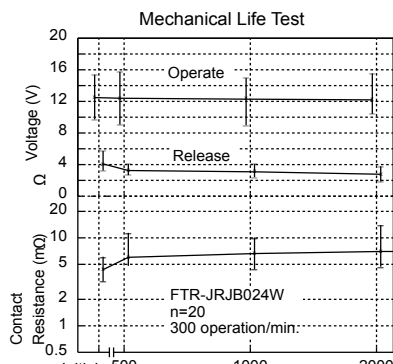
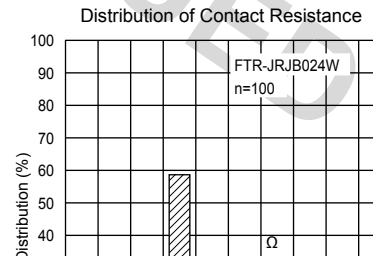
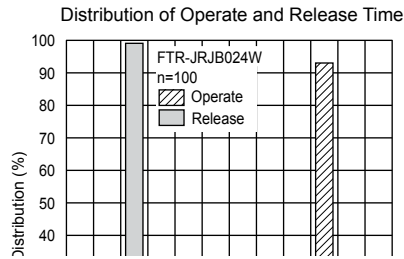
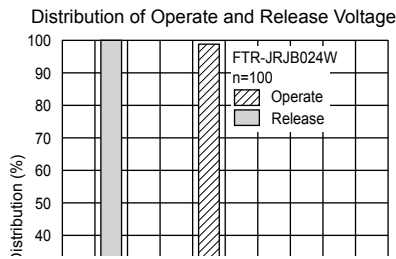

FTR-JR SERIES

■ DIMENSIONS

● Dimensions FTR-JB type

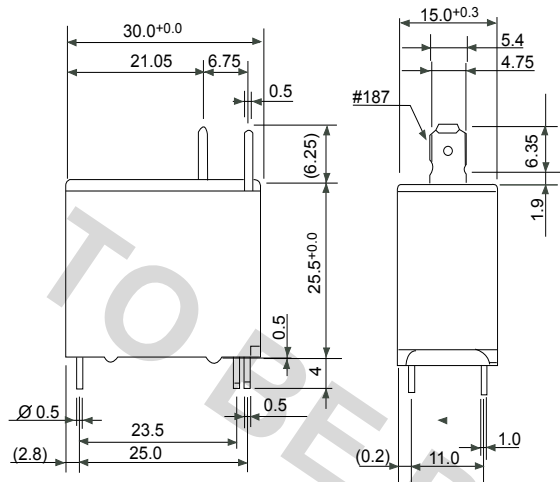

● Schematics (TOP VIEW)

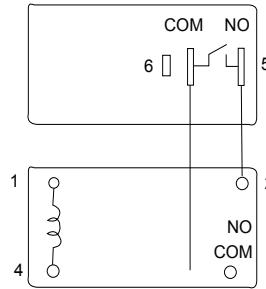

● PC board mounting hole layout (BOTTOM VIEW)

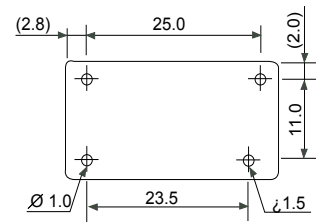

● Dimensions FTR-JC type

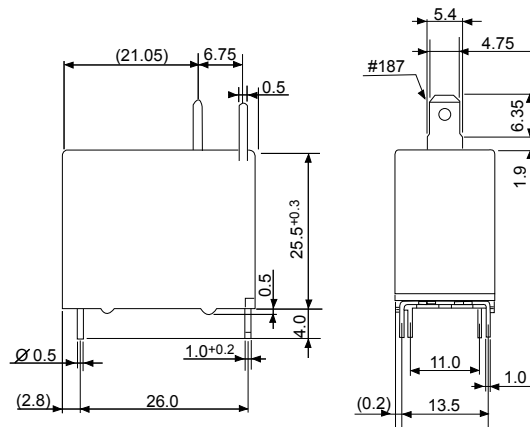

● Schematics (TOP VIEW)

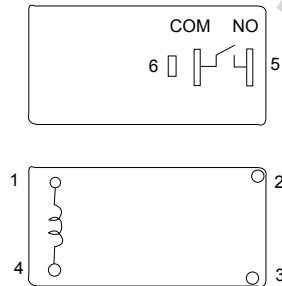

● PC board mounting hole layout (BOTTOM VIEW)

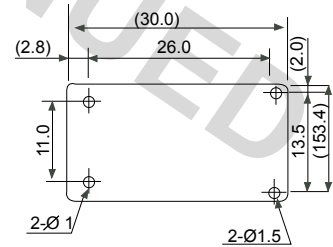

Unit: mm

RoHS Compliance and Lead Free Relay Information

1. General Information

- Relays produced after the specific date code that is indicated on each data sheet are lead-free now. All of our signal and power relays are lead-free. Please refer to Lead-Free Status Info. (<http://www.fujitsu.com/us/downloads/MICRO/fcai/relays/lead-free-letter.pdf>)
- Lead free solder paste currently used in relays is Sn-3.0Ag-0.5Cu.
- All signal and power relays also comply with RoHS. Please refer to individual data sheets. Relays that are RoHS compliant do not contain the 5 hazardous materials that are restricted by RoHS directive (lead, mercury, chromium IV, PBB, PBDE).
- It has been verified that using lead-free relays in lead assembly process will not cause any problems (compatible).
- "LF" is marked on each outer and inner carton. (No marking on individual relays).
- To avoid leaded relays (for lead-free sample, etc.) please consult with area sales office.
- We will ship leaded relays as long as the leaded relay inventory exists.

Note: Cadmium was exempted from RoHS on October 21, 2005. (Amendment to Directive 2002/95/EC)

2. Recommended Lead Free Solder Profile

- Recommended solder paste Sn-3.0Ag-0.5Cu.

Reflow Solder condition

Flow Solder condition:

Pre-heating: maximum 120°C
Soldering: dip within 5 sec. at
260°C solder bath

Solder by Soldering Iron:

Soldering Iron
Temperature: maximum 360°C
Duration: maximum 3 sec.

We highly recommend that you confirm your actual solder conditions

3. Moisture Sensitivity

- Moisture Sensitivity Level standard is not applicable to electromechanical relays.

4. Tin Whisker

- Dipped SnAgCu solder is known as low risk tin whisker. No considerable length whisker was found by our in house test.

Fujitsu Components International Headquarter Offices

Japan

Fujitsu Component Limited
Gotanda-Chuo Building
3-5, Higashigotanda 2-chome, Shinagawa-ku
Tokyo 141, Japan
Tel: (81-3) 5449-7010
Fax: (81-3) 5449-2626
Email: promothq@ft.ed.fujitsu.com
Web: www.fcl.fujitsu.com

North and South America

Fujitsu Components America, Inc.
250 E. Caribbean Drive
Sunnyvale, CA 94089 U.S.A.
Tel: (1-408) 745-4900
Fax: (1-408) 745-4970
Email: components@us.fujitsu.com
Web: <http://www.fujitsu.com/us/services/edevices/components/>

Europe

Fujitsu Components Europe B.V.
Diamantlaan 25
2132 WV Hoofddorp
Netherlands
Tel: (31-23) 5560910
Fax: (31-23) 5560950
Email: info@fceu.fujitsu.com
Web: emea.fujitsu.com/components/

Asia Pacific

Fujitsu Components Asia Ltd.
102E Pasir Panjang Road
#01-01 Citilink Warehouse Complex
Singapore 118529
Tel: (65) 6375-8560
Fax: (65) 6273-3021
Email: fcal@fcal.fujitsu.com
Web: <http://www.fujitsu.com/sg/services/micro/components/>

©2009 Fujitsu Components America, Inc. All rights reserved. All trademarks or registered trademarks are the property of their respective owners.

Fujitsu Components America or its affiliates do not warrant that the content of datasheet is error free. In a continuing effort to improve our products Fujitsu Components America, Inc. or its affiliates reserve the right to change specifications/datasheets without prior notice.
Rev. June 30, 2009.