

DATA SHEET

TX9.7/4.8/3.2
Alloy powder toroids

New data

2008 Sep 01

Alloy powder toroids

TX9.7/4.8/3.2

RING CORES (TOROIDS)

Effective core parameters

SYMBOL	PARAMETER	VALUE	UNIT
$\Sigma(I/A)$	core factor (C1)	2.90	mm ⁻¹
V_e	effective volume	164	mm ³
l_e	effective length	21.8	mm
A_e	effective area	7.52	mm ²
m	mass of core (for μ_i 125)	MPP	1.40 g
		Sendust	1.01 g
		High-Flux	1.30 g

Coating

The cores are coated with epoxy. The colour is black (Sendust), grey (MPP) or khaki (High-Flux). Maximum operating temperature is 200 °C. Parylene coating is also available (transparent, maximum operating temperature 130 °C).

Isolation voltage

AC isolation voltage : 1000 V (Parylene : 750 V).
Contacts are applied on the edge of the ring core, which is also the critical point for the winding operation.

Ring core data - Note 1. Mechanical dimensions : OD ≤ 10.29, ID ≥ 4.27, H ≤ 3.81

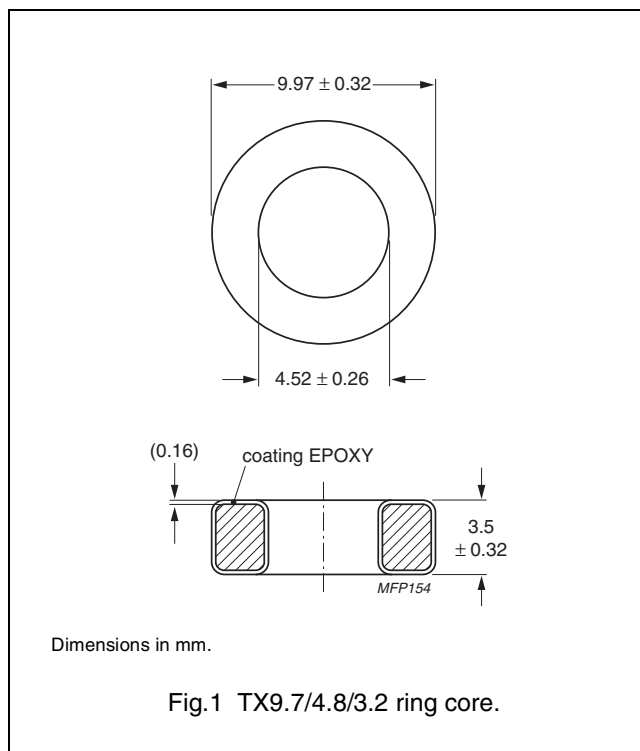

GRADE	A _L (nH)	μ_i	B (mT) at	CORE LOSS (W) at	TYPE NUMBER
			H = 100 kA/m; f = 10 kHz; T = 25 °C	f = 100 kHz; \hat{B} = 100 mT; T = 25 °C	
MPP	6 ± 8 %	14	≥ 640	0.246	TX9.7/3.2-M2-A6
	11 ± 8 %	26	≥ 700	0.197	TX9.7/3.2-M2-A11
	25 ± 8 %	60	≥ 760	0.123	TX9.7/3.2-M2-A25
	53 ± 8 %	125	≥ 800	0.123	TX9.7/3.2-M2-A53
	63 ± 8 %	147	≥ 800	0.131	TX9.7/3.2-M2-A63
	68 ± 8 %	160	≥ 800	0.131	TX9.7/3.2-M2-A68
	74 ± 8 %	173	≥ 800	0.131	TX9.7/3.2-M2-A74
	84 ± 8 %	200	≥ 800	0.246	TX9.7/3.2-M2-A84
Sendust ⁽¹⁾	128 ± 8 %	300	≥ 800	0.246	TX9.7/3.2-M2-A128
	25 ± 12 %	60	≥ 1030	0.140	TX9.7/3.2-S7-A25-MC
	32 ± 12 %	75	≥ 1040	0.140	TX9.7/3.2-S7-A32-MC
	38 ± 12 %	90	≥ 1050	0.140	TX9.7/3.2-S7-A38-MC
High-Flux	53 ± 12 %	125	≥ 1060	0.140	TX9.7/3.2-S7-A53-MC
	6 ± 8 %	14	≥ 890	0.410	TX9.7/3.2-H2-A6
	11 ± 8 %	26	≥ 980	0.328	TX9.7/3.2-H2-A11
	25 ± 8 %	60	≥ 1280	0.295	TX9.7/3.2-H2-A25
	53 ± 8 %	125	≥ 1370	0.328	TX9.7/3.2-H2-A53
	63 ± 8 %	147	≥ 1385	0.361	TX9.7/3.2-H2-A63
	68 ± 8 %	160	≥ 1400	0.574	TX9.7/3.2-H2-A68

Alloy powder toroids

TX9.7/4.8/3.2

DATA SHEET STATUS DEFINITIONS

DATA SHEET STATUS	PRODUCT STATUS	DEFINITIONS
Preliminary specification	Development	This data sheet contains preliminary data. Ferroxcube reserves the right to make changes at any time without notice in order to improve design and supply the best possible product.
Product specification	Production	This data sheet contains final specifications. Ferroxcube reserves the right to make changes at any time without notice in order to improve design and supply the best possible product.

DISCLAIMER

Life support applications — These products are not designed for use in life support appliances, devices, or systems where malfunction of these products can reasonably be expected to result in personal injury. Ferroxcube customers using or selling these products for use in such applications do so at their own risk and agree to fully indemnify Ferroxcube for any damages resulting from such application.

PRODUCT STATUS DEFINITIONS

STATUS	INDICATION	DEFINITION
Prototype		These are products that have been made as development samples for the purposes of technical evaluation only. The data for these types is provisional and is subject to change.
Design-in		These products are recommended for new designs.
Preferred		These products are recommended for use in current designs and are available via our sales channels.
Support		These products are not recommended for new designs and may not be available through all of our sales channels. Customers are advised to check for availability.