

## Series CF Compact Flash Card Slim Type I (without Ejector)

### Specifications

Insulation Resistance: 1000MΩ at 500V DC  
 Withstanding Voltage: 500Vrms  
 Current Rating: 1A AC/DC max.  
 Contact Resistance: 40mΩ max. at 20mV max.

Operating Temp. Range: -55°C to +85°C  
 Reflow Solder Temp.: 220°C min. / 60 sec., 260°C peak  
 Mating Cycles: 10,000 times

### Materials and Finish

Insulator: LCP, glass filled (UL94V-0)  
 SMT Metal: Brass, pure Sn  
 Contacts: Brass  
 Plating: Contacts - Gold (15μ") over Nickel (40μ")  
 Solder Tails - pure Sn

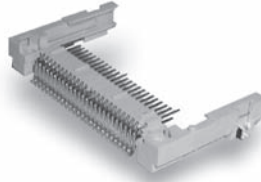

### Featur

- Adapter for Compact Flash Card type I and II
- Available for top and bottom PCB mounting
- Without cap for pick and place

### Outline Dimensions

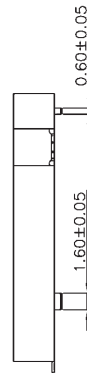
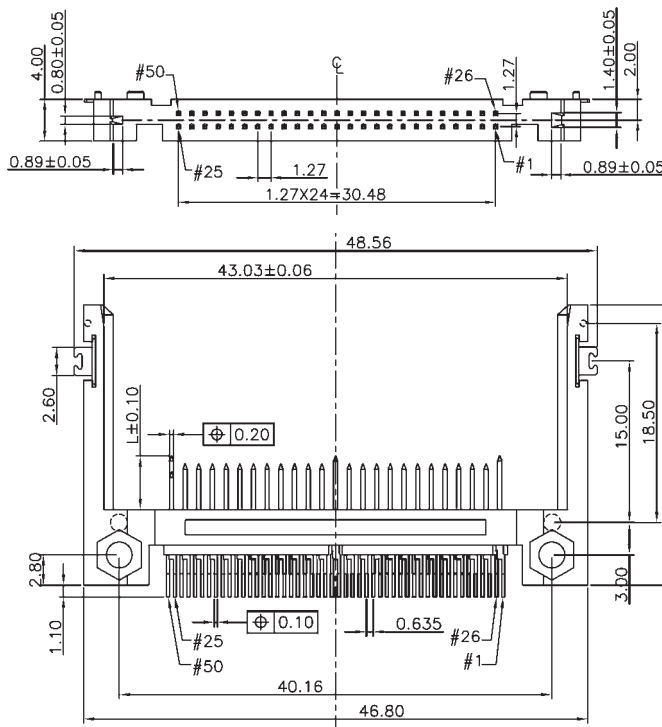

#### Interface Dim. L (Length)

Power	= 5.00mm	Pin# 1, 13, 38, 50
General	= 4.25mm	all other pins
Detect	= 3.50mm	Pin# 25, 26

### Recommended PCB Layout

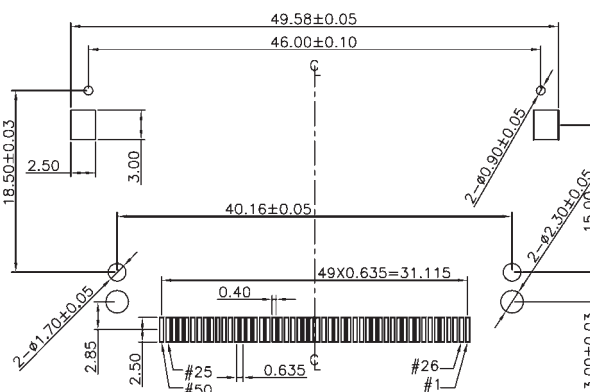

### Part Number (Details)

CF 050 P1S - 0 0 3 - 0 0 DS \*

Series	CF
No. of Contacts	050
Stand-off Height	0 = Without
PCB Mounting Type	0 = Top
90° SMT	
Ejector	0 = Without
Fixing Method	0 = SMT Fixing
Plating Area	Contacts: Gold 15μ" over 40μ" Nickel Solder Tails: 100μ" Tin over 40μ" Nickel
Lock Option	0 = Without 1 = Nut Mounted

Compact Flash Card Reader

### Specifications

Insulation Resistance: 1000MΩ at 500V DC  
 Withstanding Voltage: 500Vrms  
 Current Rating: 1A AC/DC max.  
 Contact Resistance: 40mΩ max. at 20mV max.  
 Operating Temp. Range: -55°C to +85°C  
 Reflow Solder Temp.: 220°C min. / 60 sec., 260°C peak  
 Mating Cycles: 10,000 times

### Materials and Finish

Insulator: LCP, glass filled (UL94V-0)  
 SMT Metal: Brass, pure Sn  
 Contacts: Brass  
 Plating: Contacts - Gold (15μ") over Nickel (40μ")  
 Solder Tails - pure Sn

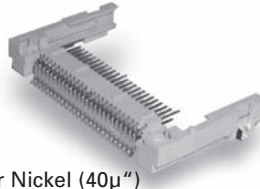

### Features

- Adapter for Compact Flash Card Type I
- Available for top and bottom PCB mounting
- Without cap for pick and place

### Part Number (Details)

CF 050 P1S - 0 1 3 - 0 0 DS \*

Series	CF
No. of Contacts	050
Stand-off Height	0 = Without
PCB Mounting Type	1 = Bottom (Reverse)
	3 = 90° SMT
Ejector:	0 = Without
Fixing Method:	0 = SMT Fixing
Plating Area:	
Contacts:	Gold 15μ" over 40μ" Nickel
Solder Tails:	100μ" Tin over 40μ" Nickel
Lock Option:	0 = Without 1 = Nut Mounted

### Outline Dimensions

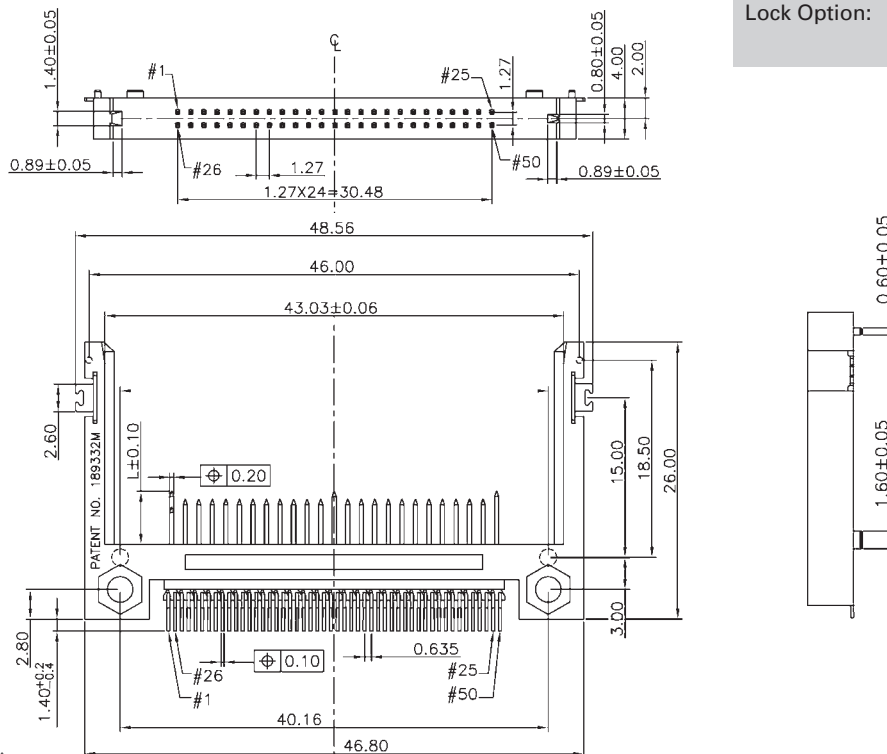

Interface Dim. L (Length)	
Power	= 5.00mm   Pin# 1, 13, 38, 50
General	= 4.25mm   all other pins
Detect	= 3.50mm   Pin# 25, 26

### Recommended PCB Layout

