

1.5MHz, 1A Synchronous Step-Down Converter with Soft Start

DESCRIPTION

The EUP3010/A is a constant frequency, current mode, PWM step-down converter. The device integrates a main switch and a synchronous rectifier for high efficiency. The 2.5V to 5.5V input voltage range makes the EUP3010/A ideal for powering portable equipment that runs from a single cell Lithium-Ion (Li+) battery or 3-cell NiMH/ NiCd batteries. The output voltage can be regulated as low as 0.6V. The EUP3010/A supports up to 1A load current and can also run at 100% duty cycle for low dropout applications, extending battery life in portable systems.

Switching frequency is internally set at 1.5MHz, allowing the use of small surface mount inductors and capacitors. The internal synchronous switch increases efficiency while eliminates the need for an external Schottky diode. The EUP3010/A is available in an adjustable output or fixed output 1.2V, 1.8V and 3.3V.

FEATURES

- High Efficiency up to 96%
- 1.5MHz Constant Switching Frequency
- 1A Available Load Current
- 270μA Typical Quiescent Current
- 2.5V to 5.5V Input Voltage Range
- Adjustable Output Voltage as Low as 0.6V
- 100% Duty Cycle Low Dropout Operation
- No Schottky Diode Required
- Short Circuit and Thermal Protection
- Excellent Line and Load Transient Response
- < 1μA Shutdown Current
- Soft Start Function
- Over Voltage Protection
- Available in 1.2V, 1.8V, 3.3V Fixed Output or Adjustable Output Versions
- Available in 2mm×2mm TDFN-6 and 3mm×3mm TQFN-16L Package
- RoHS Compliant and 100% Lead(Pb)-Free

APPLICATIONS

- Cellular and Smart Phones
- Portable Media Players/ MP3 Players
- Digital Still and Video Cameras
- Portable Instruments
- WLAN PC Cards

Typical Application Circuit

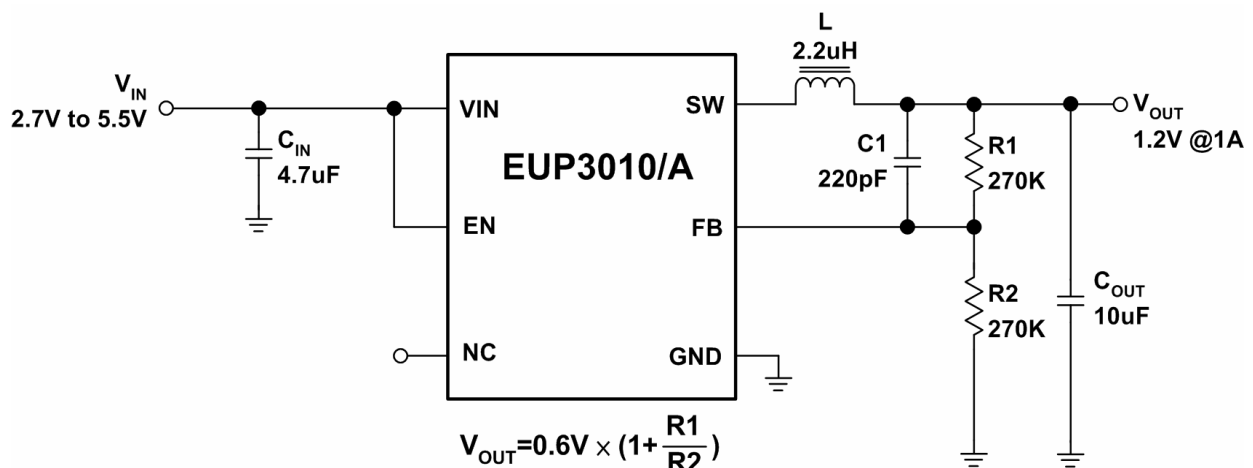

Figure 1. Adjustable Output Regulators

Typical Application Circuit (continued)

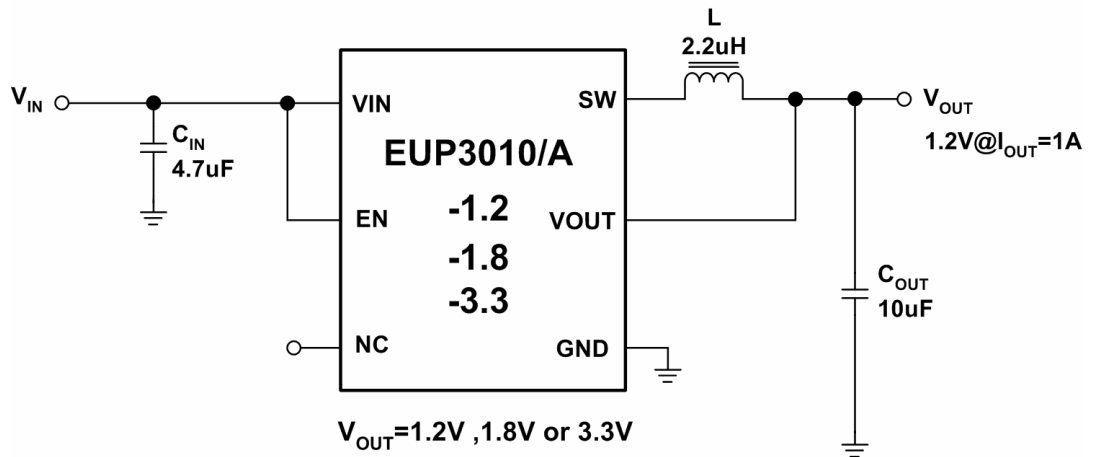

Figure 2. Fixed Output Regulators

Pin Configurations

Package Type	Pin Configurations	Package Type	Pin Configurations
EUP3010 TDFN-6 ADJ Voltage		EUP3010 TDFN-6 Fixed Voltage	
EUP3010A TQFN-16 ADJ Voltage		EUP3010A TQFN-16 Fixed Voltage	

EUP3010/A Pin Description

PIN	EUP3010 TDFN-6	EUP3010A TQFN-16	DESCRIPTION
NC	1	6, 8, 16	No Internal Connect(Floating or Connecting to GND).
EN	2	7	Chip Enable Pin. Forcing this pin above 1.5V enables the part. Forcing this pin below 0.3V shuts down the device. Do not leave EN floating.
VIN	3	9, 10, 11, 12	Supply Voltage Pin.
SW	4	13, 14, 15	Switch Node Connection to Inductor. This pin connects to the drains of the internal main and synchronous power MOSFET switches.
GND	5	1, 2, 3, 5	Common Ground.
FB/VOUT	6	4	Feedback / Output Voltage Pin .

EUP3010/A Functional Block Diagram

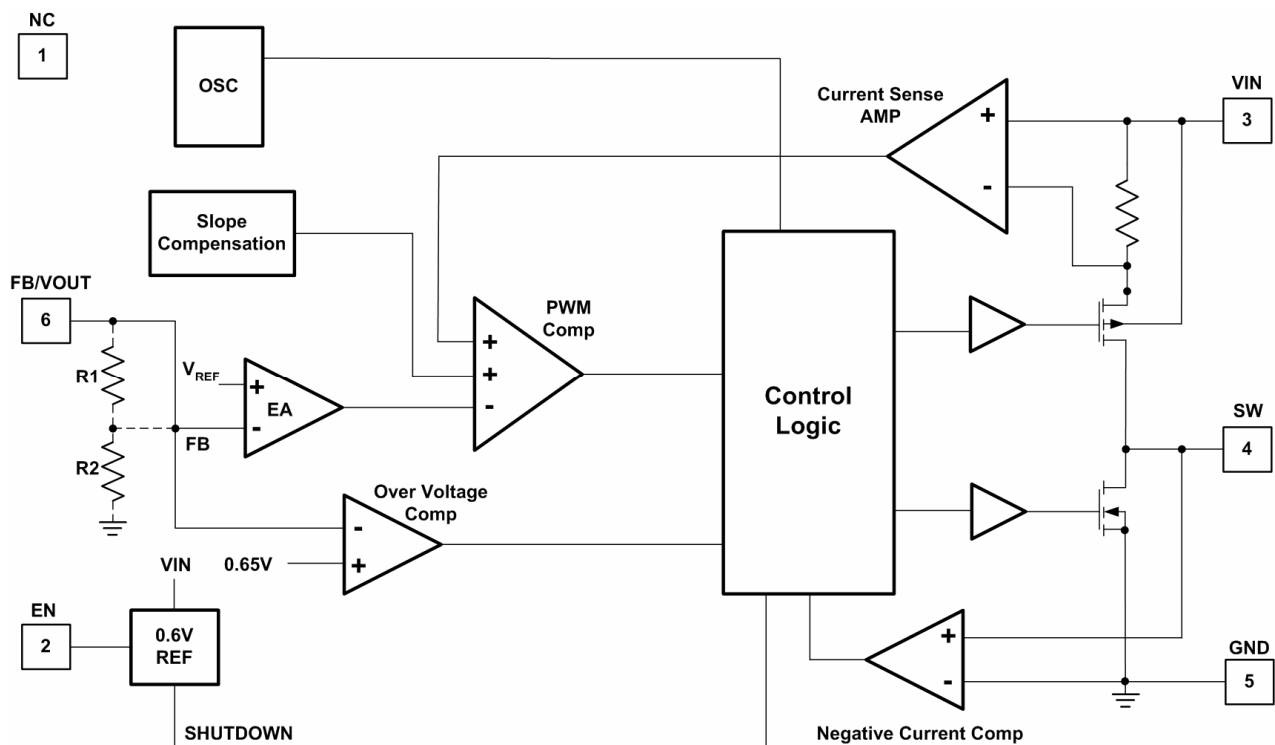

Ordering Information

Order Number	Package Type	Marking	Operating Temperature Range
EUP3010-12JIR1	TDFN-6	xxx g T	-40 °C to +85°C
EUP3010-18JIR1	TDFN-6	xxx g D	-40 °C to +85°C
EUP3010-33JIR1	TDFN-6	xxx g H	-40 °C to +85°C
EUP3010JIR1	TDFN-6	xxx g A	-40 °C to +85°C
EUP3010A-12JIR1	TQFN-16	xxxxx 3010A 1T	-40 °C to +85°C
EUP3010A-18JIR1	TQFN-16	xxxxx 3010A 1D	-40 °C to +85°C
EUP3010A-33JIR1	TQFN-16	xxxxx 3010A 1H	-40 °C to +85°C
EUP3010AJIR1	TQFN-16	xxxxx 3010A 1A	-40 °C to +85°C

EUP3010/A-

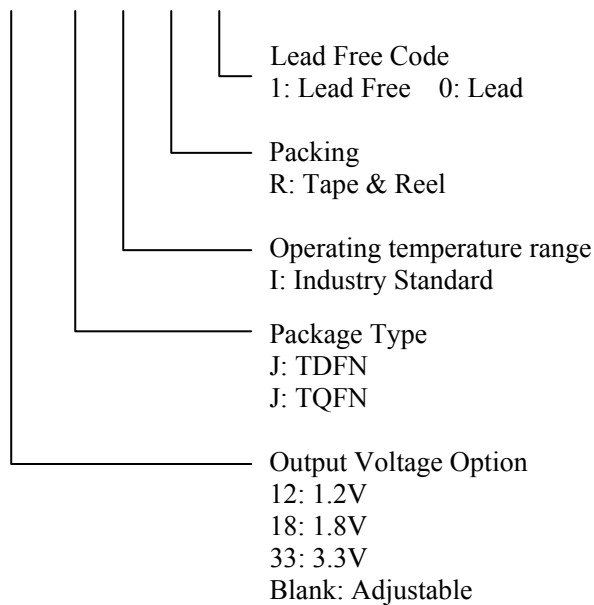

Absolute Maximum Ratings (1)

- Input Supply Voltage V_{IN} ----- -0.3V to 6V
- EN, V_{FB} Voltages ----- -0.3V to $V_{IN} + 0.3V$
- P-Channel Switch Source Current (DC) ----- 1.2A
- N-Channel Switch Sink Current (DC) ----- 1.2A
- Peak SW Sink and Source Current ----- 1.8A
- Junction Temperature ----- 125°C
- Storage Temperature ----- -65°C to +150°C
- Lead Temp (Soldering, 10sec) ----- 260°C

Recommend Operating Conditions (2)

- Supply Voltage (V_{IN}) ----- 2.5V to 5.5V
- Operating Temperature Range ----- -40°C to +85°C

Note (1): Stress beyond those listed under “Absolute Maximum Ratings” may damage the device.

Note (2): The device is not guaranteed to function outside the recommended operating conditions.

Electrical Characteristics

Unless otherwise specified, $T_A = +25^\circ\text{C}$, $V_{IN} = 3.6V$.

Symbol	Parameter	Conditions	EUP3010/A			Unit
			Min	Typ	Max.	
V_{IN}	Input Voltage Range		2.5		5.5	V
I_{FB}	Feedback Current			±30		nA
I_Q	Quiescent Current	$V_{FB} = 0.5V$ or $V_{OUT} = 90\%$, SW Open		270	370	μA
I_{SHDN}	Shutdown Current	$V_{EN} = 0V$, $V_{IN} = 4.2V$			1	μA
I_{PK}	Peak Inductor Current	$V_{IN} = 3V$, $V_{FB} = 0.5V$ or $V_{OUT} = 90\%$	1.2	1.5		A
V_{FB}	Regulated Feedback Voltage	(Note 3) ADJ Version	0.588	0.6	0.612	V
V_{OUT}	Regulated Output Voltage	$I_{OUT} = 200mA$ Fix Version $V_{OUT} = 1.2V, 1.8V, 3.3V$	-3		3	%
ΔV_{OUT}	Output Voltage Line Regulation	$V_{IN} = 2.5V$ to $5.5V$, $I_{LOAD} = 0$		0.25	0.4	%/V
ΔV_{FB}	Reference Voltage Line Regulation	$V_{IN} = 2.5V$ to $5.5V$		0.25	0.4	%/V
$V_{LOADREG}$	Output Voltage Load Regulation	$I_{LOAD} = 0mA$ to $1A$		0.5		%
f_{OSC}	Oscillator Frequency	$V_{FB} = 0.6V$ or $V_{OUT} = 100\%$	1.2	1.5	1.8	MHz
		$V_{FB} = 0V$ or $V_{OUT} = 0V$		700		kHz
R_{PFET}	$R_{DS(ON)}$ of P-Channel FET	$I_{SW} = 200mA$		0.28	0.4	Ω
R_{NFET}	$R_{DS(ON)}$ of N-Channel FET	$I_{SW} = -200mA$		0.30	0.4	Ω
I_{LSW}	SW Leakage Current	$V_{EN} = 0V$, $V_{SW} = 0V$ or $5V$, $V_{IN} = 5V$			±1	μA
V_{EN}	EN Threshold		0.3	1.0	1.5	V
I_{EN}	EN Leakage Current				1	μA

Note (3): The EUP3010/A is tested in a proprietary test mode that connects FB to the output of the error amplifier.

Typical Operating Characteristics

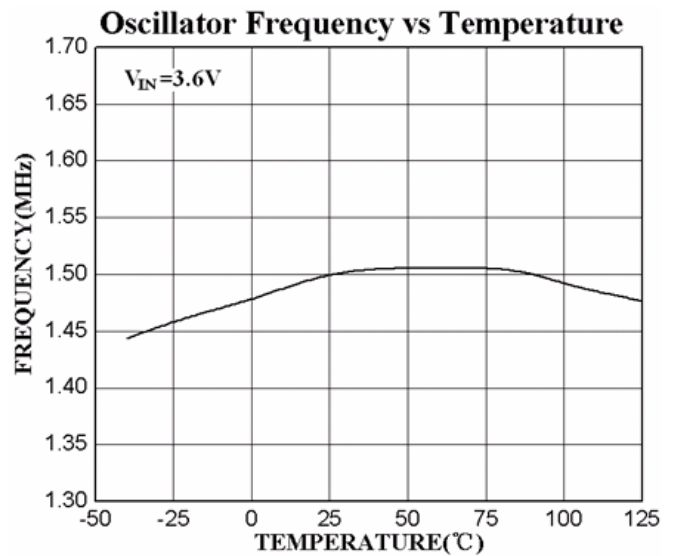
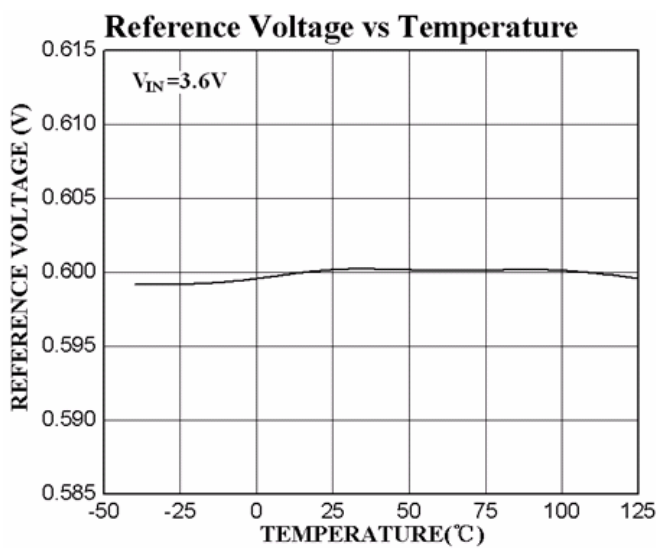
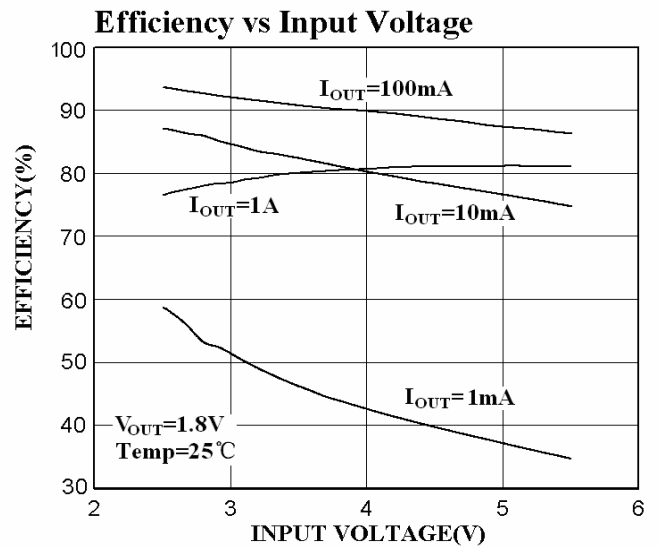
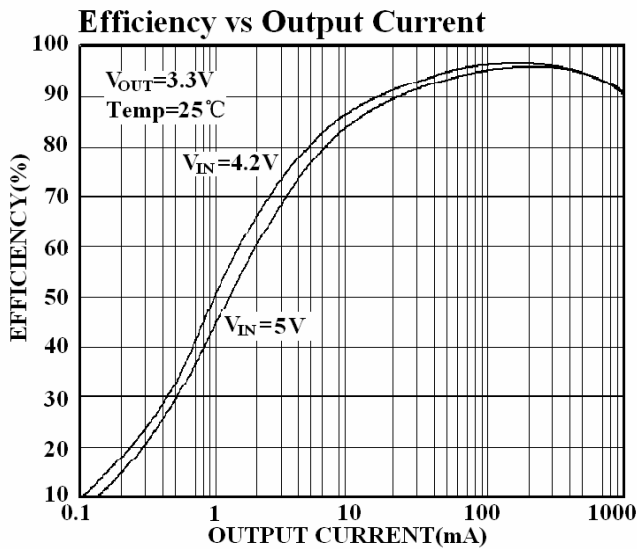
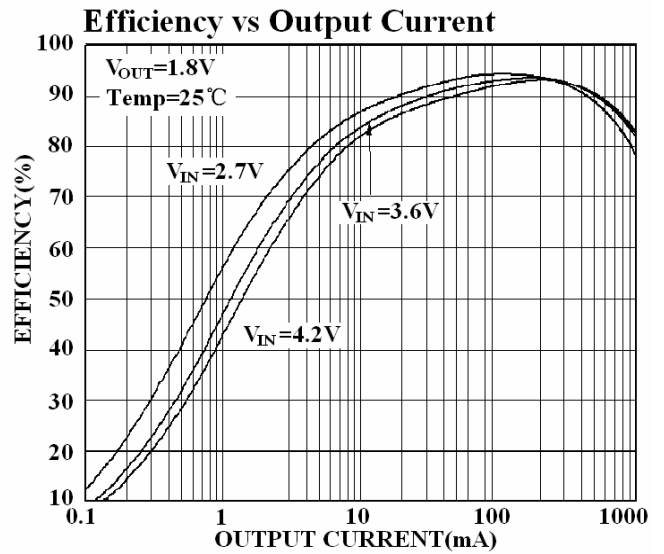
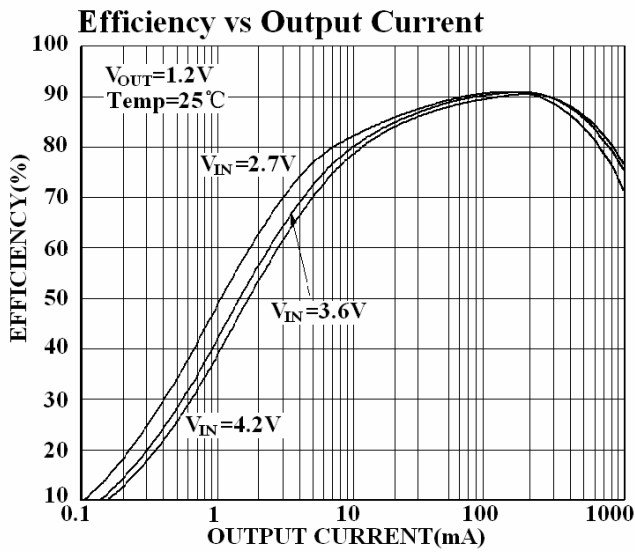

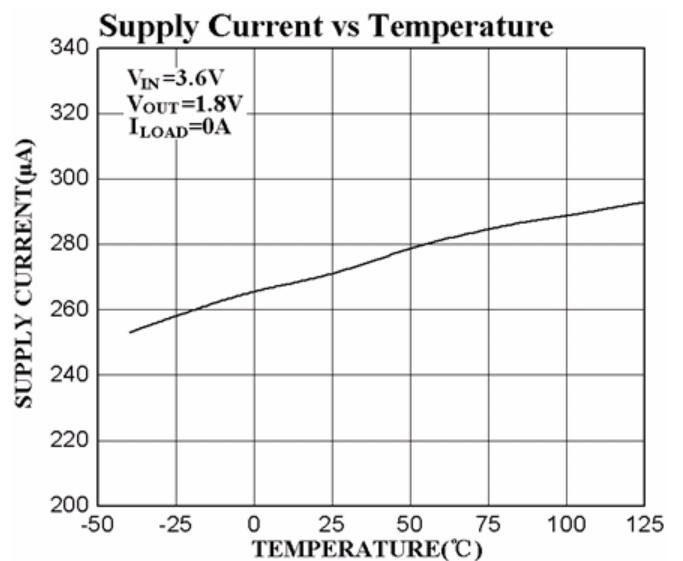
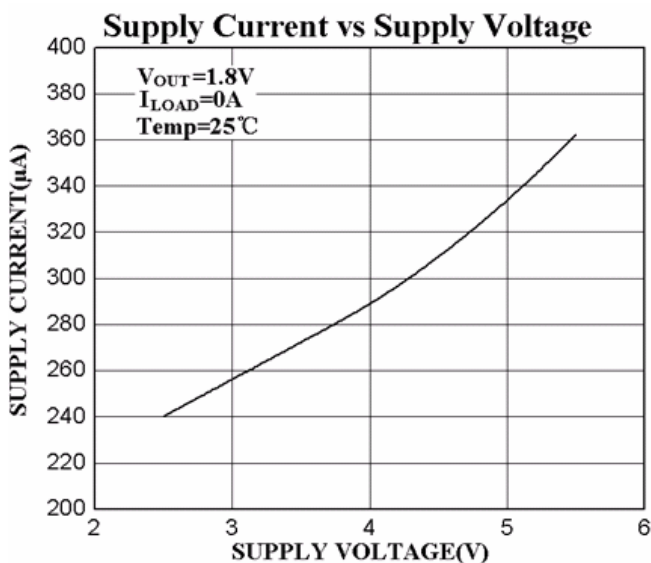
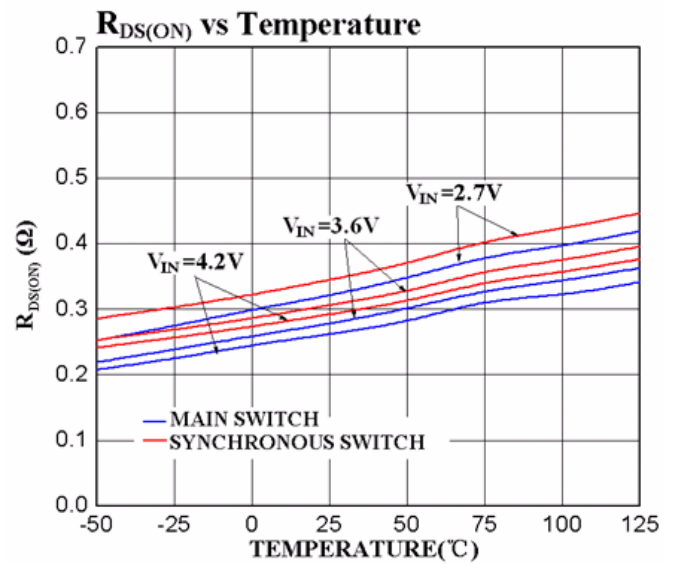
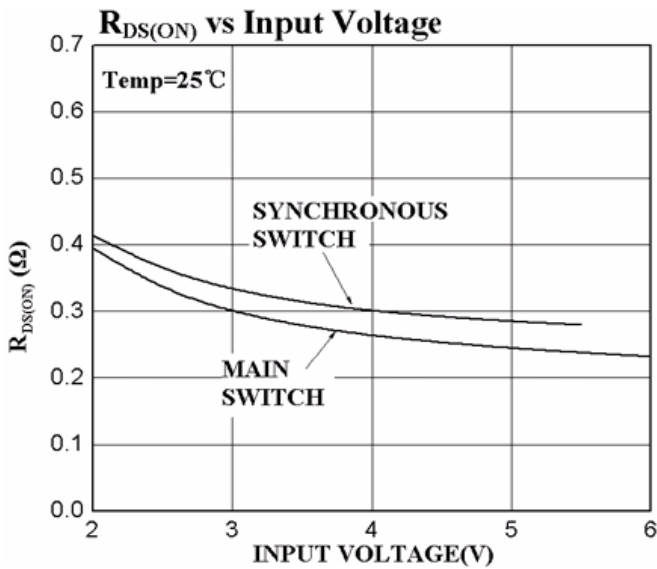
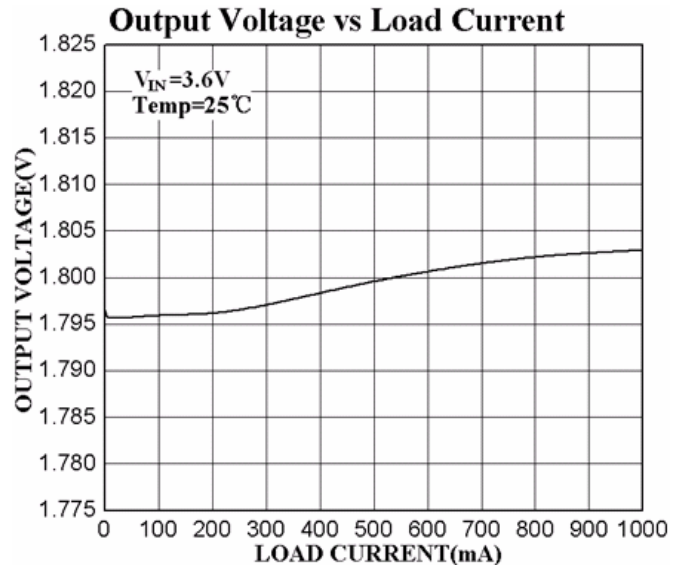
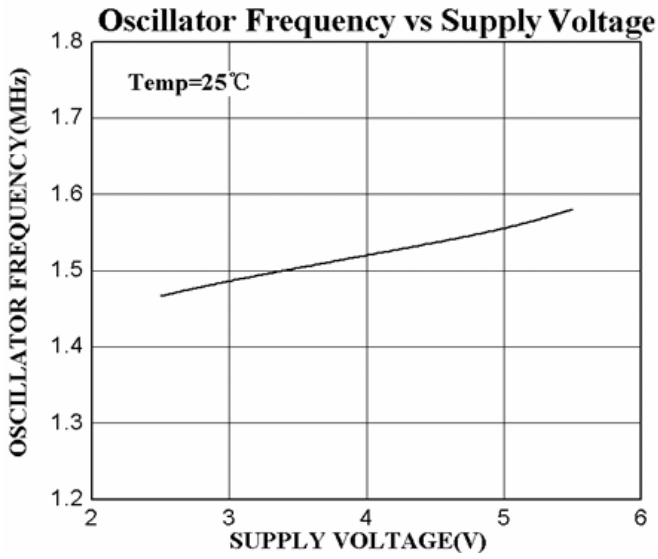

Discontinuous Operation

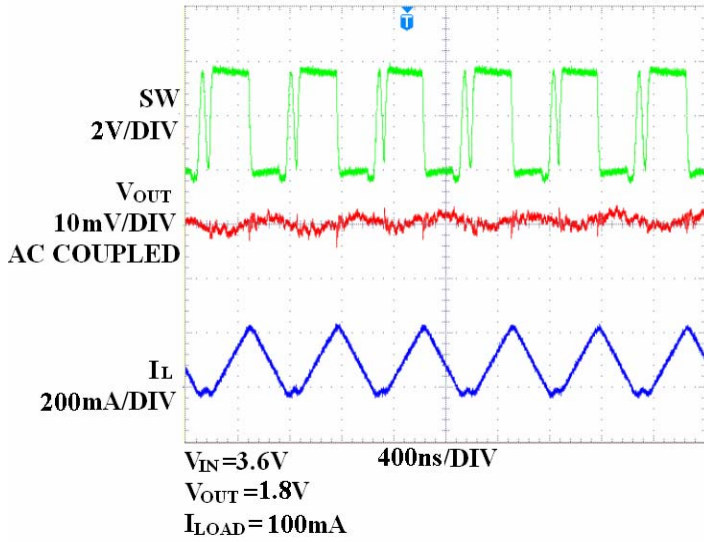

Normal Operation

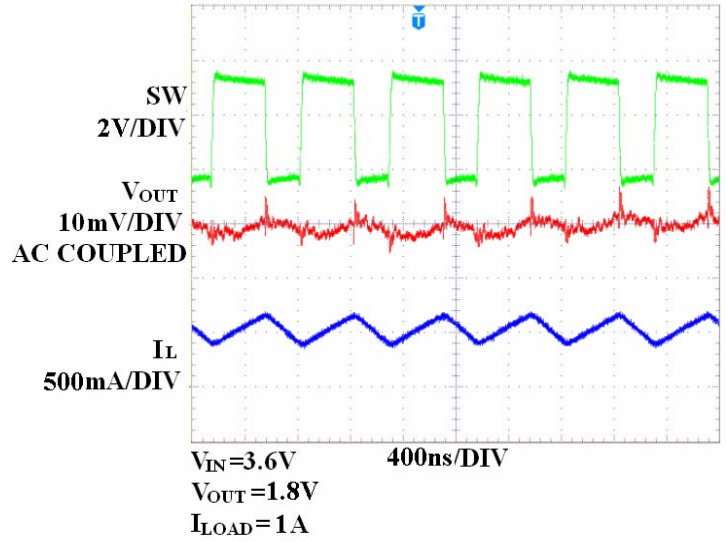

Start-Up from Shutdown

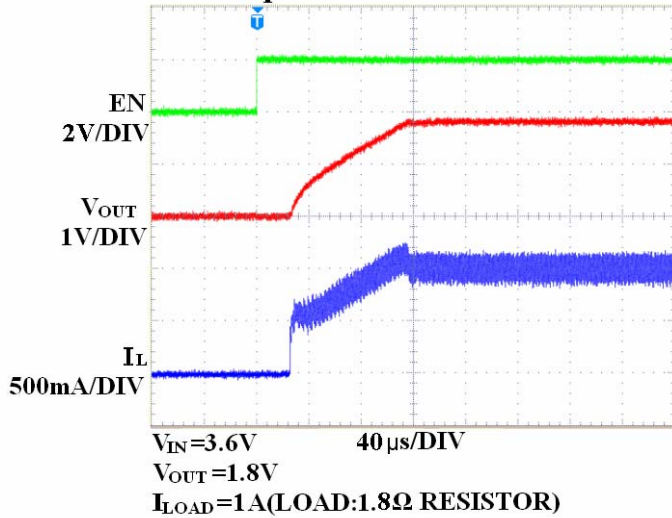

Load Step

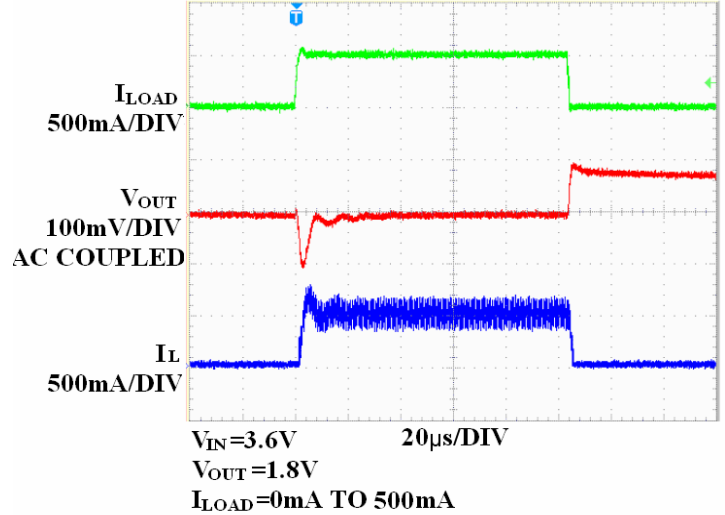

Load Step

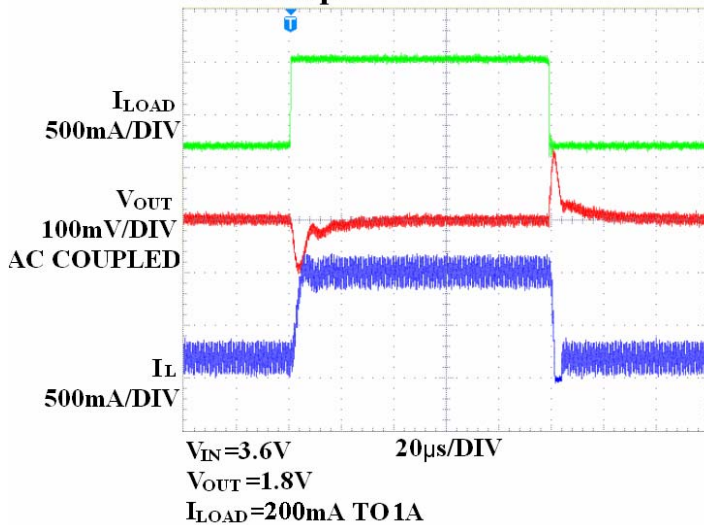

Load Step

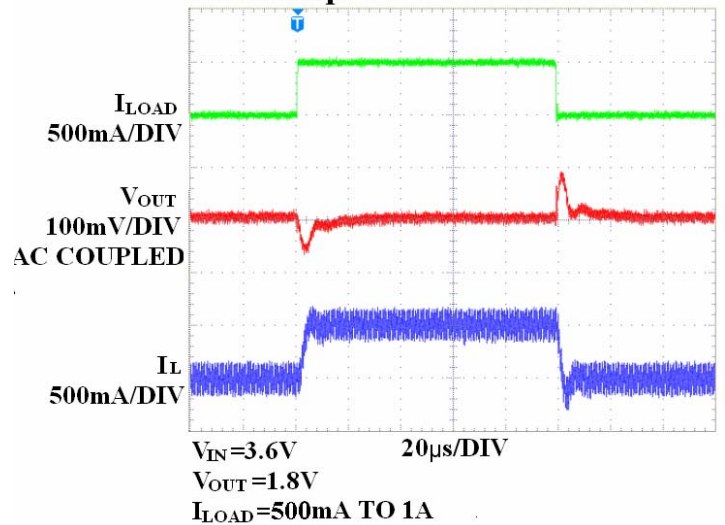

Application Information

Main Control Loop

The EUP3010/A uses a slope-compensated constant frequency, current mode architecture. Both the main (P-Channel MOSFET) and synchronous (N-channel MOSFET) switches are internal. During normal operation, the EUP3010/A regulates output voltage by switching at a constant frequency and then modulating the power transferred to the load each cycle using PWM comparator. The duty cycle is controlled by three weighted differential signals: the output of error amplifier, the main switch sense voltage and the slope-compensation ramp. It modulates output power by adjusting the inductor-peak current during the first half of each cycle. An N-channel, synchronous switch turns on during the second half of each cycle (off time). When the inductor current starts to reverse or when the PWM reaches the end of the oscillator period, the synchronous switch turns off. This keeps excess current from flowing backward through the inductor, from the output capacitor to GND, or through the main and synchronous switch to GND.

Inductor Selection

The output inductor is selected to limit the ripple current to some predetermined value, typically 20%~40% of the full load current at the maximum input voltage. Large value inductors lower ripple currents. Higher V_{IN} or V_{OUT} also increases the ripple current as shown in equation. A reasonable starting point for setting ripple current is $\Delta I_L=400\text{mA}$ (40% of 1A).

$$\Delta I_L = \frac{1}{(f)(L)} \times V_{OUT} \times \left(1 - \frac{V_{OUT}}{V_{IN}} \right)$$

The DC current rating of the inductor should be at least equal to the maximum load current plus half the ripple current to prevent core saturation. Thus, a 1.2A rated inductor should be enough for most applications (1A+200mA). For better efficiency, choose a low DC-resistance inductor.

C_{IN} and C_{OUT} Selection

In continuous mode, the source current of the top MOSFET is a square wave of duty cycle V_{OUT}/V_{IN} . The primary function of the input capacitor is to provide a low impedance loop for the edges of pulsed current drawn by the EUP3010/A. A low ESR input capacitor sized for the maximum RMS current must be used. The size required will vary depending on the load, output voltage and input voltage source impedance characteristics. A typical value is around 4.7 μF .

The input capacitor RMS current varies with the input voltage and the output voltage. The equation for the maximum RMS current in the input capacitor is:

$$I_{RMS} = I_O \times \sqrt{\frac{V_O}{V_{IN}} \times \left(1 - \frac{V_O}{V_{IN}} \right)}$$

The output capacitor C_{OUT} has a strong effect on loop stability.

The selection of C_{OUT} is driven by the required effective series resistance (ESR).

ESR is a direct function of the volume of the capacitor, that is, physically larger capacitors have lower ESR. Once the ESR requirement for C_{OUT} has been met, the RMS current rating generally far exceeds the $I_{RIPPLE(P-P)}$ requirement. The output ripple ΔV_{OUT} is determined by:

$$\Delta V_{OUT} \cong \Delta I_L \times \left(\text{ESR} + \frac{1}{8fC_{OUT}} \right)$$

When choosing the input and output ceramic capacitors, choose the X5R or X7R dielectric formulations. These dielectrics have the best temperature and voltage characteristics of all the ceramics for a given value and size.

Output Voltage Programming

The output voltage is set by a resistive divider according to the following formula:

$$V_{OUT} = 0.6V \times \left(1 + \frac{R1}{R2} \right)$$

For adjustable voltage package, the external resistive divider is connected to the output, allowing remote voltage sensing as shown in below figure.

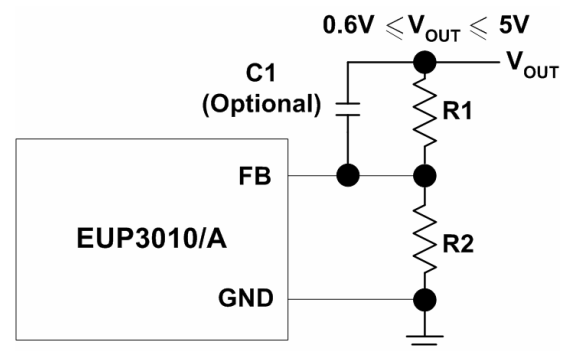

$C1$ is a feedforward cap which can speed loop response and reduce output ripple during load transient. Choose $C1$ value between 220pF and 680pF for most applications.

Thermal Considerations

To avoid the EUP3010/A from exceeding the maximum junction temperature, the user will need to do a thermal analysis. The goal of the thermal analysis is to determine whether the operating conditions exceed the maximum junction temperature of the part. The temperature rise is given by:

$$T_R = (P_D)(\theta_{JA})$$

Where $P_D = I_{LOAD}^2 \times R_{DS(ON)}$ is the power dissipated by the regulator ; θ_{JA} is the thermal resistance from the junction of the die to the ambient temperature.

The junction temperature, T_J , is given by:

$$T_J = T_A + T_R$$

Where T_A is the ambient temperature.

T_J should be below the maximum junction temperature of 125°C.

PC Board Layout Checklist

When laying out the printed circuit board, the following guidelines should be used to ensure proper operation of the EUP3010/A.

1. The input capacitor C_{IN} should connect to V_{IN} as closely as possible. This capacitor provides the AC current to the internal power MOSFETs.
2. The power traces, consisting of the GND trace, the SW trace and the V_{IN} trace should be kept short, direct and wide.
3. The FB pin should connect directly to the feedback resistors. The resistive divider R1/R2 must be connected between the C_{OUT} and ground.
4. Keep the switching node, SW, away from the sensitive FB node.

Packaging Information

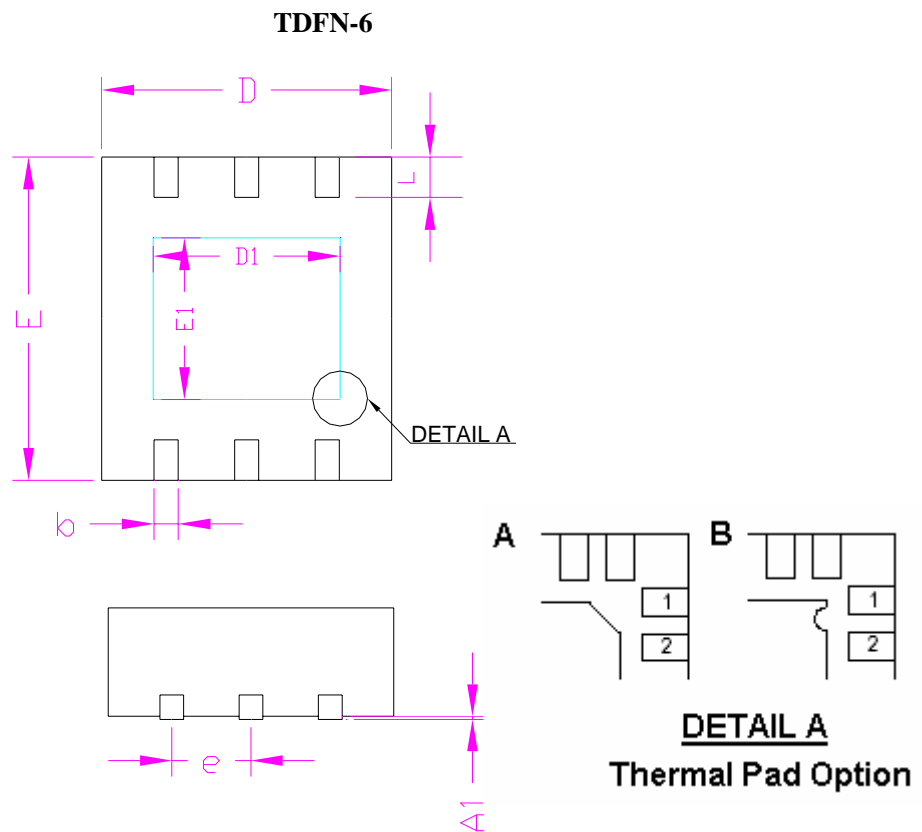

SYMBOLS	MILLIMETERS		INCHES	
	MIN.	MAX.	MIN.	MAX.
A	0.70	0.80	0.028	0.031
A1	0.00	0.05	0.000	0.002
b	0.20	0.40	0.008	0.016
D	1.90	2.10	0.075	0.083
D1	1.40		0.055	
E	1.90	2.10	0.075	0.083
E1	0.80		0.031	
e	0.65		0.026	
L	0.25	0.45	0.010	0.018

TQFN-16

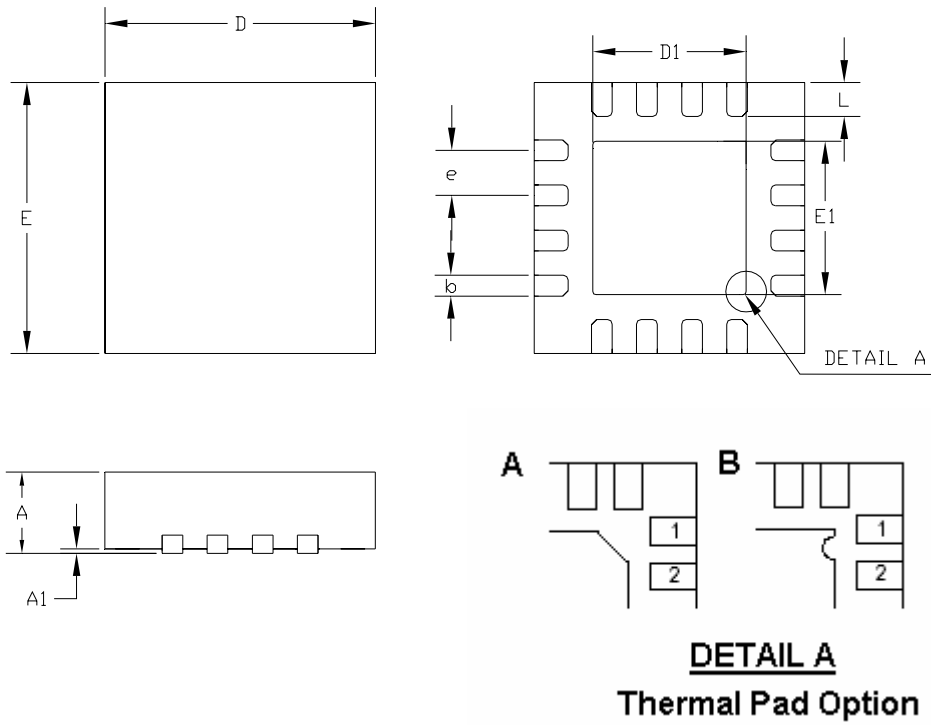

SYMBOLS	MILLIMETERS		INCHES	
	MIN.	MAX.	MIN.	MAX.
A	0.70	0.80	0.028	0.031
A1	0.00	0.05	0.000	0.002
b	0.18	0.30	0.007	0.012
E	2.90	3.10	0.114	0.122
D	2.90	3.10	0.114	0.122
D1	1.70		0.067	
E1	1.70		0.067	
e	0.50		0.020	
L	0.30	0.50	0.012	0.020