



TAI-SAW TECHNOLOGY CO., LTD.

No. 3, Industrial 2nd Rd., Ping-Chen Industrial District,
Taoyuan, 324, Taiwan, R.O.C.

TEL: 886-3-4690038 FAX: 886-3-4697532

E-mail: tstsales@mail.taisaw.com Web: www.taisaw.com

Product Specifications Approval Sheet

Product Description: SAW Resonator 834.64 MHz SMD 3.0X3.0 mm

TST Part No.: TC0537A

Customer Part No.: _____

Customer signature required
Company: _____
Division: _____
Approved by : _____
Date: _____

Checked by: Paul Ni *Paul Ni*

Approved by: Francis Chen *Francis Chen*

Date: 2009/11/05

1. Customer signed back is required before TST can proceed with sample build and receive orders.
2. Orders received without customer signed back will be regarded as agreement on the specifications.
3. Any specifications changes must be approved upon by both parties and a new revision of specifications shall be released to reflect the changes.



TAI-SAW TECHNOLOGY CO., LTD.

No. 3, Industrial 2nd Rd., Ping-Chen Industrial District,
Taoyuan, 324, Taiwan, R.O.C.

TEL: 886-3-4690038 FAX: 886-3-4697532

E-mail: tstsales@mail.taisaw.com Web: www.taisaw.com

SAW Resonator 834.64 MHz

MODEL NO.: TC0537A

REV. NO.: 2.0

A. FEATURES:

- 1-Port Resonator.

B. MAXIMUM RATING:

1. Input Power Level: 10 dBm
2. DC voltage: 3 V
3. Operating Temperature: -40°C to +85°C
4. Storage Temperature: -40°C to +85°C

RoHS Compliant
Lead free
Lead-free soldering

C. ELECTRICAL CHARACTERISTICS:

Characteristic	Units	Minimum	Typical	Maximum
Center frequency Fr	MHz	834.590	834.640	834.690
Insertion Loss IL	dB	-	1.37	2.0
Equivalent Elements				
Motional capacitance C1	fF	-	1.40	-
Motional inductance L1	μH	-	26.0	-
Motional resistance R1	Ohm	-	13.8	-
Parallel capacitance Co	pF	-	2.80	-
Temp.coeff.	ppm/c*2	-	0.032	-
Turnover To	deg.C	-	25	-
Package size		SMD 3.0X3.0X1.4mm		

D. EQUIVIRENT CIRCUIT:

One-Port Resonator:

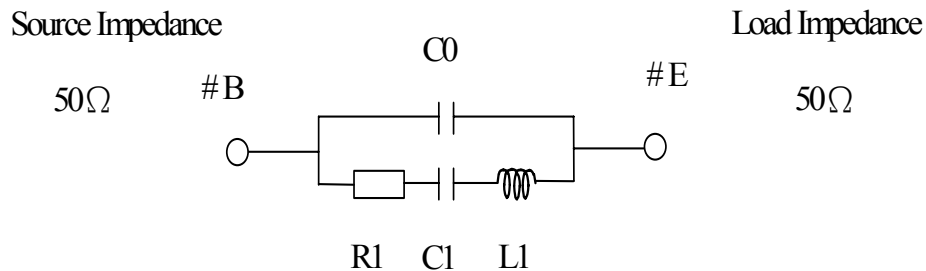

E. OUTLINE DRAWING:

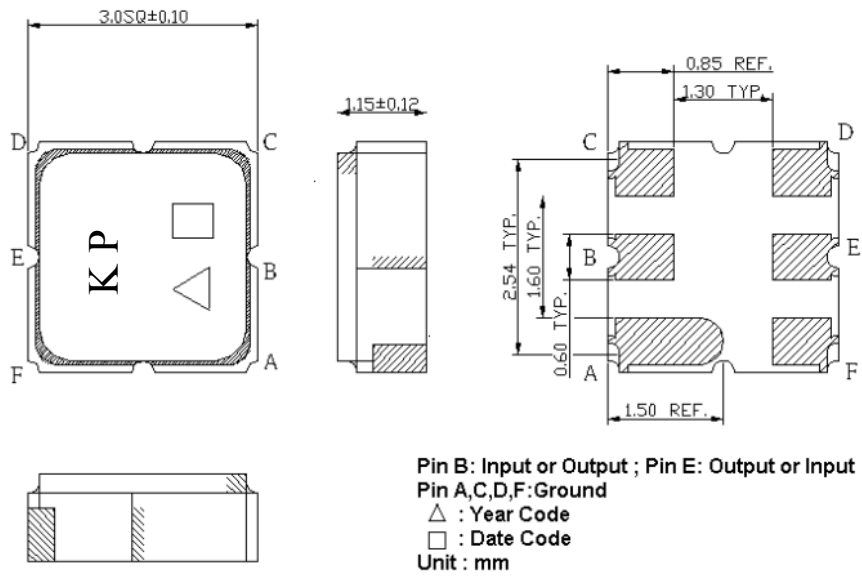

Date code: Provided by planer each year
 Year code: 9 for 2009, 0 for 2010, ..., 9 for 2019

F. FREQUENCY CHARACTERISTICS

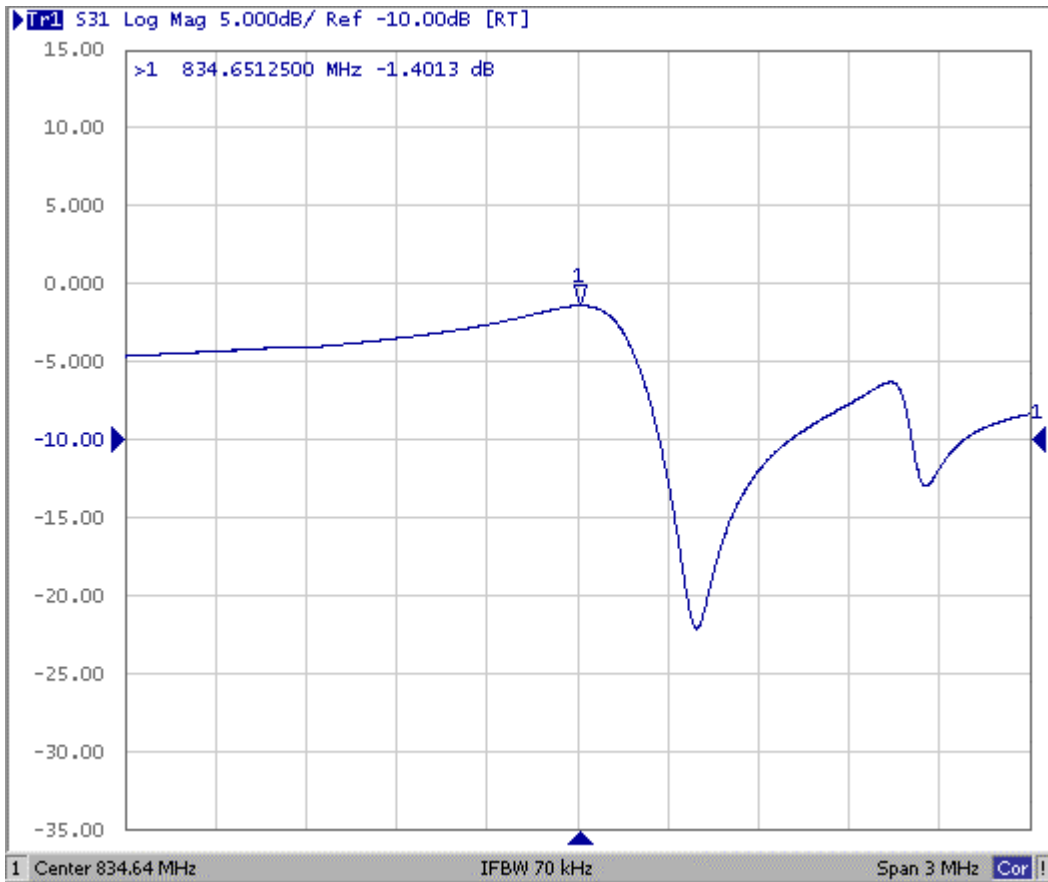

G. TEST CIRCUIT:

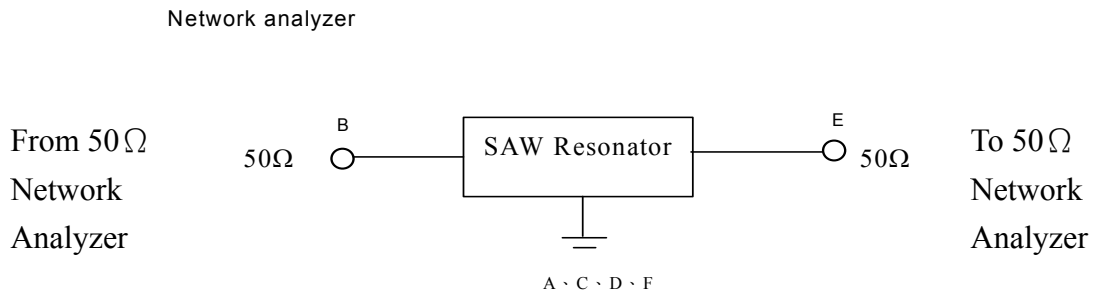

H. LAND PATTERN:

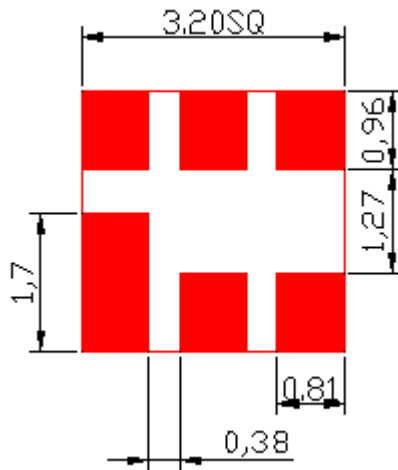

I. PACKING:

1. REEL DIMENSION

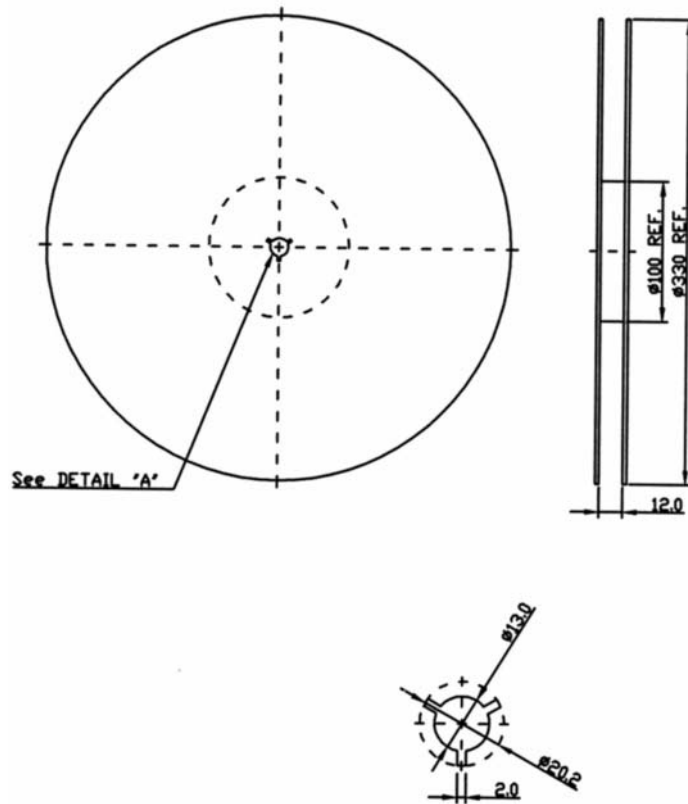

2. TAPE DIMENSION

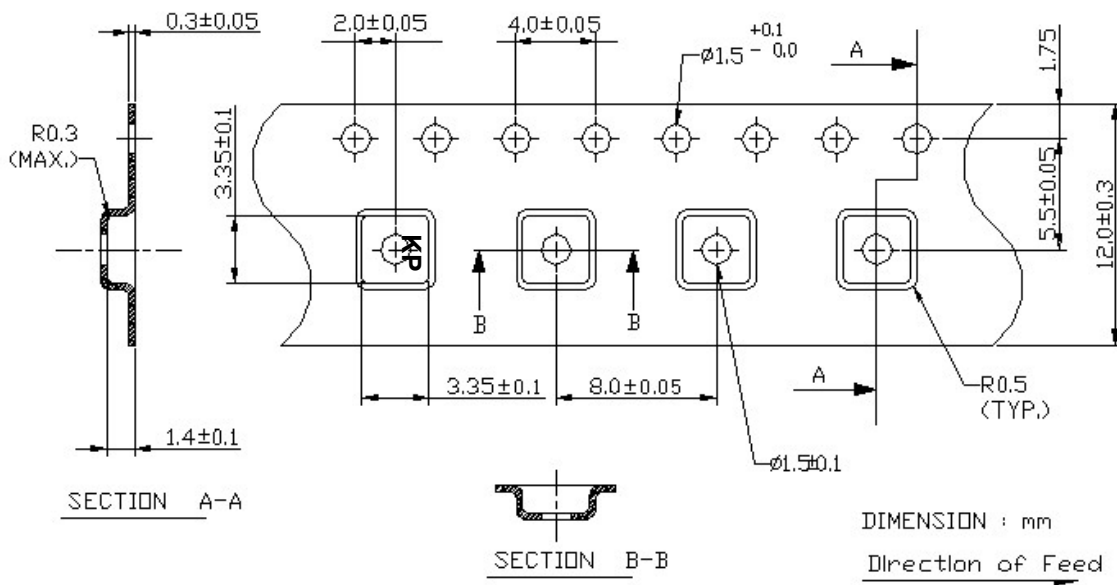

J. RECOMMENDED REFLOW PROFILE:

