

PCF8533

Universal LCD driver for low multiplex rates

Rev. 04 — 5 March 2010

Product data sheet

1. General description

The PCF8533 is a peripheral device which interfaces to almost any LCD¹ with low multiplex rates. It generates the drive signals for any static or multiplexed LCD containing up to four backplanes and up to 80 segments and can easily be cascaded for larger LCD applications. The PCF8533 is compatible with most microprocessors or microcontrollers and communicates via a two-line bidirectional I²C-bus. Communication overheads are minimized by a display RAM with auto-incremental addressing, by hardware subaddressing and by display memory switching (static and duplex drive modes).

2. Features and benefits

- Single-chip LCD controller and driver
- Selectable backplane drive configuration: static, 2, 3, or 4 backplane multiplexing
- Selectable display bias configuration: static, 1/2, or 1/3
- Internal LCD bias generation with voltage follower buffers
- 80 segment outputs allowing to drive:
 - ◆ 40 8-segment alphanumeric characters
 - ◆ 21 15-segment alphanumeric characters
 - ◆ Any graphics of up to 320 elements
- 80 × 4 bit RAM for display data storage
- Auto-incremental display data loading across device subaddress boundaries
- Display memory bank switching in static and duplex drive modes
- Versatile blinking modes
- Independent supplies possible for LCD and logic voltages
- Wide power supply range: from 1.8 V to 5.5 V
- Wide LCD supply range for low-threshold LCDs, for guest-host LCDs and high-threshold (automobile) twisted nematic LCDs from 2.5 V to 6.5 V
- Low power consumption
- 400 kHz I²C-bus interface
- TTL/CMOS compatible
- Compatible with 4-bit, 8-bit, or 16-bit microprocessors or microcontrollers
- May be cascaded for large LCD applications (up to 5120 elements possible)
- No external components required
- Compatible with Chip-On-Glass (COG) technology
- Manufactured using silicon gate CMOS process

1. The definition of the abbreviations and acronyms used in this data sheet can be found in [Section 18](#).



3. Ordering information

Table 1. Ordering information

Type number	Package		Delivery form ^[1]	Version
	Name	Description		
PCF8533U/2/F2	PCF8533-2	bare die; 99 bumps; 5.28 x 1.4 x 0.38 mm	chip with hard bumps in tray	-
PCF8533U/2DA/2	PCF8533-2	bare die; 99 bumps; 5.28 x 1.4 x 0.38 mm	chip with soft bumps in tray	-

[1] Bump hardness see [Table 20](#).

4. Marking

Table 2. Marking codes

Type number	Marking code
PCF8533U/2/F2	PC8533-2
PCF8533U/2DA/2	PC8533-2

5. Block diagram

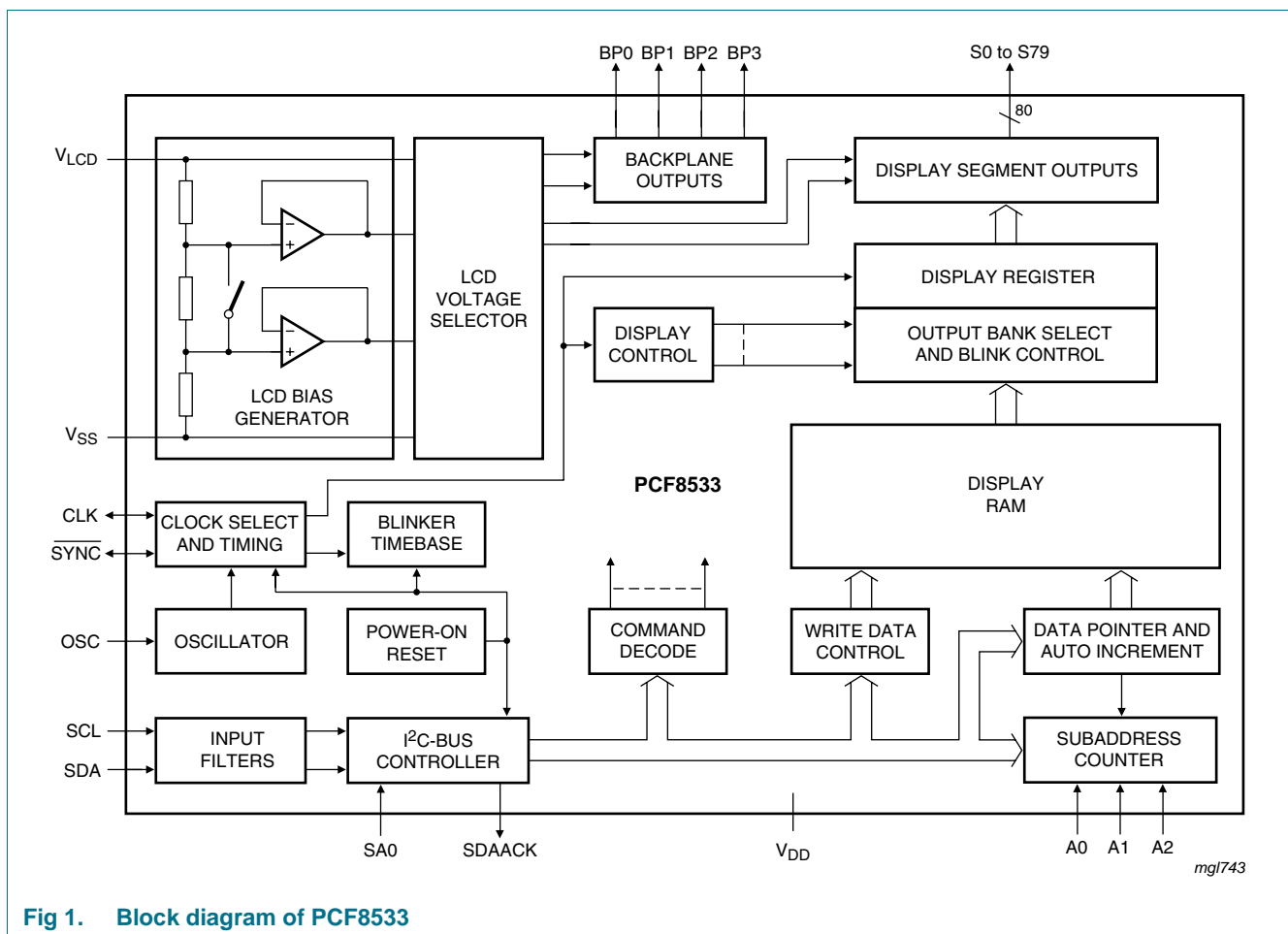

Fig 1. Block diagram of PCF8533

6. Pinning information

6.1 Pinning

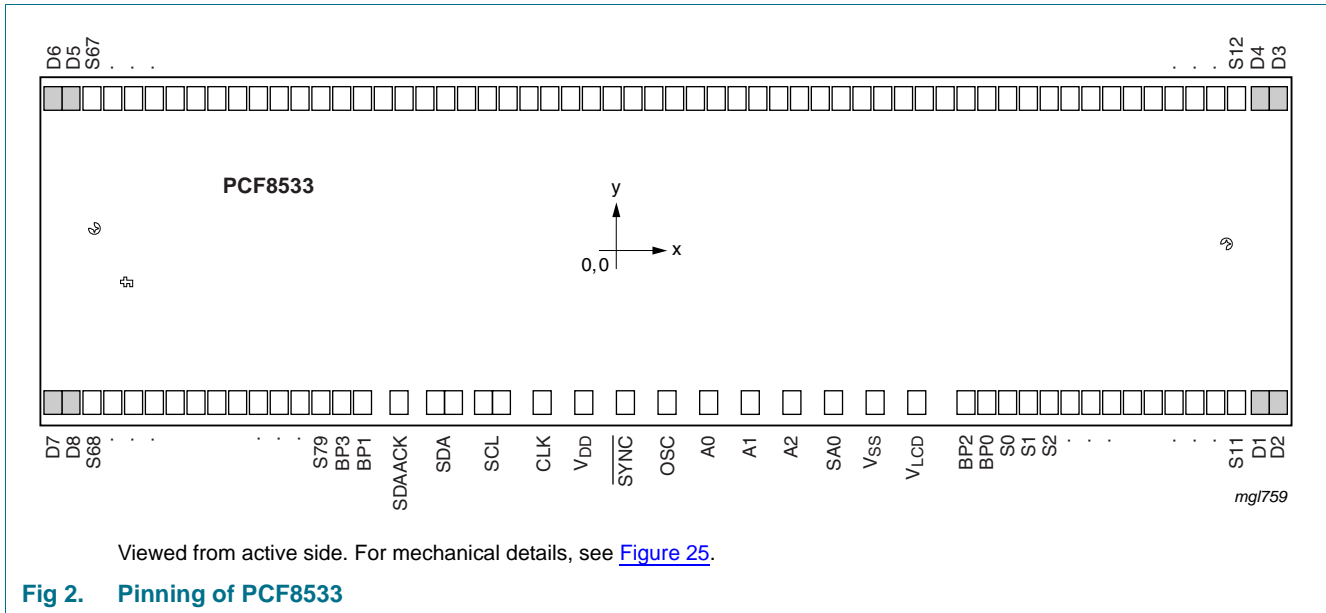

Fig 2. Pinning of PCF8533

6.2 Pin description

Table 3. Pin description overview

Symbol	Pin	Type	Description
SDAACK	1	output	I ² C-bus acknowledge
SDA	2 and 3	input/output	I ² C-bus serial data
SCL	4 and 5	input	I ² C-bus serial clock
CLK	6	input/output	clock input/output
V _{DD}	7	supply	supply voltage
SYNC	8	input/output	cascade synchronization
OSC	9	input	oscillator select
A0, A1 and A2	10 to 12	input	subaddress
SA0	13	input	I ² C-bus slave address
V _{SS}	14	supply	ground supply voltage
V _{LCD}	15	supply	LCD supply voltage
BP0, BP1, BP2 and BP3	17, 99, 16 and 98	output	LCD backplane output
S0 to S79	18 to 97	output	LCD segment output
D1, D2, D3, D4, D5, D6, D7, D8,		-	dummy pins

7. Functional description

The PCF8533 is a versatile peripheral device designed to interface any microprocessor or microcontroller to a wide variety of LCDs. It can directly drive any static or multiplexed LCD containing up to four backplanes and up to 80 segments.

The display configurations possible with the PCF8533 depend on the number of active backplane outputs required. A selection of display configurations is given in [Table 4](#); all of these configurations can be implemented in the typical system shown in [Figure 3](#).

Table 4. Selection of display configurations

Number of		8-segment alphanumeric		15-segment alphanumeric		Dot matrix
Backplanes	Elements	Digits	Indicator symbols	Characters	Indicator symbols	
4	320	40	40	20	40	320 (4 × 80)
3	240	30	30	16	16	240 (3 × 80)
2	160	20	20	10	20	160 (2 × 80)
1	80	10	10	5	10	80 (1 × 80)

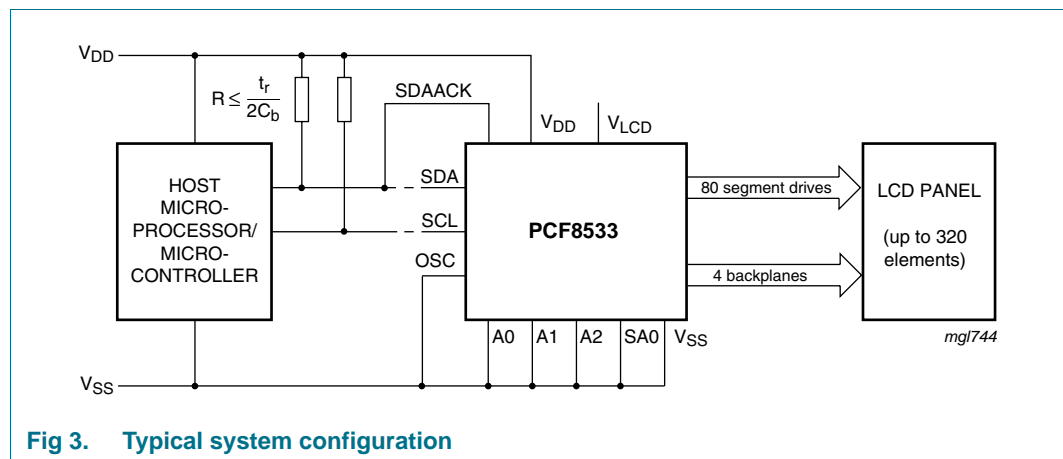

Fig 3. Typical system configuration

The host microprocessor or microcontroller maintains the 2-line I²C-bus communication channel with the PCF8533.

Biasing voltages for the multiplexed LCD waveforms are generated internally, removing the need for an external bias generator. The internal oscillator is selected by connecting pin OSC to V_{SS}. The only other connections required to complete the system are the power supplies (pins V_{DD}, V_{SS} and V_{LCD}) and the LCD panel selected for the application.

7.1 Power-on reset

At power-on the PCF8533 resets to the following starting conditions:

1. All backplane outputs are set to V_{LCD}.
2. All segment outputs are set to V_{LCD}.
3. The selected drive mode is: 1:4 multiplex with 1/3 bias.
4. Blinking is switched off.
5. Input and output bank selectors are reset.

6. The I²C-bus interface is initialized.
7. The data pointer and the subaddress counter are cleared (set to logic 0).
8. The display is disabled.

Remark: Do not transfer data on the I²C-bus for at least 1 ms after a power-on to allow the reset action to complete.

7.2 LCD bias generator

Fractional LCD biasing voltages are obtained from an internal voltage divider of three series resistors connected between pins V_{LCD} and V_{SS}. The center resistor is bypassed by switch if the 1/2 bias voltage level for the 1:2 multiplex drive mode configuration is selected.

7.3 LCD voltage selector

The LCD voltage selector coordinates the multiplexing of the LCD in accordance with the selected LCD drive configuration. The operation of the voltage selector is controlled by the mode-set command (see [Table 10](#)) from the command decoder. The biasing configurations that apply to the preferred modes of operation, together with the biasing characteristics as functions of V_{LCD} and the resulting discrimination ratios (D) are given in [Table 5](#).

Table 5. Biasing characteristics

LCD drive mode	Number of:		LCD bias configuration	$\frac{V_{off(RMS)}}{V_{LCD}}$	$\frac{V_{on(RMS)}}{V_{LCD}}$	$D = \frac{V_{on(RMS)}}{V_{off(RMS)}}$
	Backplanes	Levels				
static	1	2	static	0	1	∞
1:2 multiplex	2	3	1/2	0.354	0.791	2.236
1:2 multiplex	2	4	1/3	0.333	0.745	2.236
1:3 multiplex	3	4	1/3	0.333	0.638	1.915
1:4 multiplex	4	4	1/3	0.333	0.577	1.732

A practical value for V_{LCD} is determined by equating V_{off(RMS)} with a defined LCD threshold voltage (V_{th}), typically when the LCD exhibits approximately 10 % contrast. In the static drive mode a suitable choice is V_{LCD} > 3V_{th}.

Multiplex drive modes of 1:3 and 1:4 with 1/2 bias are possible but the discrimination and hence the contrast ratios are smaller.

Bias is calculated by $\frac{1}{1+a}$, where the values for a are

a = 1 for 1/2 bias

a = 2 for 1/3 bias

The RMS on-state voltage (V_{on(RMS)}) for the LCD is calculated with [Equation 1](#):

$$V_{on(RMS)} = V_{LCD} \sqrt{\frac{a^2 + 2a + n}{n \times (1 + a)^2}} \tag{1}$$

where the values for n are

- n = 1 for static drive mode
- n = 2 for 1:2 multiplex drive mode
- n = 3 for 1:3 multiplex drive mode
- n = 4 for 1:4 multiplex drive mode

The RMS off-state voltage ($V_{off(RMS)}$) for the LCD is calculated with [Equation 2](#):

$$V_{off(RMS)} = V_{LCD} \sqrt{\frac{a^2 - 2a + n}{n \times (1 + a)^2}} \quad (2)$$

Discrimination is the ratio of $V_{on(RMS)}$ to $V_{off(RMS)}$ and is determined from [Equation 3](#):

$$D = \frac{V_{on(RMS)}}{V_{off(RMS)}} = \sqrt{\frac{(a + 1)^2 + (n - 1)}{(a - 1)^2 + (n - 1)}} \quad (3)$$

Using [Equation 3](#), the discrimination for an LCD drive mode of 1:3 multiplex with $\frac{1}{2}$ bias is $\sqrt{3} = 1.732$ and the discrimination for an LCD drive mode of 1:4 multiplex with $\frac{1}{2}$ bias is $\frac{\sqrt{21}}{3} = 1.528$.

The advantage of these LCD drive modes is a reduction of the LCD full scale voltage V_{LCD} as follows:

- 1:3 multiplex ($\frac{1}{2}$ bias): $V_{LCD} = \sqrt{6} \times V_{off(RMS)} = 2.449 V_{off(RMS)}$
- 1:4 multiplex ($\frac{1}{2}$ bias): $V_{LCD} = \left[\frac{4 \times \sqrt{3}}{3} \right] = 2.309 V_{off(RMS)}$

These compare with $V_{LCD} = 3 V_{off(RMS)}$ when $\frac{1}{3}$ bias is used.

It should be noted that V_{LCD} is sometimes referred as the LCD operating voltage.

7.4 LCD drive mode waveforms

7.4.1 Static drive mode

The static LCD drive mode is used when a single backplane is provided in the LCD. The backplane (BP0) and segment drive (Sn) waveforms for this mode are shown in [Figure 4](#).

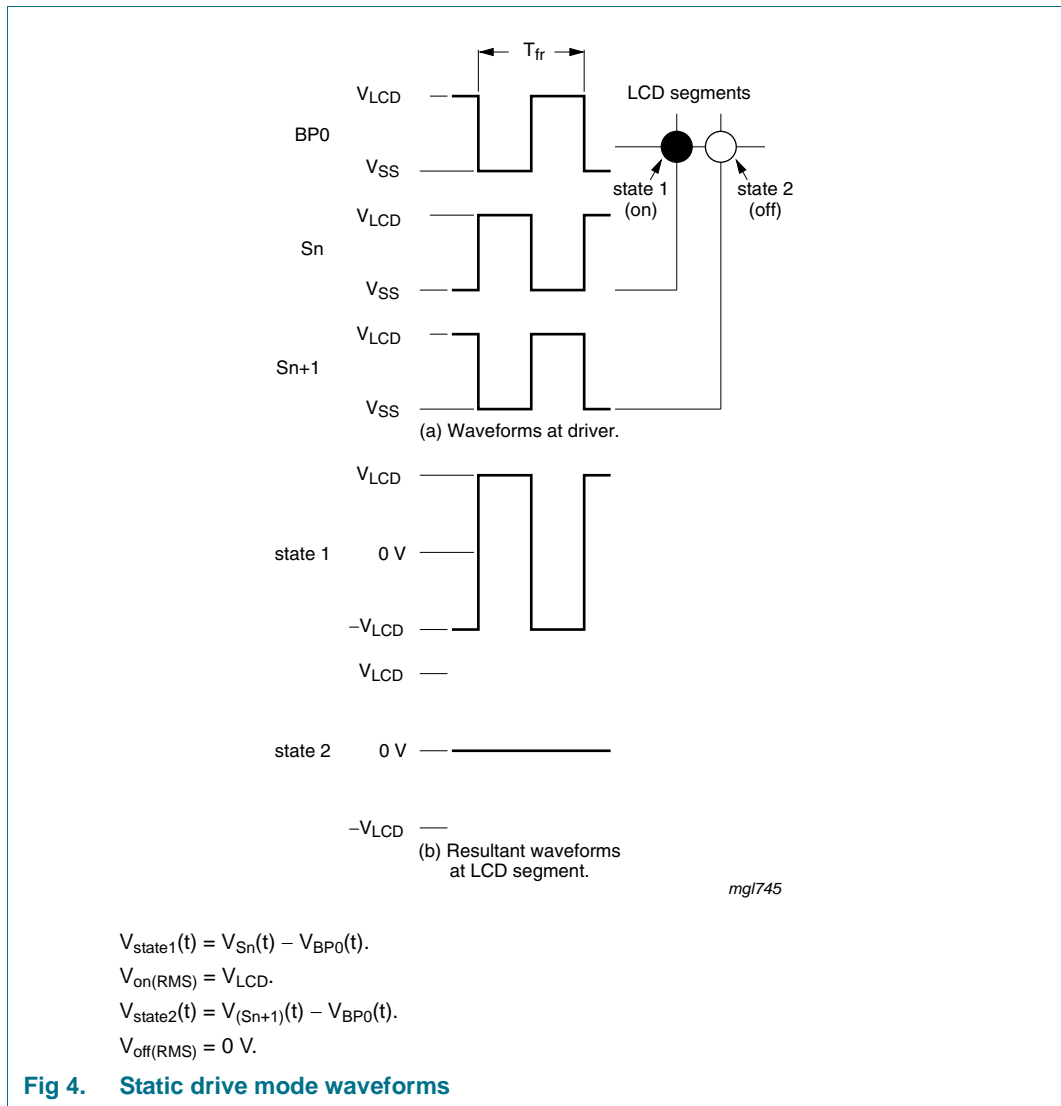

Fig 4. Static drive mode waveforms

7.4.2 1:2 multiplex drive mode

The 1:2 multiplex drive mode is used when two backplanes are provided in the LCD. This mode allows fractional LCD bias voltages of $\frac{1}{2}$ bias or $\frac{1}{3}$ bias as shown in [Figure 5](#) and [Figure 6](#).

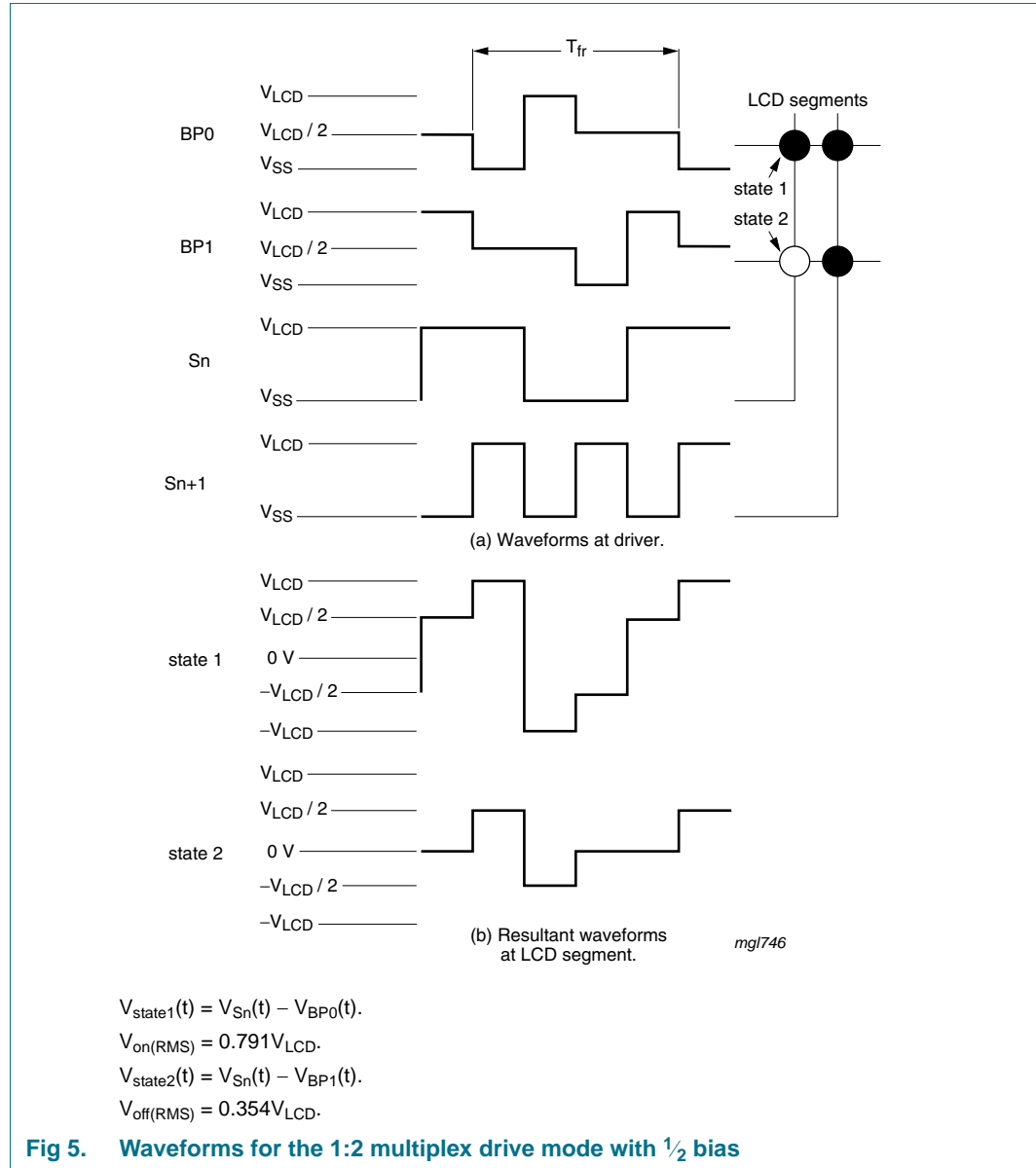

Fig 5. Waveforms for the 1:2 multiplex drive mode with $\frac{1}{2}$ bias

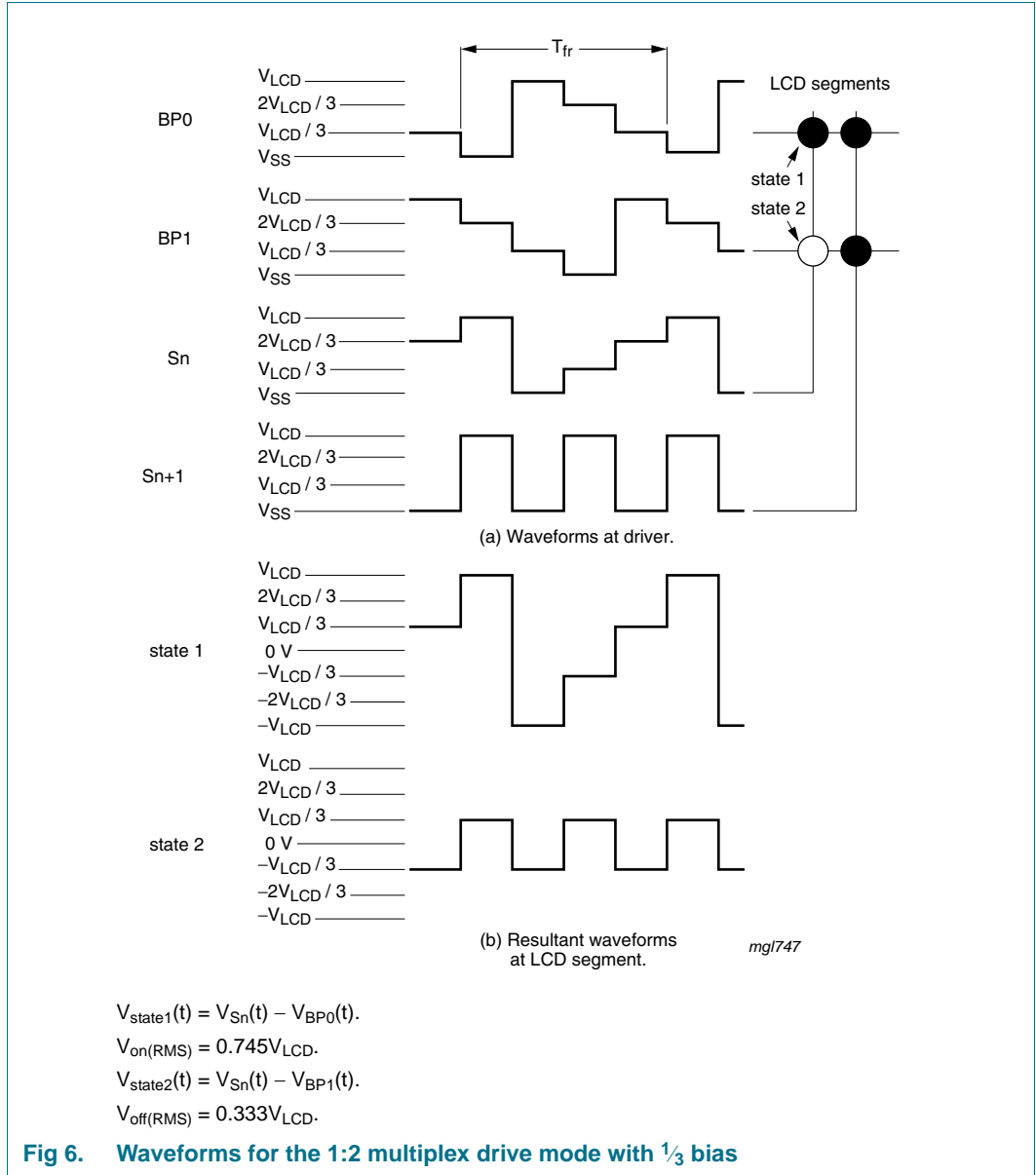
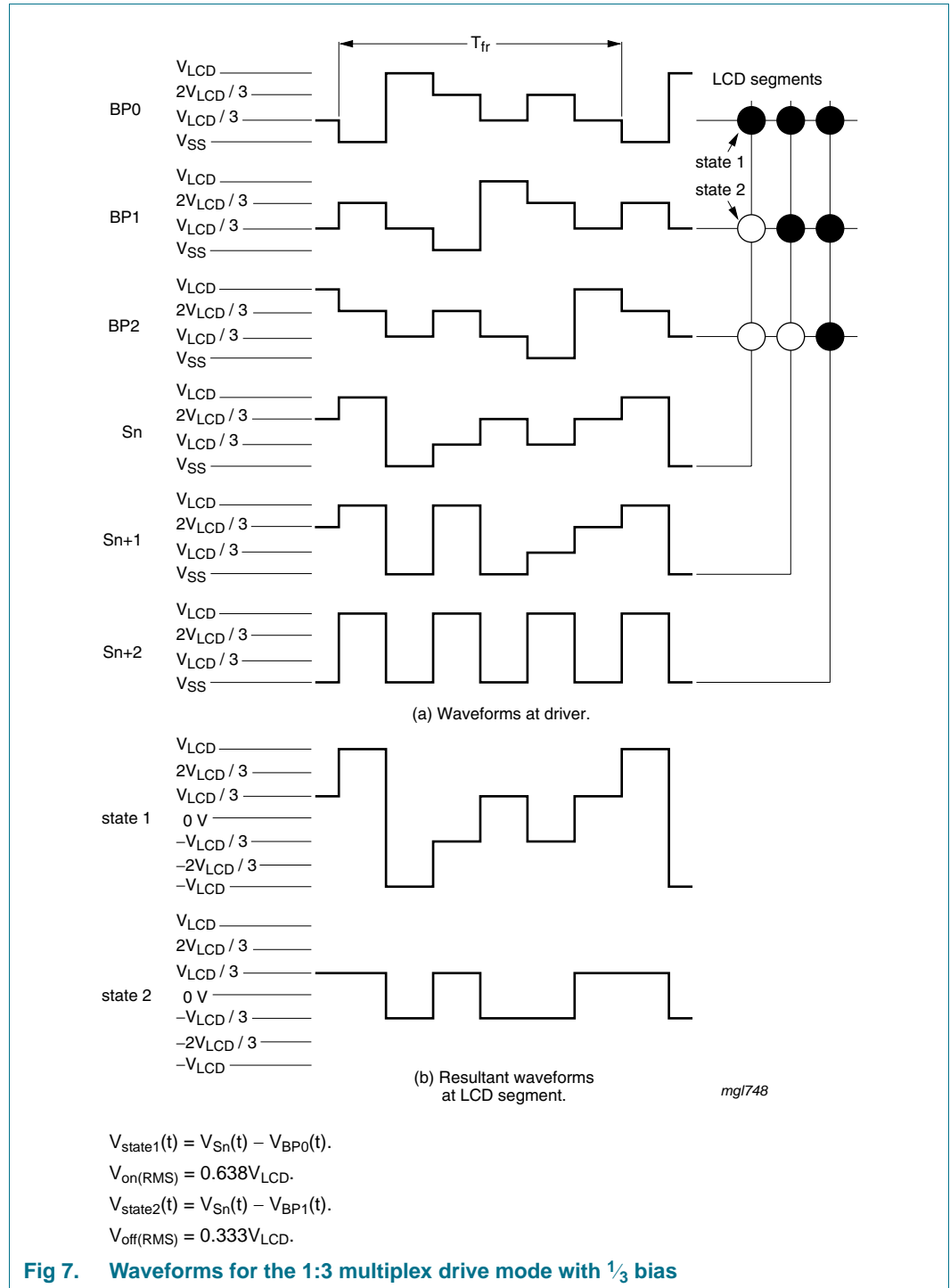

Fig 6. Waveforms for the 1:2 multiplex drive mode with 1/3 bias

7.4.3 1:3 multiplex drive mode

The 1:3 multiplex drive mode is used when three backplanes are provided in the LCD as shown in Figure 7.



7.4.4 1:4 multiplex drive mode

The 1:4 multiplex drive mode is used when four backplanes are provided in the LCD as shown in Figure 8.

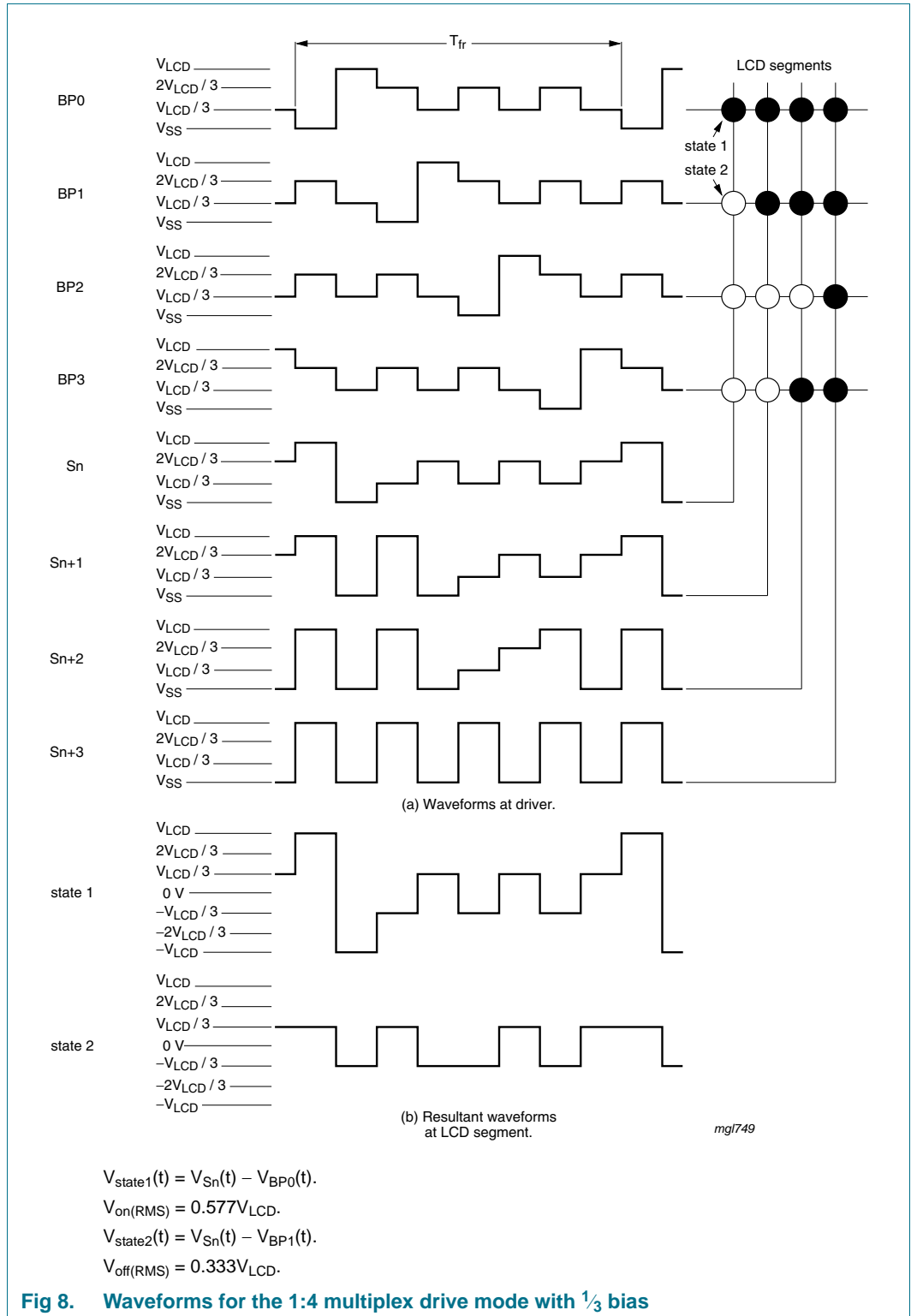

7.5 Oscillator

The internal logic and the LCD drive signals of the PCF8533 are timed by a frequency f_{clk} , which either is derived from the built-in oscillator frequency f_{osc} or equals an external clock frequency $f_{clk(ext)}$.

$$f_{clk} = \frac{f_{osc}}{64}$$

The clock frequency f_{clk} determines the LCD frame frequency f_{fr} (see [Table 6](#)) and is calculated as follows:

$$f_{fr} = \frac{f_{clk}}{24}$$

Table 6. LCD frame frequency

Nominal clock frequency (Hz)	LCD frame frequency (Hz)
1 536	64

7.5.1 Internal clock

The internal oscillator is enabled by connecting pin OSC to V_{SS} . In this case the output from pin CLK provides the clock signal for cascaded PCF8533s in the system.

7.5.2 External clock

Pin CLK is enabled as an external clock input by connecting pin OSC to V_{DD} .

A clock signal must always be supplied to the device; removing the clock may freeze the LCD in a DC state, which is not suitable for the liquid crystal.

7.6 Timing

The PCF8533 timing controls the internal data flow of the device. This includes the transfer of display data from the display RAM to the display segment outputs. In cascaded applications, the synchronization signal (\overline{SYNC}) maintains the correct timing relationship between the PCF8533s in the system. The timing also generates the LCD frame signal (f_{fr}) whose frequency is derived as an integer division of the clock frequency f_{clk} (see [Table 6](#)), applied to pin CLK from either the internal or an external clock.

7.7 Display register

The display register holds the display data while the corresponding multiplex signals are generated. There is a one-to-one relationship between the data in the display register, the LCD segment outputs and each column of the display RAM.

7.8 Segment outputs

The LCD drive section includes 80 segment outputs (S0 to S79) which must be connected directly to the LCD. The segment output signals are generated in accordance with the multiplexed backplane signals and with data residing in the display register. If less than 80 segment outputs are required, the unused segment outputs must be left open-circuit.

7.9 Backplane outputs

The LCD drive section includes four backplane outputs: BP0 to BP3. The backplane output signals are generated based on the selected LCD drive mode.

- In 1:4 multiplex drive mode: BP0 to BP3 must be connected directly to the LCD.

If less than four backplane outputs are required the unused outputs can be left open-circuit.

- In 1:3 multiplex drive mode: BP3 carries the same signal as BP1, therefore these two adjacent outputs can be tied together to give enhanced drive capabilities.
- In 1:2 multiplex drive mode: BP0 and BP2, BP1 and BP3 respectively carry the same signals and can also be paired to increase the drive capabilities.
- In static drive mode: The same signal is carried by all four backplane outputs; and they can be connected in parallel for very high drive requirements.

7.10 Display RAM

The display RAM is a static 80 × 4 bit RAM which stores LCD data. A logic 1 in the RAM bit map indicates the on-state of the corresponding LCD element; similarly, a logic 0 indicates the off state. There is a one-to-one correspondence between the RAM addresses and the segment outputs and between the individual bits of a RAM word and the backplane outputs. The display RAM bit map [Figure 9](#) shows rows 0 to 3 which correspond with the backplane outputs BP0 to BP3, and columns 0 to 79 which correspond with the segment outputs S0 to S79. In multiplexed LCD applications the segment data of the first, second, third and fourth row of the display RAM are time-multiplexed with BP0, BP1, BP2, and BP3 respectively.

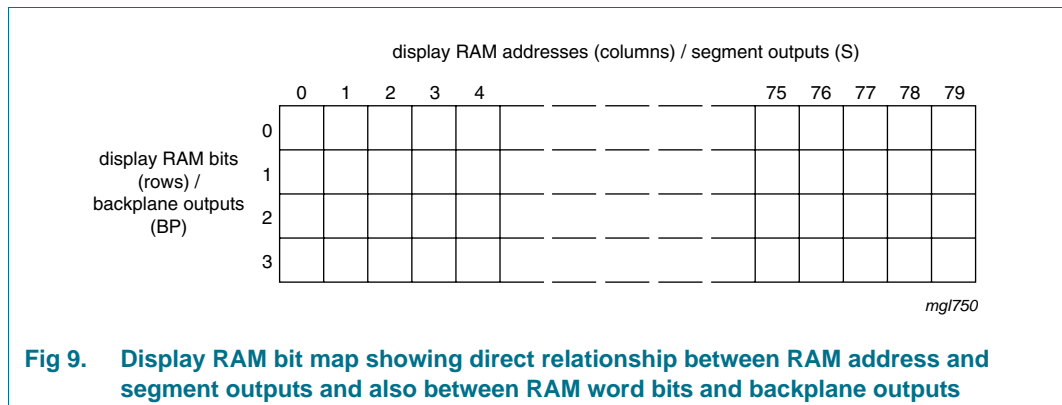

When display data is transmitted to the PCF8533, the received display bytes are stored in the display RAM in accordance with the selected LCD drive mode. The data is stored as it arrives and does not wait for the acknowledge cycle as with the commands. Depending on the current multiplex drive mode, data is stored singularly, in pairs, triples or quadruples. To illustrate the filling order, an example of a 8-segment numeric display showing all drive modes is given in [Figure 10](#); the RAM filling organization depicted applies equally to other LCD types.

drive mode	LCD segments	LCD backplanes	display RAM filling order	transmitted display byte																																																									
static			<p>columns display RAM address/segment outputs (s) byte1</p> <table border="1"> <tr> <td></td> <td>n</td> <td>n + 1</td> <td>n + 2</td> <td>n + 3</td> <td>n + 4</td> <td>n + 5</td> <td>n + 6</td> <td>n + 7</td> </tr> <tr> <td>rows display RAM</td> <td>0</td> <td>c</td> <td>b</td> <td>a</td> <td>f</td> <td>g</td> <td>e</td> <td>d</td> <td>DP</td> </tr> <tr> <td>rows/backplane</td> <td>1</td> <td>x</td> <td>x</td> <td>x</td> <td>x</td> <td>x</td> <td>x</td> <td>x</td> <td>x</td> </tr> <tr> <td>outputs (BP)</td> <td>2</td> <td>x</td> <td>x</td> <td>x</td> <td>x</td> <td>x</td> <td>x</td> <td>x</td> <td>x</td> </tr> <tr> <td></td> <td>3</td> <td>x</td> <td>x</td> <td>x</td> <td>x</td> <td>x</td> <td>x</td> <td>x</td> <td>x</td> </tr> </table>		n	n + 1	n + 2	n + 3	n + 4	n + 5	n + 6	n + 7	rows display RAM	0	c	b	a	f	g	e	d	DP	rows/backplane	1	x	x	x	x	x	x	x	x	outputs (BP)	2	x	x	x	x	x	x	x	x		3	x	x	x	x	x	x	x	x	<p>MSB</p> <p>LSB</p> <table border="1"> <tr> <td>c</td> <td>b</td> <td>a</td> <td>f</td> <td>g</td> <td>e</td> <td>d</td> <td>DP</td> </tr> </table>	c	b	a	f	g	e	d	DP
	n	n + 1	n + 2	n + 3	n + 4	n + 5	n + 6	n + 7																																																					
rows display RAM	0	c	b	a	f	g	e	d	DP																																																				
rows/backplane	1	x	x	x	x	x	x	x	x																																																				
outputs (BP)	2	x	x	x	x	x	x	x	x																																																				
	3	x	x	x	x	x	x	x	x																																																				
c	b	a	f	g	e	d	DP																																																						
1:2 multiplex			<p>columns display RAM address/segment outputs (s) byte1</p> <table border="1"> <tr> <td></td> <td>n</td> <td>n + 1</td> <td>n + 2</td> <td>n + 3</td> </tr> <tr> <td>rows display RAM</td> <td>0</td> <td>a</td> <td>f</td> <td>e</td> <td>d</td> </tr> <tr> <td>rows/backplane</td> <td>1</td> <td>b</td> <td>g</td> <td>c</td> <td>DP</td> </tr> <tr> <td>outputs (BP)</td> <td>2</td> <td>x</td> <td>x</td> <td>x</td> <td>x</td> </tr> <tr> <td></td> <td>3</td> <td>x</td> <td>x</td> <td>x</td> <td>x</td> </tr> </table>		n	n + 1	n + 2	n + 3	rows display RAM	0	a	f	e	d	rows/backplane	1	b	g	c	DP	outputs (BP)	2	x	x	x	x		3	x	x	x	x	<p>MSB</p> <p>LSB</p> <table border="1"> <tr> <td>a</td> <td>b</td> <td>f</td> <td>g</td> <td>e</td> <td>c</td> <td>d</td> <td>DP</td> </tr> </table>	a	b	f	g	e	c	d	DP																				
	n	n + 1	n + 2	n + 3																																																									
rows display RAM	0	a	f	e	d																																																								
rows/backplane	1	b	g	c	DP																																																								
outputs (BP)	2	x	x	x	x																																																								
	3	x	x	x	x																																																								
a	b	f	g	e	c	d	DP																																																						
1:3 multiplex			<p>columns display RAM address/segment outputs (s) byte1</p> <table border="1"> <tr> <td></td> <td>n</td> <td>n + 1</td> <td>n + 2</td> </tr> <tr> <td>rows display RAM</td> <td>0</td> <td>b</td> <td>a</td> <td>f</td> </tr> <tr> <td>rows/backplane</td> <td>1</td> <td>DP</td> <td>d</td> <td>e</td> </tr> <tr> <td>outputs (BP)</td> <td>2</td> <td>c</td> <td>g</td> <td>x</td> </tr> <tr> <td></td> <td>3</td> <td>x</td> <td>x</td> <td>x</td> </tr> </table>		n	n + 1	n + 2	rows display RAM	0	b	a	f	rows/backplane	1	DP	d	e	outputs (BP)	2	c	g	x		3	x	x	x	<p>MSB</p> <p>LSB</p> <table border="1"> <tr> <td>b</td> <td>DP</td> <td>c</td> <td>a</td> <td>d</td> <td>g</td> <td>f</td> <td>e</td> </tr> </table>	b	DP	c	a	d	g	f	e																									
	n	n + 1	n + 2																																																										
rows display RAM	0	b	a	f																																																									
rows/backplane	1	DP	d	e																																																									
outputs (BP)	2	c	g	x																																																									
	3	x	x	x																																																									
b	DP	c	a	d	g	f	e																																																						
1:4 multiplex			<p>columns display RAM address/segment outputs (s) byte1</p> <table border="1"> <tr> <td></td> <td>n</td> <td>n + 1</td> </tr> <tr> <td>rows display RAM</td> <td>0</td> <td>a</td> <td>f</td> </tr> <tr> <td>rows/backplane</td> <td>1</td> <td>c</td> <td>e</td> </tr> <tr> <td>outputs (BP)</td> <td>2</td> <td>b</td> <td>g</td> </tr> <tr> <td></td> <td>3</td> <td>DP</td> <td>d</td> </tr> </table>		n	n + 1	rows display RAM	0	a	f	rows/backplane	1	c	e	outputs (BP)	2	b	g		3	DP	d	<p>MSB</p> <p>LSB</p> <table border="1"> <tr> <td>a</td> <td>c</td> <td>b</td> <td>DP</td> <td>f</td> <td>e</td> <td>g</td> <td>d</td> </tr> </table>	a	c	b	DP	f	e	g	d																														
	n	n + 1																																																											
rows display RAM	0	a	f																																																										
rows/backplane	1	c	e																																																										
outputs (BP)	2	b	g																																																										
	3	DP	d																																																										
a	c	b	DP	f	e	g	d																																																						

001aa|646

x = data bit unchanged.

Fig 10. Relationship between LCD layout, drive mode, display RAM storage order and display data transmitted over the I²C-bus

The following applies to [Figure 10](#):

- In static drive mode the eight transmitted data bits are placed into row 0 of eight successive 4-bit RAM words.
- In 1:2 multiplex mode the eight transmitted data bits are placed in pairs into row 0 and 1 of four successive 4-bit RAM words.
- In 1:3 multiplex mode the eight bits are placed in triples into row 0, 1, and 2 of three successive 4-bit RAM words, with bit 3 of the third address left unchanged. It is not recommended to use this bit in a display because of the difficult addressing. This last bit may, if necessary, be controlled by an additional transfer to this address, but care should be taken to avoid overwriting adjacent data because always full bytes are transmitted.
- In the 1:4 multiplex mode the eight transmitted data bits are placed in quadruples into row 0, 1, 2, and 3 of two successive 4-bit RAM words.

7.11 Data pointer

The addressing mechanism for the display RAM is realized using the data pointer. This allows the loading of an individual display data byte, or a series of display data bytes, into any location of the display RAM. The sequence commences with the initialization of the data pointer by the load-data-pointer command (see [Table 11](#)). Following this command, an arriving data byte is stored at the display RAM address indicated by the data pointer. The filling order is shown in [Figure 10](#). After each byte is stored, the content of the data pointer is automatically incremented by a value dependent on the selected LCD drive mode:

- In static drive mode by eight.
- In 1:2 multiplex drive mode by four.
- In 1:3 multiplex drive mode by three.
- In 1:4 multiplex drive mode by two.

If an I²C-bus data access terminates early, the state of the data pointer is unknown. Consequently, the data pointer must be rewritten prior to further RAM accesses.

7.12 Subaddress counter

The storage of display data is conditioned by the content of the subaddress counter. Storage is allowed only when the content of the subaddress counter match with the hardware subaddress applied to A0, A1, and A2. The subaddress counter value is defined by the device-select command (see [Table 12](#)). If the content of the subaddress counter and the hardware subaddress do not match, then data storage is inhibited but the data pointer is incremented as if data storage had taken place. The subaddress counter is also incremented when the data pointer overflows.

In cascaded applications each PCF8533 in the cascade must be addressed separately. Initially, the first PCF8533 is selected by sending the device-select command matching the first device's hardware subaddress. Then the data pointer is set to the preferred display RAM address by sending the load-data-pointer command.

Once the display RAM of the first PCF8533 has been written, the second PCF8533 is selected by sending the device-select command again. This time however the command matches the second device's hardware subaddress. Next the load-data-pointer command is sent to select the preferred display RAM address of the second PCF8533.

This last step is very important because during writing data to the first PCF8533, the data pointer of the second PCF8533 is incremented. In addition, the hardware subaddress should not be changed whilst the device is being accessed on the I²C-bus interface.

7.13 Output bank selector

The output bank selector (see [Table 13](#)) selects one of the four rows per display RAM address for transfer to the display register. The actual row selected depends on the particular LCD drive mode in operation and on the instant in the multiplex sequence.

- In 1:4 multiplex mode, all RAM addresses of row 0 are selected, these are followed by the contents of row 1, 2, and then 3
- In 1:3 multiplex mode, rows 0, 1, and 2 are selected sequentially
- In 1:2 multiplex mode, rows 0 and 1 are selected
- In static mode, row 0 is selected

The $\overline{\text{SYNC}}$ signal resets these sequences to the following starting points: bit 3 for 1:4 multiplex, bit 2 for 1:3 multiplex, bit 1 for 1:2 multiplex, and bit 0 for static mode.

The PCF8533 includes a RAM bank switching feature in the static and 1:2 multiplex drive modes. In the static drive mode, the bank-select command may request the contents of row 2 to be selected for display instead of the contents of row 0. In the 1:2 mode, the contents of rows 2 and 3 may be selected instead of rows 0 and 1. This gives the provision for preparing display information in an alternative bank and to be able to switch to it, once it is assembled.

7.14 Input bank selector

The input bank selector loads display data into the display RAM in accordance with the selected LCD drive configuration. Display data can be loaded in row 2 in static drive mode or in rows 2 and 3 in 1:2 multiplex drive mode by using the bank-select command. The input bank selector functions independently to the output bank selector.

7.15 Blinker

The PCF8533 has a very versatile display blinking capability. The whole display can blink at a frequency selected by the blink-select command. Each blink frequency is a fraction of the clock frequency. The ratio between the clock frequency and blink frequency depends on the blink mode selected, as shown in [Table 7](#).

The entire display can be blinked at a frequency other than the nominal blink frequency by sequentially resetting and setting the display enable bit E at the required rate using the mode-set command.

An additional feature allows an arbitrary selection of LCD segments to be blinked in the static and 1:2 drive modes. This is implemented without any communication overheads by the output bank selector which alternates the displayed data between the data in the display RAM bank and the data in an alternative RAM bank at the blink frequency. This mode can also be implemented by the blink-select command.

In the 1:3 and 1:4 drive modes, where no alternate RAM bank is available, groups of LCD elements can be blinked by selectively changing the display RAM data at fixed time intervals.

Table 7. Blink frequencies

Blink mode	Normal operating mode ratio	Nominal blink frequency of f_{clk} typical $f_{clk} = 1.536$ kHz	Unit
Off	-	blinking off	Hz
1	$\frac{f_{clk}}{768}$	2	Hz
2	$\frac{f_{clk}}{1536}$	1	Hz
3	$\frac{f_{clk}}{3072}$	0.5	Hz

8. I²C-bus interface

8.1 Characteristics of the I²C-bus

The I²C-bus is for bidirectional, two-line communication between different ICs or modules. The two lines are a Serial Data line (SDA) and a Serial Clock Line (SCL). Both lines must be connected to a positive supply via a pull-up resistor when connected to the output stages of a device. Data transfer may be initiated only when the bus is not busy.

By connecting pin SDAACK to pin SDA on the PCF8533, the SDA line becomes fully I²C-bus compatible. Having the acknowledge output separated from the serial data line is advantageous in Chip-On-Glass (COG) applications. In COG applications where the track resistance from the SDAACK pin to the system SDA line can be significant, a potential divider is generated by the bus pull-up resistor and the Indium Tin Oxide (ITO) track resistance. It is possible that during the acknowledge cycle the PCF8533 will not be able to create a valid logic 0 level. By separating the SDA input from the output the device could be used in a mode that ignores the acknowledge bit. In COG applications where the acknowledge cycle is required, it is necessary to minimize the track resistance from the SDAACK pin to the system SDA line to guarantee a valid LOW level.

The following definition assumes SDA and SDAACK are connected and refers to the pair as SDA.

8.1.1 Bit transfer

One data bit is transferred during each clock pulse. The data on the SDA line must remain stable during the HIGH period of the clock pulse as changes in the data line at this time will be interpreted as a control signal; see [Figure 11](#).

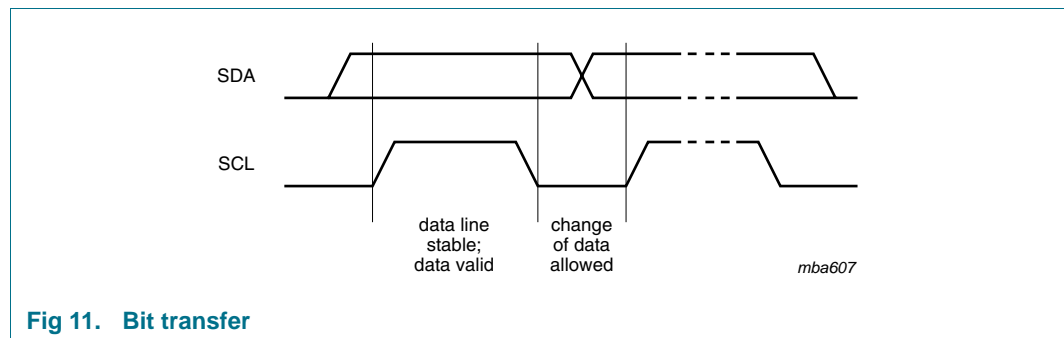

Fig 11. Bit transfer

8.1.1.1 START and STOP conditions

Both data and clock lines remain HIGH when the bus is not busy. A HIGH-to-LOW transition of the data line while the clock is HIGH is defined as the START condition (S); see [Figure 12](#). A LOW-to-HIGH transition of the data line while the clock is HIGH is defined as the STOP condition (P).

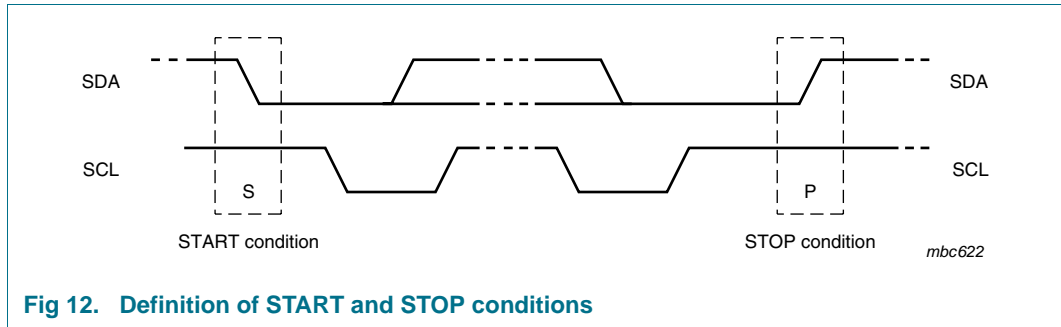

Fig 12. Definition of START and STOP conditions

8.1.2 System configuration

A device generating a message is a transmitter; a device receiving a message is a receiver. The device that controls the message is the master and the devices which are controlled by the master are the slaves; see [Figure 13](#).

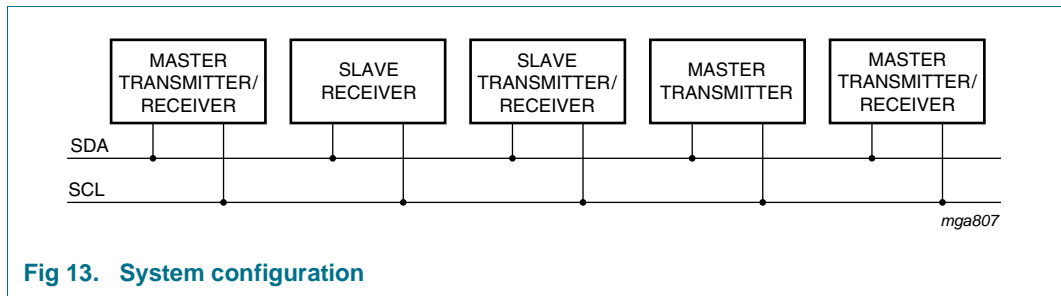

Fig 13. System configuration

8.1.3 Acknowledge

The number of data bytes transferred between the START and STOP conditions from transmitter to receiver is unlimited. Each byte of eight bits is followed by an acknowledge cycle.

- A slave receiver, which is addressed, must generate an acknowledge after the reception of each byte.
- A master receiver must generate an acknowledge after the reception of each byte that has been clocked out of the slave transmitter.
- The device that acknowledges must pull-down the SDA line during the acknowledge clock pulse, so that the SDA line is stable LOW during the HIGH period of the acknowledge related clock pulse (set-up and hold times must be taken into consideration).
- A master receiver must signal an end of data to the transmitter by not generating an acknowledge on the last byte that has been clocked out of the slave. In this event, the transmitter must leave the data line HIGH to enable the master to generate a STOP condition.

Acknowledgement on the I²C-bus is illustrated in [Figure 14](#).

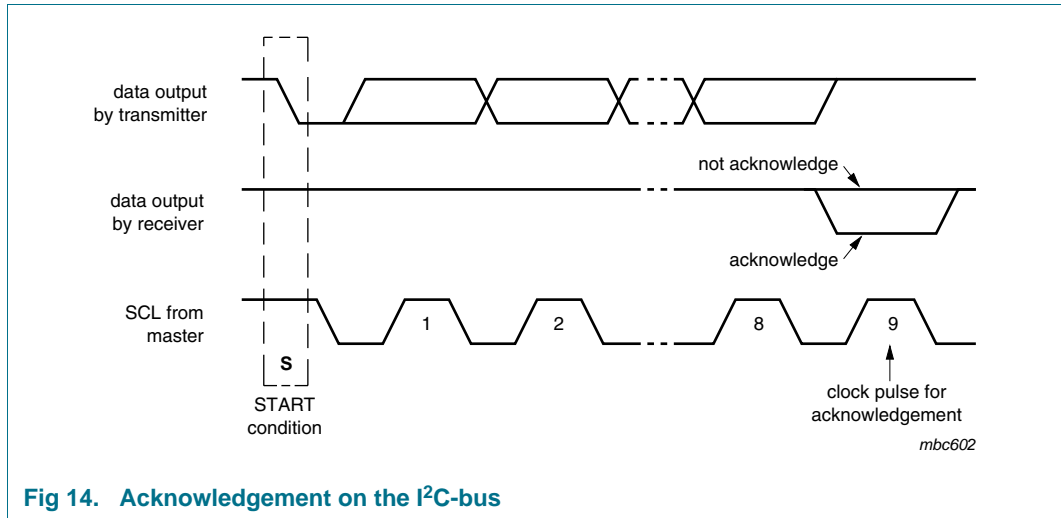

Fig 14. Acknowledgement on the I²C-bus

8.1.4 I²C-bus controller

The PCF8533 acts as an I²C-bus slave receiver. It does not initiate I²C-bus transfers or transmit data to an I²C-bus master receiver. The only data output from the PCF8533 are the acknowledge signals of the selected devices. Device selection depends on the I²C-bus slave address, the transferred command data and the hardware subaddress.

In single device applications, the hardware subaddress inputs A0, A1, and A2 are normally tied to V_{SS} which defines the hardware subaddress 0. In multiple device applications A0, A1, and A2 are tied to V_{SS} or V_{DD} using a binary coding scheme, so that no two devices with a common I²C-bus slave address have the same hardware subaddress.

8.1.5 Input filters

To enhance noise immunity in electrically adverse environments, RC low-pass filters are provided on the SDA and SCL lines.

8.1.6 I²C-bus protocol

Two I²C-bus slave addresses (0111 000 and 0111 001) are reserved for the PCF8533. The least significant bit of the slave address is bit R/W. The PCF8533 is a write-only device. It will not respond to a read access, so this bit should always be logic 0. The second bit of the slave address is defined by the level tied at input SA0. Two displays controlled by PCF8533 can be recognized on the same I²C-bus which allows:

- Up to 16 PCF8533s on the same I²C-bus for very large LCD applications
- The use of two types of LCD multiplex drive mode on the same I²C-bus

The I²C-bus protocol is shown in [Figure 15](#). The sequence is initiated with a START condition (S) from the I²C-bus master which is followed by one of the available PCF8533 slave addresses. All PCF8533s with the same SA0 level acknowledge in parallel to the slave address. All PCF8533s with the alternative SA0 level ignore the whole I²C-bus transfer.

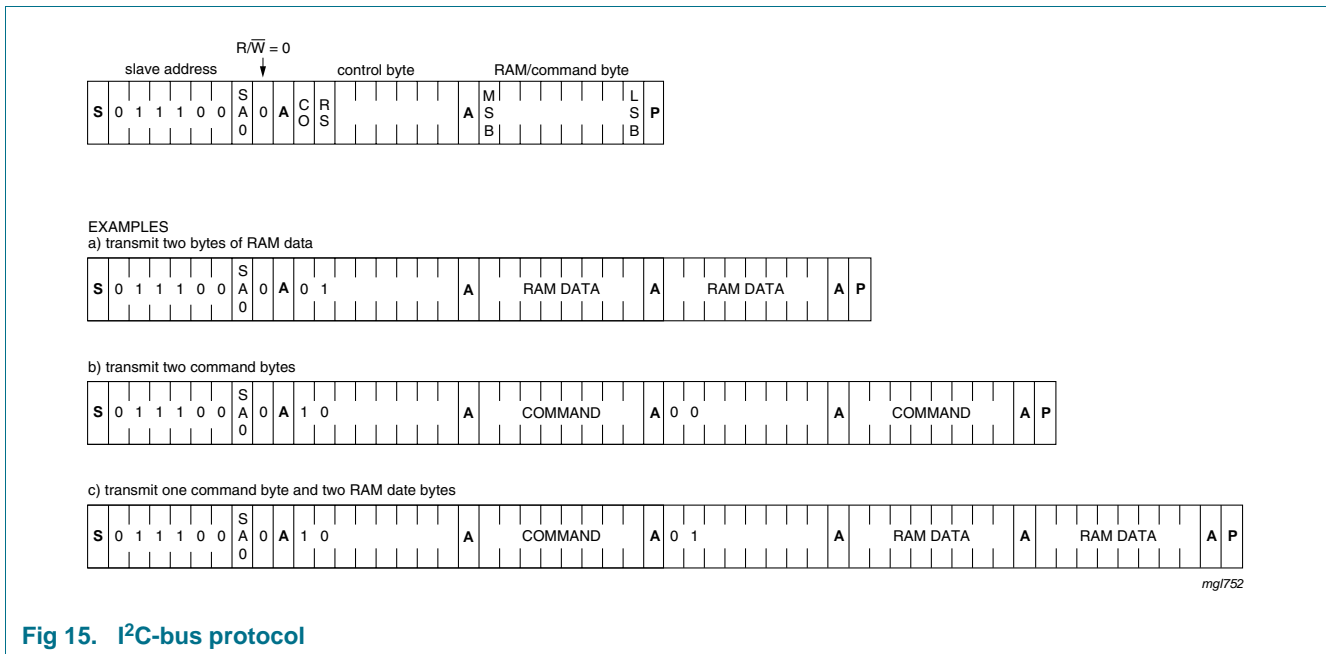

After acknowledgement, the control byte is sent defining if the next byte is a RAM or command information. The control byte also defines if the next byte is a control byte or further RAM or command data (see [Figure 16](#) and [Table 8](#)). In this way it is possible to configure the device and then fill the display RAM with little overhead.

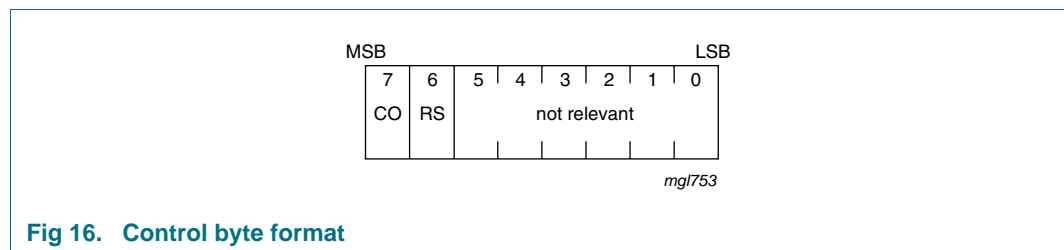

Table 8. Control byte description

Bit	Symbol	Value	Description
7	CO		continue bit
		0	last control byte
		1	control bytes continue
6	RS		register selection
		0	command register
		1	data register
5 to 0	-		not relevant

The command bytes and control bytes are also acknowledged by all addressed PCF8533s connected to the bus.

The display bytes are stored in the display RAM at the address specified by the data pointer and the subaddress counter; see [Section 7.11](#) and [Section 7.12](#).

The acknowledgement after each byte is made only by the (A0, A1, and A2) addressed PCF8533. After the last (display) byte, the I²C-bus master asserts a STOP condition (P). Alternatively a START may be asserted to RESTART an I²C-bus access.

8.2 Command decoder

The command decoder identifies command bytes that arrive on the I²C-bus. The five commands available to the PCF8533 are defined in [Table 9](#).

Table 9. Definition of commands

Command	Operation code									Reference
mode-set	1	1	0	0	E	B	M1	M0		Table 10
load-data-pointer	0	P6	P5	P4	P3	P2	P1	P0		Table 11
device-select	1	1	1	0	0	A2	A1	A0		Table 12
bank-select	1	1	1	1	1	0	I	O		Table 13
blink-select	1	1	1	1	0	A	BF1	BF0		Table 14

Table 10. Mode-set command bit description

Bit	Symbol	Value	Description
7 to 4	-	1100	fixed value
3	E		display status
			the possibility to disable the display allows implementation of blinking under external control
		0	disabled (blank)
		1	enabled
2	B		LCD bias configuration
		0	1/3 bias
		1	1/2 bias
1 to 0	M[1:0]		LCD drive mode selection
		01	static; 1 backplane
		10	1:2 multiplex; 2 backplanes
		11	1:3 multiplex; 3 backplanes
		00	1:4 multiplex; 4 backplanes

Table 11. Load-data-pointer command bit description

See [Section 7.11](#).

Bit	Symbol	Value	Description
7	-	0	fixed value
6 to 0	P[6:0]	0000000 to 1001111	immediate data 7-bit binary value of 0 to 79, transferred to the data pointer to define one of 80 display RAM addresses

Table 12. Device-select command bit description

See [Section 7.12](#).

Bit	Symbol	Value	Description
7 to 3	-	11100	fixed value
2 to 0	A[2:0]	000 to 111	immediate data 3-bit binary value of 0 to 7, transferred to the subaddress counter to define one of 8 hardware subaddresses

Table 13. Bank-select command bit description^[1]

See [Section 7.10](#), [Section 7.11](#), [Section 7.13](#), [Section 7.14](#) and [Section 7.12](#).

Bit	Symbol	Value	Description	
			Static	1:2 multiplex
7 to 2	-	111110	fixed value	
1	I		Input bank selection: storage of arriving display data	
		0	RAM bit 0	RAM bits 0 and 1
		1	RAM bit 2	RAM bits 2 and 3
0	O		Output bank selection: retrieval of LCD display data	
		0	RAM bit 0	RAM bits 0 and 1
		1	RAM bit 2	RAM bits 2 and 3

[1] The bank-select command has no effect in 1:3 or 1:4 multiplex drive modes.

Table 14. Blink-select command bit description

See [Section 7.15](#).

Bit	Symbol	Value	Description
7 to 3	-	11110	fixed value
2	A		blink mode selection^[1]
		0	normal blinking
		1	blinking by alternating display RAM banks
1 to 0	BF[1:0]		blink mode selection^[2]
		00	off
		01	1
		10	2
		11	3

[1] Only normal blinking can be selected in multiplexer 1:3 or 1:4 drive modes.

[2] For the blink frequency see [Table 7](#)

8.3 Display controller

The display controller executes the commands identified by the command decoder. It contains the device's status registers and co-ordinates their effects. The display controller is also responsible for loading display data into the display RAM as required by the filling order.

9. Internal circuitry

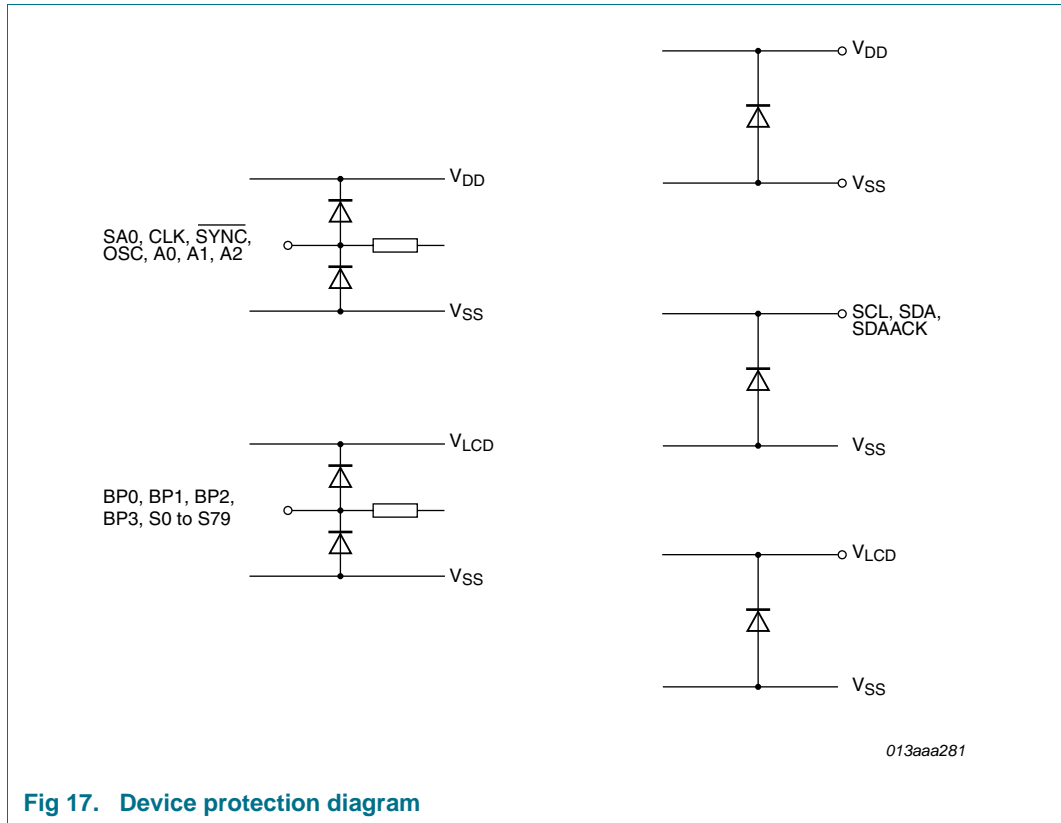

Fig 17. Device protection diagram

10. Limiting values

CAUTION



Static voltages across the liquid crystal display can build up when the LCD supply voltage (V_{LCD}) is on while the IC supply voltage (V_{DD}) is off, or vice versa. This may cause unwanted display artifacts. To avoid such artifacts, V_{LCD} and V_{DD} must be applied or removed together.

Table 15. Limiting values

In accordance with the Absolute Maximum Rating System (IEC 60134).

Symbol	Parameter	Conditions	Min	Max	Unit	
V_{DD}	supply voltage		-0.5	+6.5	V	
V_{LCD}	LCD supply voltage		-0.5	+7.5	V	
$V_{i(n)}$	voltage on any input	V_{DD} related inputs	-0.5	+6.5	V	
$V_{o(n)}$	voltage on any output	V_{LCD} related outputs	-0.5	+7.5	V	
I_I	input current		-10	+10	mA	
I_O	output current		-10	+10	mA	
I_{DD}	supply current		-50	+50	mA	
I_{SS}	ground supply current		-50	+50	mA	
$I_{DD(LCD)}$	LCD supply current		-50	+50	mA	
P_{tot}	total power dissipation		-	400	mW	
P/out	power dissipation per output		-	100	mW	
V_{ESD}	electrostatic discharge voltage	HBM	[1]	-	±5000	V
		MM	[2]	-	±200	V
I_{lu}	latch-up current		[3]	-	100	mA
T_{stg}	storage temperature		[4]	-65	+150	°C
T_{amb}	ambient temperature			-40	+85	°C

[1] Pass level; Human Body Model (HBM), according to [Ref. 6 "JESD22-A114"](#)

[2] Pass level; Machine Model (MM), according to [Ref. 7 "JESD22-A115"](#).

[3] Pass level; latch-up testing according to [Ref. 8 "JESD78"](#) at maximum ambient temperature ($T_{amb(max)}$).

[4] According to the NXP store and transport requirements (see [Ref. 10 "NX3-00092"](#)) the devices have to be stored at a temperature of +8 °C to +45 °C and a humidity of 25 % to 75 %. For long term storage products deviant conditions are described in that document.

11. Static characteristics

Table 16. Static characteristics
 $V_{DD} = 1.8\text{ V to }5.5\text{ V}; V_{SS} = 0\text{ V}; V_{LCD} = 2.5\text{ V to }6.5\text{ V}; T_{amb} = -40\text{ }^{\circ}\text{C to }+85\text{ }^{\circ}\text{C};$ unless otherwise specified.

Symbol	Parameter	Conditions	Min	Typ	Max	Unit	
Supplies							
V_{DD}	supply voltage		1.8	-	5.5	V	
V_{LCD}	LCD supply voltage		2.5	-	6.5	V	
V_{POR}	power-on reset voltage		1.0	1.3	1.6	V	
I_{DD}	supply current	$f_{clk(ext)} = 1536\text{ Hz}$	[1][2]	-	20	μA	
$I_{DD(LCD)}$	LCD supply current	$f_{clk(ext)} = 1536\text{ Hz}$	[1][3]	-	60	μA	
Logic							
V_I	input voltage		$V_{SS} - 0.5$	-	$V_{DD} + 0.5$	V	
V_{IL}	LOW-level input voltage	on pins CLK, SYNC, OSC, A0 to A2, SA0	V_{SS}	-	$0.3V_{DD}$	V	
V_{IH}	HIGH-level input voltage	on pins CLK, SYNC, OSC, A0 to A2, SA0	$0.7V_{DD}$	-	V_{DD}	V	
V_O	output voltage		-0.5	-	$V_{DD} + 0.5$	V	
V_{OH}	HIGH-level output voltage		$0.8V_{DD}$	-	-	V	
V_{OL}	LOW-level output voltage		-	-	$0.2V_{DD}$	V	
I_L	leakage current	on pins OSC, CLK, SCL, SDA, A0 to A2, SA0; $V_I = V_{DD}$ or V_{SS}	-1	-	+1	μA	
I_{OL}	LOW-level output current	output sink current; on pins CLK, SYNC; $V_{OL} = 0.4\text{ V}; V_{DD} = 5\text{ V}$	1	-	-	mA	
I_{OH}	HIGH-level output current	output source current; on pin CLK; $V_{OH} = 4.6\text{ V}; V_{DD} = 5\text{ V}$	1	-	-	mA	
C_I	input capacitance		[4]	-	7	pF	
I²C-bus							
Input on pins SDA and SCL							
V_I	input voltage		$V_{SS} - 0.5$	-	5.5	V	
V_{IL}	LOW-level input voltage		V_{SS}	-	$0.3V_{DD}$	V	
V_{IH}	HIGH-level input voltage		$0.7V_{DD}$	-	5.5	V	
I_{LI}	input leakage current	$V_I = V_{DD}$ or V_{SS}	-1	-	+1	μA	
C_I	input capacitance		[4]	-	7	pF	
$I_{OL(SDA)}$	LOW-level output current on pin SDA	$V_{OL} = 0.4\text{ V}; V_{DD} = 5\text{ V}$	3	-	-	mA	
LCD outputs							
Output pins BP0, BP1, BP2 and BP3							
V_{BP}	voltage on pin BP	$C_{bpl} = 35\text{ nF}$	[5]	-100	-	+100	mV
R_{BP}	resistance on pin BP	$V_{LCD} = 5\text{ V}$	[6]	-	1.5	10	k Ω

Table 16. Static characteristics ...continued

$V_{DD} = 1.8\text{ V to }5.5\text{ V}$; $V_{SS} = 0\text{ V}$; $V_{LCD} = 2.5\text{ V to }6.5\text{ V}$; $T_{amb} = -40\text{ }^{\circ}\text{C to }+85\text{ }^{\circ}\text{C}$; unless otherwise specified.

Symbol	Parameter	Conditions	Min	Typ	Max	Unit
Output pins S0 to S79						
V_S	voltage on pin S	$C_{sgm} = 5\text{ nF}$	[7] -100	-	+100	mV
R_S	resistance on pin S	$V_{LCD} = 5\text{ V}$	[6] -	6.0	13.5	$k\Omega$

- [1] LCD outputs are open-circuit; inputs at V_{SS} or V_{DD} ; external clock with 50 % duty factor; I²C-bus inactive.
- [2] For typical values, see [Figure 18](#).
- [3] For typical values, see [Figure 19](#).
- [4] Not tested, design specification only.
- [5] C_{bpl} = backplane capacitance.
- [6] Outputs measured individually and sequentially.
- [7] C_{sgm} = segment capacitance.

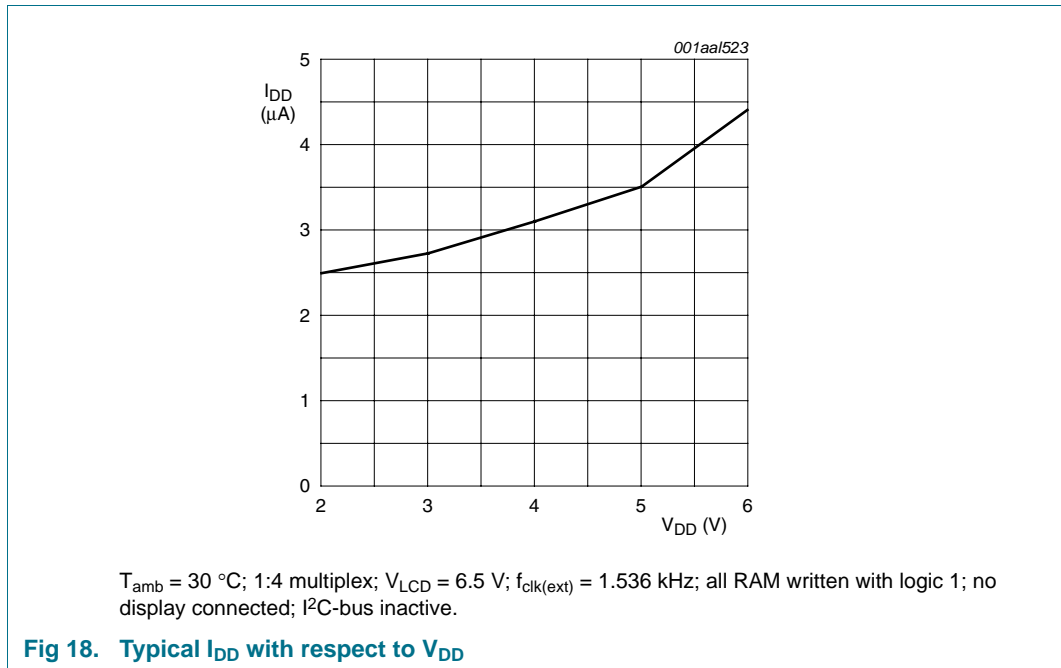

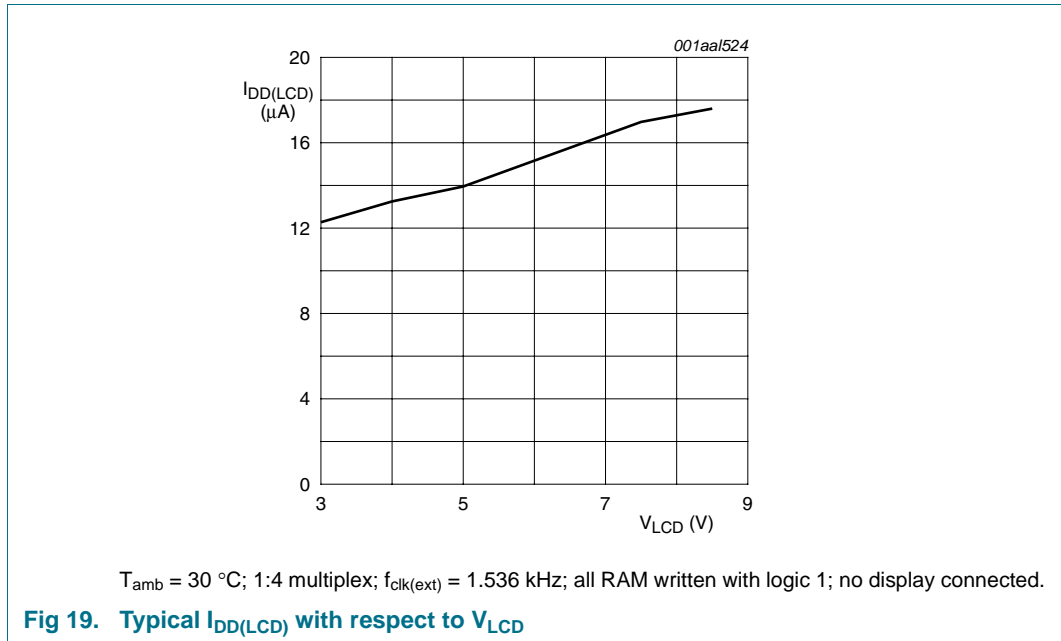

12. Dynamic characteristics

Table 17. Dynamic characteristics

V_{DD} = 1.8 V to 5.5 V; V_{SS} = 0 V; V_{LCD} = 2.5 V to 6.5 V; T_{amb} = -40 °C to +85 °C; unless otherwise specified.

Symbol	Parameter	Conditions	Min	Typ	Max	Unit
Clock						
f _{clk(int)}	internal clock frequency		[1][3] 960	1536	3046	Hz
f _{clk(ext)}	external clock frequency		[1][3] 797	1536	3046	Hz
t _{clk(H)}	HIGH-level clock time		130	-	-	µs
t _{clk(L)}	LOW-level clock time		130	-	-	µs
t _r	rise time		-	-	-	ns
t _f	fall time		-	-	-	ns
Synchronization: input pin SYNC						
t _{PD(SYNC_N)}	$\overline{\text{SYNC}}$ propagation delay		-	30	-	ns
t _{SYNC_NL}	$\overline{\text{SYNC}}$ LOW time		1	-	-	µs
Outputs: pins BP0 to BP3 and S0 to S79						
t _{PD(drv)}	driver propagation delay	V _{LCD} = 5 V	-	-	30	µs
I²C-bus: timing[2]; see Figure 21						
Pin SCL						
f _{SCL}	SCL clock frequency		-	-	400	kHz
t _{LOW}	LOW period of the SCL clock		1.3	-	-	µs
t _{HIGH}	HIGH period of the SCL clock		0.6	-	-	µs
Pin SDA						
t _{SU;DAT}	data set-up time		100	-	-	ns
t _{HD;DAT}	data hold time		0	-	-	ns

Table 17. Dynamic characteristics ...continued

$V_{DD} = 1.8\text{ V to }5.5\text{ V}$; $V_{SS} = 0\text{ V}$; $V_{LCD} = 2.5\text{ V to }6.5\text{ V}$; $T_{amb} = -40\text{ }^{\circ}\text{C to }+85\text{ }^{\circ}\text{C}$; unless otherwise specified.

Symbol	Parameter	Conditions	Min	Typ	Max	Unit
Pins SCL and SDA						
t_{BUF}	bus free time between a STOP and START condition		1.3	-	-	μs
$t_{SU;STO}$	set-up time for STOP condition		0.6	-	-	μs
$t_{HD;STA}$	hold time (repeated) START condition		0.6	-	-	μs
$t_{SU;STA}$	set-up time for a repeated START condition		0.6	-	-	μs
t_r	rise time of both SDA and SCL signals		-	-	0.3	μs
t_f	fall time of both SDA and SCL signals		-	-	0.3	μs
C_b	capacitive load for each bus line		-	-	400	pF
$t_{w(\text{spike})}$	spike pulse width	on bus	-	-	50	ns

- [1] Typical output duty cycle of 50 %.
- [2] All timing values are valid within the operating supply voltage and ambient temperature range and are referenced to V_{IL} and V_{IH} with an input voltage swing of V_{SS} to V_{DD} .
- [3] The corresponding frame frequency is $f_{fr} = f_{clk}/24$.

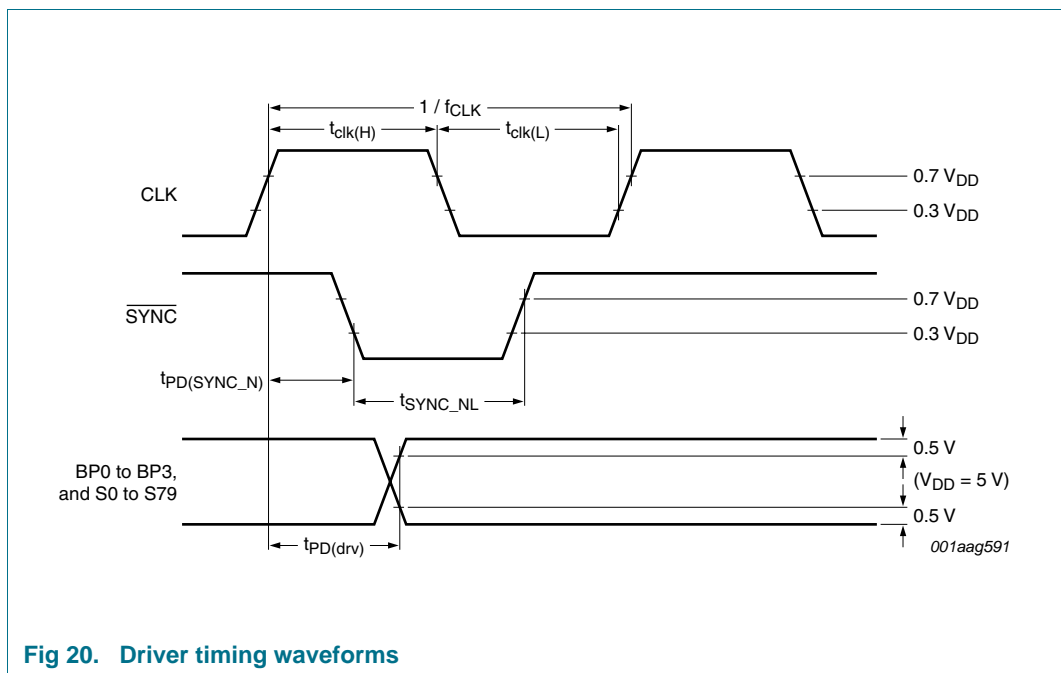

Fig 20. Driver timing waveforms

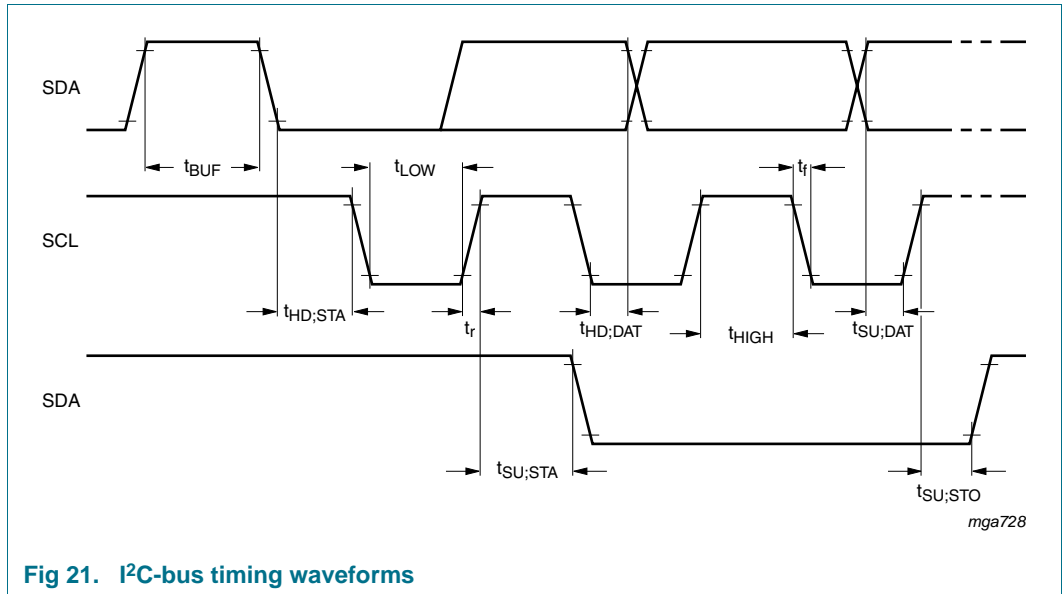

Fig 21. I²C-bus timing waveforms

13. Application information

13.1 Cascaded operation

Large display configurations of up to sixteen PCF8533s can be recognized on the same I²C-bus by using the 3-bit hardware subaddress (A0, A1 and A2) and the programmable I²C-bus slave address (SA0).

Table 18. Addressing cascaded PCF8533

Cluster	Bit SA0	Pin A2	Pin A1	Pin A0	Device
1	0	0	0	0	0
		0	0	1	1
		0	1	0	2
		0	1	1	3
		1	0	0	4
		1	0	1	5
		1	1	0	6
		1	1	1	7
2	1	0	0	0	8
		0	0	1	9
		0	1	0	10
		0	1	1	11
		1	0	0	12
		1	0	1	13
		1	1	0	14
		1	1	1	15

Cascaded PCF8533s are synchronized. They can share the backplane signals from one of the devices in the cascade. Such an arrangement is cost-effective in large LCD applications since the backplane outputs of only one device need to be through-plated to the backplane electrodes of the display. The other PCF8533s of the cascade contribute additional segment outputs but their backplane outputs are left open-circuit (see [Figure 22](#)).

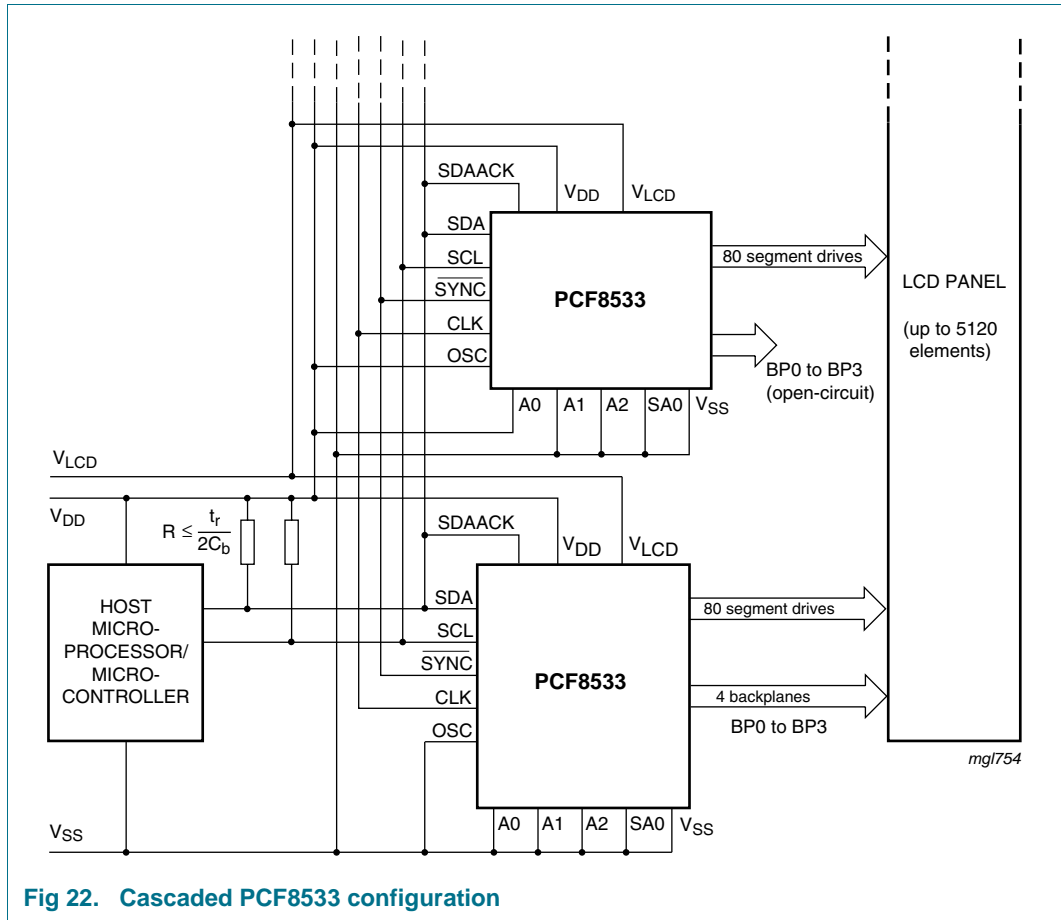
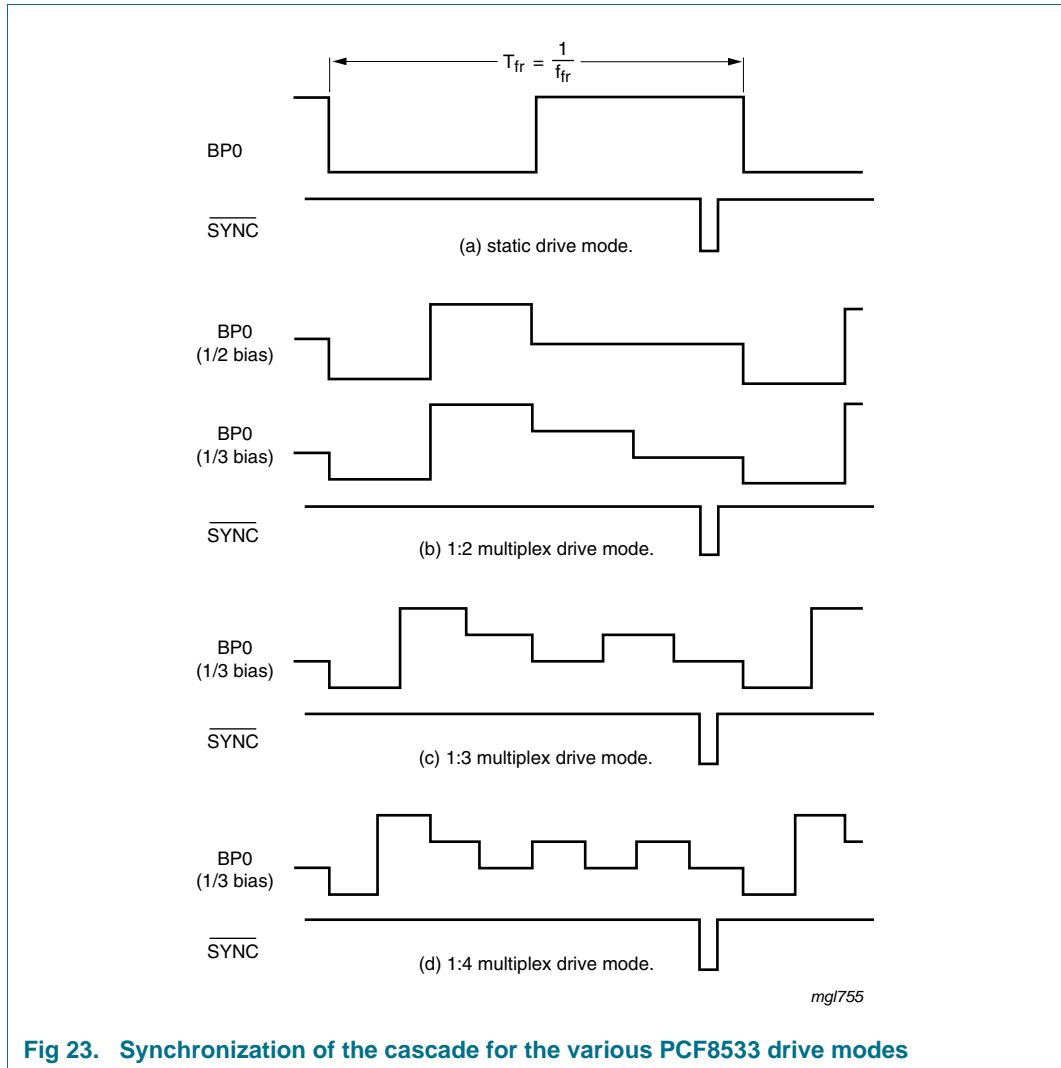

Fig 22. Cascaded PCF8533 configuration

The SYNC line is provided to maintain the correct synchronization between all cascaded PCF8533s. This synchronization is guaranteed after the power-on reset. The only time that SYNC is likely to be needed is if synchronization is accidentally lost (e.g. by noise in adverse electrical environments, or by the definition of a multiplex mode when PCF8533s with different SA0 levels are cascaded).

SYNC is organized as an input/output pin; the output selection being realized as an open-drain driver with an internal pull-up resistor. A PCF8533 asserts the SYNC line at the onset of its last active backplane signal and monitors the SYNC line at all other times. Should synchronization in the cascade be lost, it will be restored by the first PCF8533 to assert SYNC. The timing relationships between the backplane waveforms and the SYNC signal for the various drive modes of the PCF8533 are shown in [Figure 23](#).



The contact resistance between the $\overline{\text{SYNC}}$ pins of cascaded devices must be controlled. If the resistance is too high then the device will not be able to synchronize properly. This is particularly applicable to COG applications. [Table 19](#) shows the limiting values for contact resistance.

Table 19. $\overline{\text{SYNC}}$ contact resistance

Number of devices	Maximum contact resistance
2	6000 Ω
3 to 5	2200 Ω
6 to 10	1200 Ω
11 to 16	700 Ω

14. Bare die description

14.1 Gold bump hardness

Table 20. Gold bump hardness

Type number	Min	Max	Unit ^[1]
PCF8533U/2/F2	60	120	HV
PCF8533U/2DA/2	35	80	HV

[1] Pressure of diamond head: 10 g to 50 g.

14.2 Alignment marks

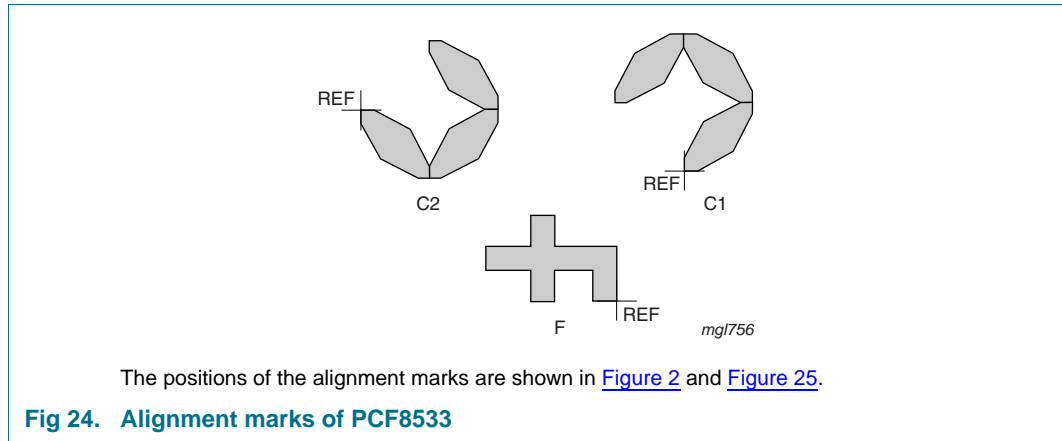

Table 21. Alignment mark locations

Symbol	X (μm)	Y (μm)
C1	2300.5	55.0
C2	-2320.2	107.0
F	-2208.3	-165.4

14.3 Bump locations

Table 22. Bump locations

All x/y coordinates represent the position of the centre of each bump with respect to the center (x/y = 0) of the chip; see [Figure 25](#).

Symbol	Bump	X (μm)	Y (μm)	Description
SDAACK	1	-1079.20	-594.40	^[1] I ² C-bus acknowledge output
SDA	2	-839.20	-594.40	^[1] I ² C-bus serial data input
SDA	3	-759.20	-594.40	^[1]
SCL	4	-599.20	-594.40	I ² C-bus serial clock input
SCL	5	-519.20	-594.40	
CLK	6	-414.80	-594.40	clock input/output
V _{DD}	7	-284.80	-594.40	supply voltage
$\overline{\text{SYNC}}$	8	4.20	-594.40	cascade synchronization input/output
OSC	9	119.20	-594.40	oscillator select

Table 22. Bump locations

All x/y coordinates represent the position of the centre of each bump with respect to the center (x/y = 0) of the chip; see [Figure 25](#).

Symbol	Bump	X (μm)	Y (μm)	Description
A0	10	249.20	-594.40	subaddress input
A1	11	379.20	-594.40	
A2	12	581.20	-594.40	
SA0	13	711.20	-594.40	I ² C-bus slave address input; bit 0
V _{SS}	14	841.20	-594.40	ground supply voltage
V _{LCD}	15	1099.60	-594.40	LCD supply voltage
BP2	16	1277.60	-594.40	LCD backplane output
BP0	17	1357.60	-594.40	
S0	18	1437.60	-594.40	
S1	19	1517.60	-594.40	
S2	20	1597.60	-594.40	
S3	21	1677.60	-594.40	
S4	22	1757.60	-594.40	
S5	23	1837.60	-594.40	
S6	24	1917.60	-594.40	
S7	25	1997.60	-594.40	
S8	26	2077.60	-594.40	
S9	27	2157.60	-594.40	
S10	28	2237.60	-594.40	
S11	29	2317.60	-594.40	LCD segment output
S12	30	2357.60	594.40	
S13	31	2277.60	594.40	
S14	32	2197.60	594.40	
S15	33	2117.60	594.40	
S16	34	2037.60	594.40	
S17	35	1957.60	594.40	
S18	36	1877.60	594.40	
S19	37	1797.60	594.40	
S20	38	1717.60	594.40	
S21	39	1637.60	594.40	
S22	40	1557.60	594.40	
S23	41	1477.60	594.40	
S24	42	1317.60	594.40	
S25	43	1237.60	594.40	
S26	44	1157.60	594.40	
S27	45	1077.60	594.40	
S28	46	997.60	594.40	
S29	47	917.60	594.40	

Table 22. Bump locations

All x/y coordinates represent the position of the centre of each bump with respect to the center (x/y = 0) of the chip; see [Figure 25](#).

Symbol	Bump	X (μm)	Y (μm)	Description
S30	48	837.60	594.40	LCD segment output
S31	49	757.60	594.40	
S32	50	677.60	594.40	
S33	51	597.60	594.40	
S34	52	437.60	594.40	
S35	53	357.60	594.40	
S36	54	277.60	594.40	
S37	55	197.60	594.40	
S38	56	117.60	594.40	
S39	57	37.60	594.40	
S40	58	-42.40	594.40	
S41	59	-122.40	594.40	
S42	60	-202.40	594.40	
S43	61	-282.40	594.40	
S44	62	-362.40	594.40	
S45	63	-442.40	594.40	
S46	64	-602.40	594.40	
S47	65	-682.40	594.40	
S48	66	-762.40	594.40	
S49	67	-842.40	594.40	
S50	68	-922.40	594.40	
S51	69	-1002.40	594.40	
S52	70	-1082.40	594.40	
S53	71	-1162.40	594.40	
S54	72	-1242.40	594.40	
S55	73	-1322.40	594.40	
S56	74	-1402.40	594.40	
S57	75	-1562.40	594.40	
S58	76	-1642.40	594.40	
S59	77	-1722.40	594.40	
S60	78	-1802.40	594.40	
S61	79	-1882.40	594.40	
S62	80	-1962.40	594.40	
S63	81	-2042.40	594.40	
S64	82	-2122.40	594.40	
S65	83	-2202.40	594.40	
S66	84	-2282.40	594.40	

Table 22. Bump locations

All x/y coordinates represent the position of the centre of each bump with respect to the center (x/y = 0) of the chip; see [Figure 25](#).

Symbol	Bump	X (μm)	Y (μm)	Description
S67	85	-2362.40	594.40	LCD segment output
S68	86	-2322.40	-594.40	
S69	87	-2242.40	-594.40	
S70	88	-2162.40	-594.40	
S71	89	-2082.40	-594.40	
S72	90	-2002.40	-594.40	
S73	91	-1922.40	-594.40	
S74	92	-1842.40	-594.40	
S75	93	-1762.40	-594.40	
S76	94	-1682.40	-594.40	
S77	95	-1602.40	-594.40	
S78	96	-1522.40	-594.40	
S79	97	-1442.40	-594.40	
BP3	98	-1362.40	-594.40	LCD backplane output
BP1	99	-1282.40	-594.40	
D1	-	2469.70	-594.40	[2] dummy bump
D2	-	2549.70	-594.40	
D3	-	2517.60	594.40	
D4	-	2437.60	594.40	
D5	-	-2442.30	594.40	
D6	-	-2522.30	594.40	[2]
D7	-	-2554.40	-594.40	
D8	-	-2474.40	-594.40	

[1] For most applications SDA and SDAACK are shorted together; see [Section 8.1](#).

[2] The dummy bumps are connected to the adjacent segments but are not tested.

15. Bare die outline

Bare die; 99 bumps; 5.28 x 1.4 x 0.38 mm

PCF8533-2

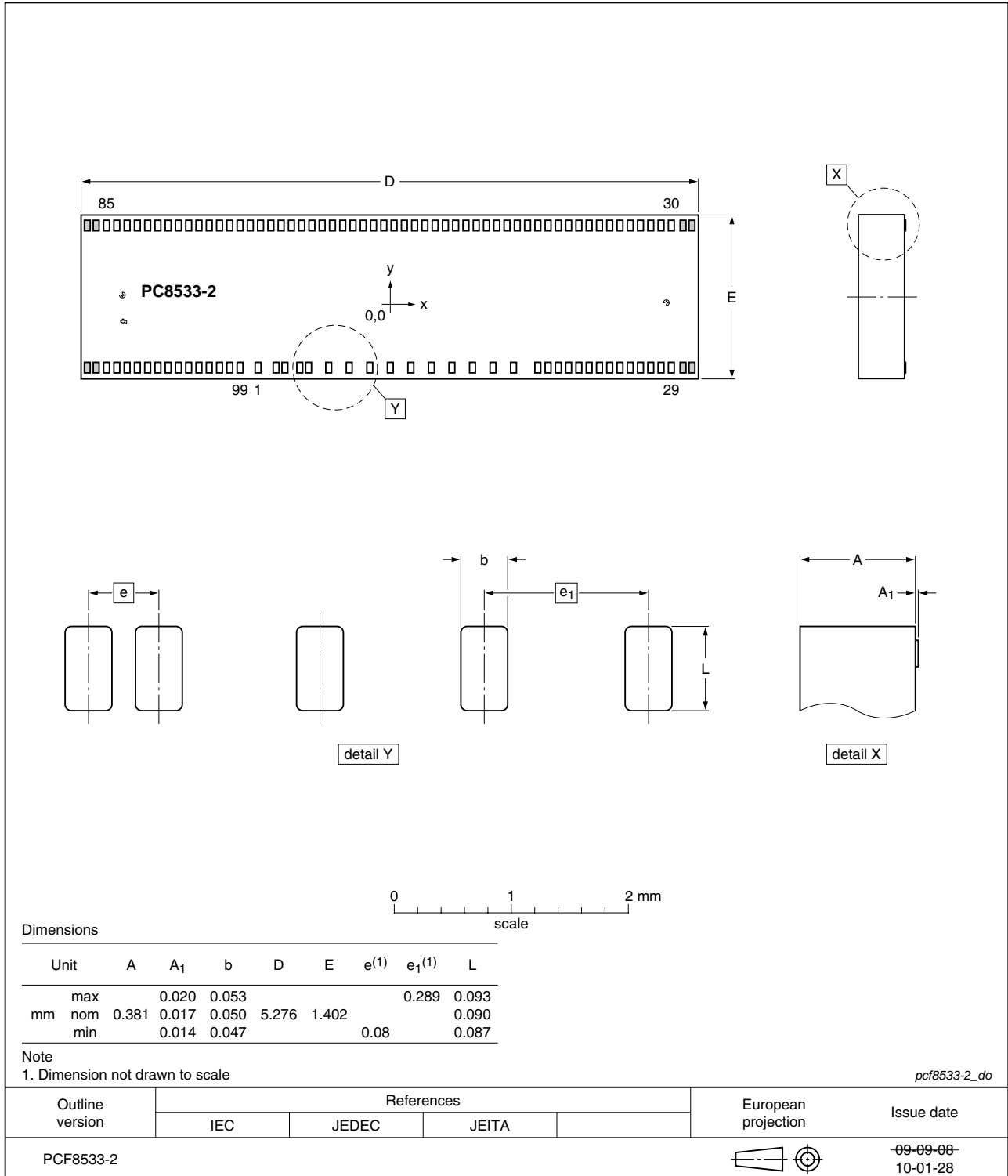

Fig 25. Bare die outline of PCF8533-2

16. Handling information

All input and output pins are protected against ElectroStatic Discharge (ESD) under normal handling. When handling Metal-Oxide Semiconductor (MOS) devices ensure that all normal precautions are taken as described in *JESD625-A*, *IEC 61340-5* or equivalent standards.

17. Packing information

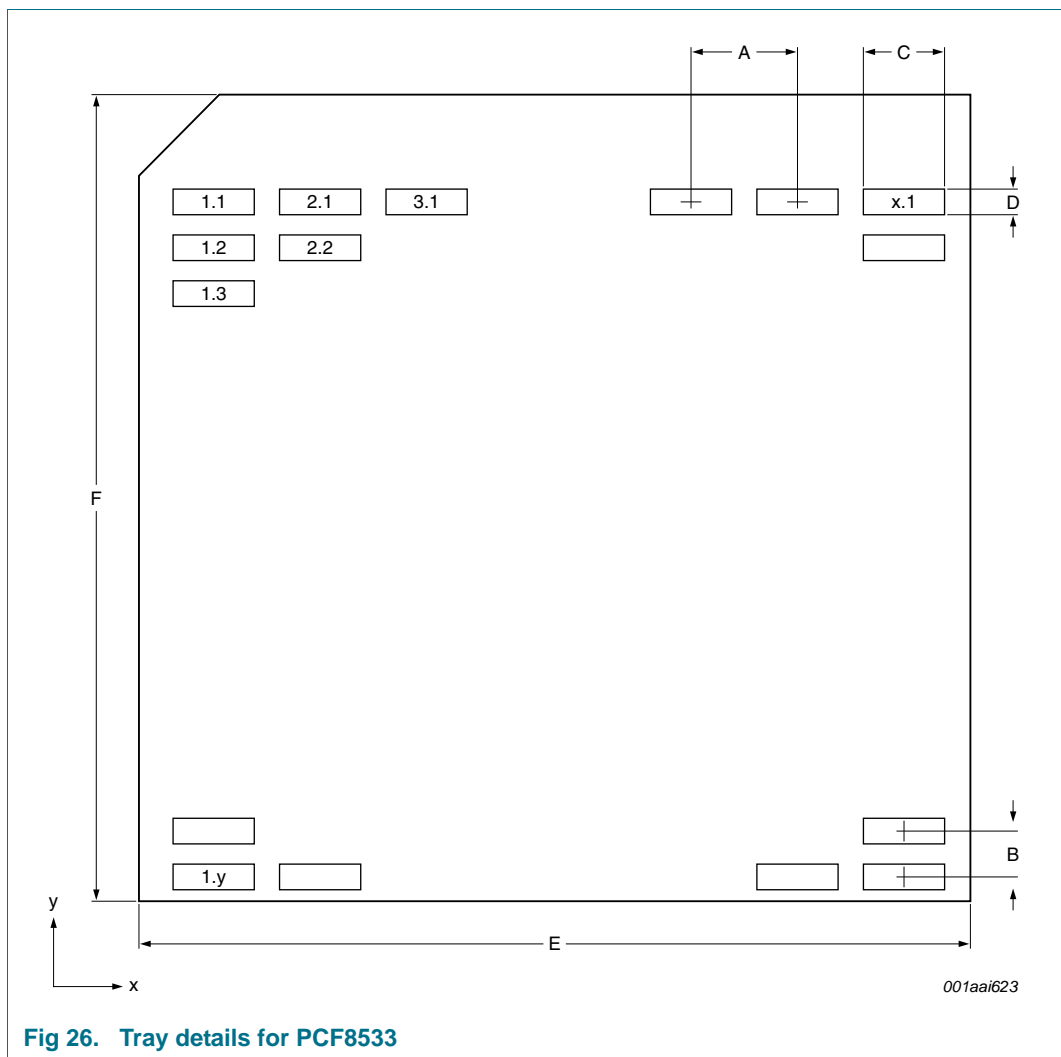

Fig 26. Tray details for PCF8533

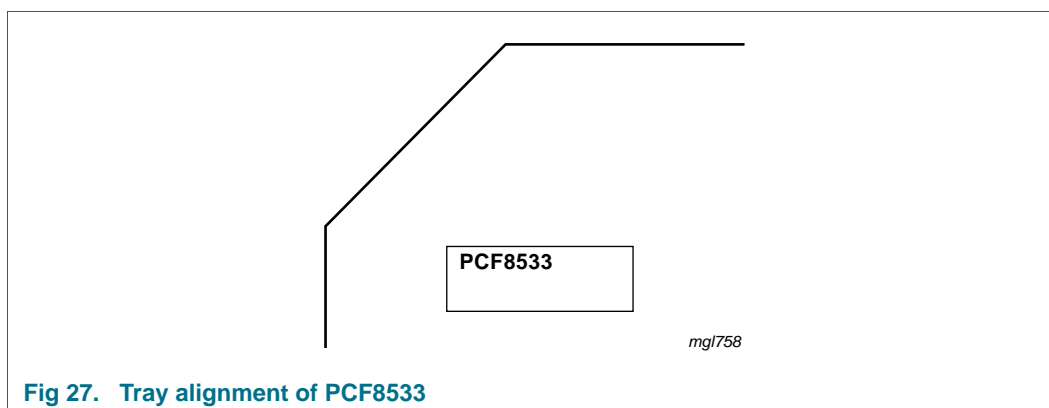

Fig 27. Tray alignment of PCF8533

Table 23. Tray dimensions

See [Figure 26](#).

Symbol	Description	Value
A	pocket pitch in x direction	7.37 mm
B	pocket pitch in y direction	3.68 mm
C	pocket width in x direction	5.50 mm
D	pocket width in y direction	1.60 mm
E	tray width in x direction	50.8 mm
F	tray width in y direction	50.8 mm
N	number of pockets, x direction	6
M	number of pockets, y direction	12

The orientation of the IC in a pocket is indicated by the position of the IC type name on the die surface with respect to the chamfer on the upper left corner of the tray. Refer to [Figure 25](#) for the orientation and position of the type name on the die surface.

18. Abbreviations

Table 24. Abbreviations

Acronym	Description
CDM	Charged Device Model
CMOS	Complementary Metal-Oxide Semiconductor
ESD	ElectroStatic Discharge
HBM	Human Body Model
IC	Integrated Circuit
LCD	Liquid Crystal Display
MM	Machine Model
RAM	Random Access Memory
TTL	Transistor-Transistor Logic

19. References

- [1] **AN10170** — Design guidelines for COG modules with NXP monochrome LCD drivers
- [2] **AN10706** — Handling bare die
- [3] **IEC 60134** — Rating systems for electronic tubes and valves and analogous semiconductor devices
- [4] **IEC 61340-5** — Protection of electronic devices from electrostatic phenomena
- [5] **IPC/JEDEC J-STD-020D** — Moisture/Reflow Sensitivity Classification for Nonhermetic Solid State Surface Mount Devices
- [6] **JESD22-A114** — Electrostatic Discharge (ESD) Sensitivity Testing Human Body Model (HBM)
- [7] **JESD22-A115** — Electrostatic Discharge (ESD) Sensitivity Testing Machine Model (MM)
- [8] **JESD78** — IC Latch-Up Test
- [9] **JESD625-A** — Requirements for Handling Electrostatic-Discharge-Sensitive (ESDS) Devices
- [10] **NX3-00092** — NXP store and transport requirements
- [11] **UM10204** — I²C-bus specification and user manual

20. Revision history

Table 25. Revision history

Document ID	Release date	Data sheet status	Change notice	Supersedes
PCF8533_4	20100305	Product data sheet	-	PCF8533_3
Modifications:	<ul style="list-style-type: none"> • The format of this data sheet has been redesigned to comply with the new identity guidelines of NXP Semiconductors. • Legal texts have been adapted to the new company name where appropriate. • Added product with soft bumps 			
PCF8533_3	20080424	Product data sheet	-	PCF8533_2
Modifications:	<ul style="list-style-type: none"> • The format of this data sheet has been redesigned to comply with the new identity guidelines of NXP Semiconductors. • Legal texts have been adapted to the new company name where appropriate. • Miscellaneous changes to text, tables and graphics throughout • "Soldering" section deleted 			
PCF8533_2	19990730	Product specification	-	PCF8533_SDS_1
PCF8533_SDS_1	19990312	Product specification	-	-

21. Legal information

21.1 Data sheet status

Document status ^{[1][2]}	Product status ^[3]	Definition
Objective [short] data sheet	Development	This document contains data from the objective specification for product development.
Preliminary [short] data sheet	Qualification	This document contains data from the preliminary specification.
Product [short] data sheet	Production	This document contains the product specification.

[1] Please consult the most recently issued document before initiating or completing a design.

[2] The term 'short data sheet' is explained in section "Definitions".

[3] The product status of device(s) described in this document may have changed since this document was published and may differ in case of multiple devices. The latest product status information is available on the Internet at URL <http://www.nxp.com>.

21.2 Definitions

Draft — The document is a draft version only. The content is still under internal review and subject to formal approval, which may result in modifications or additions. NXP Semiconductors does not give any representations or warranties as to the accuracy or completeness of information included herein and shall have no liability for the consequences of use of such information.

Short data sheet — A short data sheet is an extract from a full data sheet with the same product type number(s) and title. A short data sheet is intended for quick reference only and should not be relied upon to contain detailed and full information. For detailed and full information see the relevant full data sheet, which is available on request via the local NXP Semiconductors sales office. In case of any inconsistency or conflict with the short data sheet, the full data sheet shall prevail.

Product specification — The information and data provided in a Product data sheet shall define the specification of the product as agreed between NXP Semiconductors and its customer, unless NXP Semiconductors and customer have explicitly agreed otherwise in writing. In no event however, shall an agreement be valid in which the NXP Semiconductors product is deemed to offer functions and qualities beyond those described in the Product data sheet.

21.3 Disclaimers

Limited warranty and liability — Information in this document is believed to be accurate and reliable. However, NXP Semiconductors does not give any representations or warranties, expressed or implied, as to the accuracy or completeness of such information and shall have no liability for the consequences of use of such information.

In no event shall NXP Semiconductors be liable for any indirect, incidental, punitive, special or consequential damages (including - without limitation - lost profits, lost savings, business interruption, costs related to the removal or replacement of any products or rework charges) whether or not such damages are based on tort (including negligence), warranty, breach of contract or any other legal theory.

Notwithstanding any damages that customer might incur for any reason whatsoever, NXP Semiconductors' aggregate and cumulative liability towards customer for the products described herein shall be limited in accordance with the *Terms and conditions of commercial sale* of NXP Semiconductors.

Right to make changes — NXP Semiconductors reserves the right to make changes to information published in this document, including without limitation specifications and product descriptions, at any time and without notice. This document supersedes and replaces all information supplied prior to the publication hereof.

Suitability for use — NXP Semiconductors products are not designed, authorized or warranted to be suitable for use in medical, military, aircraft, space or life support equipment, nor in applications where failure or

malfunction of an NXP Semiconductors product can reasonably be expected to result in personal injury, death or severe property or environmental damage. NXP Semiconductors accepts no liability for inclusion and/or use of NXP Semiconductors products in such equipment or applications and therefore such inclusion and/or use is at the customer's own risk.

Applications — Applications that are described herein for any of these products are for illustrative purposes only. NXP Semiconductors makes no representation or warranty that such applications will be suitable for the specified use without further testing or modification.

NXP Semiconductors does not accept any liability related to any default, damage, costs or problem which is based on a weakness or default in the customer application/use or the application/use of customer's third party customer(s) (hereinafter both referred to as "Application"). It is customer's sole responsibility to check whether the NXP Semiconductors product is suitable and fit for the Application planned. Customer has to do all necessary testing for the Application in order to avoid a default of the Application and the product. NXP Semiconductors does not accept any liability in this respect.

Limiting values — Stress above one or more limiting values (as defined in the Absolute Maximum Ratings System of IEC 60134) will cause permanent damage to the device. Limiting values are stress ratings only and (proper) operation of the device at these or any other conditions above those given in the Recommended operating conditions section (if present) or the Characteristics sections of this document is not warranted. Constant or repeated exposure to limiting values will permanently and irreversibly affect the quality and reliability of the device.

Terms and conditions of commercial sale — NXP Semiconductors products are sold subject to the general terms and conditions of commercial sale, as published at <http://www.nxp.com/profile/terms>, unless otherwise agreed in a valid written individual agreement. In case an individual agreement is concluded only the terms and conditions of the respective agreement shall apply. NXP Semiconductors hereby expressly objects to applying the customer's general terms and conditions with regard to the purchase of NXP Semiconductors products by customer.

No offer to sell or license — Nothing in this document may be interpreted or construed as an offer to sell products that is open for acceptance or the grant, conveyance or implication of any license under any copyrights, patents or other industrial or intellectual property rights.

Export control — This document as well as the item(s) described herein may be subject to export control regulations. Export might require a prior authorization from national authorities.

Non-automotive qualified products — Unless this data sheet expressly states that this specific NXP Semiconductors product is automotive qualified, the product is not suitable for automotive use. It is neither qualified nor tested in accordance with automotive testing or application requirements. NXP Semiconductors accepts no liability for inclusion and/or use of non-automotive qualified products in automotive equipment or applications.

In the event that customer uses the product for design-in and use in automotive applications to automotive specifications and standards, customer (a) shall use the product without NXP Semiconductors' warranty of the

product for such automotive applications, use and specifications, and (b) whenever customer uses the product for automotive applications beyond NXP Semiconductors' specifications such use shall be solely at customer's own risk, and (c) customer fully indemnifies NXP Semiconductors for any liability, damages or failed product claims resulting from customer design and use of the product for automotive applications beyond NXP Semiconductors' standard warranty and NXP Semiconductors' product specifications.

Bare die — All die are tested on compliance with their related technical specifications as stated in this data sheet up to the point of wafer sawing and are handled in accordance with the NXP Semiconductors storage and transportation conditions. If there are data sheet limits not guaranteed, these will be separately indicated in the data sheet. There are no post-packing tests performed on individual die or wafers.

NXP Semiconductors has no control of third party procedures in the sawing, handling, packing or assembly of the die. Accordingly, NXP Semiconductors assumes no liability for device functionality or performance of the die or systems after third party sawing, handling, packing or assembly of the die. It is the responsibility of the customer to test and qualify their application in which the die is used.

All die sales are conditioned upon and subject to the customer entering into a written die sale agreement with NXP Semiconductors through its legal department.

21.4 Trademarks

Notice: All referenced brands, product names, service names and trademarks are the property of their respective owners.

I²C-bus — logo is a trademark of NXP B.V.

22. Contact information

For more information, please visit: <http://www.nxp.com>

For sales office addresses, please send an email to: salesaddresses@nxp.com

23. Contents

1	General description	1	13.1	Cascaded operation	31
2	Features and benefits	1	14	Bare die description	34
3	Ordering information	2	14.1	Gold bump hardness	34
4	Marking	2	14.2	Alignment marks	34
5	Block diagram	2	14.3	Bump locations	34
6	Pinning information	3	15	Bare die outline	38
6.1	Pinning	3	16	Handling information	39
6.2	Pin description	3	17	Packing information	39
7	Functional description	4	18	Abbreviations	40
7.1	Power-on reset	4	19	References	41
7.2	LCD bias generator	5	20	Revision history	42
7.3	LCD voltage selector	5	21	Legal information	43
7.4	LCD drive mode waveforms	7	21.1	Data sheet status	43
7.4.1	Static drive mode	7	21.2	Definitions	43
7.4.2	1:2 multiplex drive mode	8	21.3	Disclaimers	43
7.4.3	1:3 multiplex drive mode	10	21.4	Trademarks	44
7.4.4	1:4 multiplex drive mode	11	22	Contact information	44
7.5	Oscillator	12	23	Contents	45
7.5.1	Internal clock	12			
7.5.2	External clock	12			
7.6	Timing	12			
7.7	Display register	12			
7.8	Segment outputs	12			
7.9	Backplane outputs	13			
7.10	Display RAM	13			
7.11	Data pointer	15			
7.12	Subaddress counter	15			
7.13	Output bank selector	16			
7.14	Input bank selector	16			
7.15	Blinker	16			
8	I²C-bus interface	18			
8.1	Characteristics of the I ² C-bus	18			
8.1.1	Bit transfer	18			
8.1.1.1	START and STOP conditions	18			
8.1.2	System configuration	19			
8.1.3	Acknowledge	19			
8.1.4	I ² C-bus controller	20			
8.1.5	Input filters	20			
8.1.6	I ² C-bus protocol	20			
8.2	Command decoder	22			
8.3	Display controller	23			
9	Internal circuitry	24			
10	Limiting values	25			
11	Static characteristics	26			
12	Dynamic characteristics	28			
13	Application information	31			

Please be aware that important notices concerning this document and the product(s) described herein, have been included in section 'Legal information'.

© NXP B.V. 2010.

All rights reserved.

For more information, please visit: <http://www.nxp.com>

For sales office addresses, please send an email to: salesaddresses@nxp.com

Date of release: 5 March 2010

Document identifier: PCF8533_4