

PLEASE CHECK WWW.MOLEX.COM FOR LATEST PART INFORMATION

Part Number: [0016020116](#)
Status: **Active**
Overview: [cgrid_sl_products](#)
Description: SL™ Crimp Terminal, Series 70021, Male, with 0.76µm (30µ") Selective Gold (Au) Plated Contact, 22-24 AWG, Reel

Documents:

[Drawing \(PDF\)](#) [RoHS Certificate of Compliance \(PDF\)](#)
[Product Specification PS-70021 \(PDF\)](#)

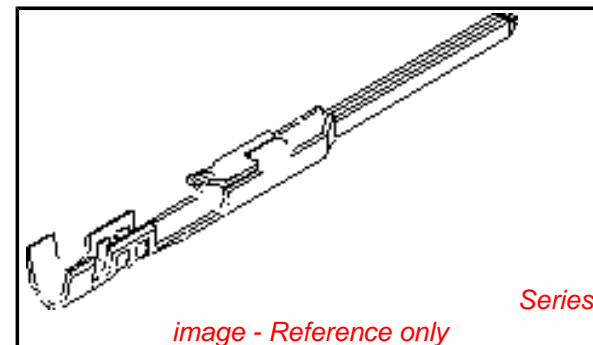

General

Product Family	Crimp Terminals
Series	70021
Crimp Quality Equipment	Yes
Overview	cgrid_sl_products
Product Name	SL™

Physical

Gender	Male
Material - Metal	Phosphor Bronze
Material - Plating Mating	Gold
Material - Plating Termination	Tin
Packaging Type	Reel
Plating min: Mating (µin)	30
Plating min: Mating (µm)	0.75
Plating min: Termination (µin)	75
Plating min: Termination (µm)	1.875
Termination Interface: Style	Crimp or Compression
Wire Insulation Diameter	1.63mm (.064") max.
Wire Size AWG	22, 24
Wire Size mm²	N/A

Material Info

Old Part Number 70021-0025

Reference - Drawing Numbers

Packaging Specification	PK-70873-1300
Product Specification	PS-70021
Sales Drawing	SD-70021-0025

<p>EU RoHS ELV and RoHS Compliant REACH SVHC Contains SVHC: No Halogen-Free Status Halogen-Free</p>	<p>China RoHS</p> 
--	--

Need more information on product environmental compliance?

Email productcompliance@molex.com
 For a multiple part number RoHS Certificate of Compliance, [click here](#)

Please visit the [Contact Us](#) section for any non-product compliance questions.

Search Parts in this Series
[70021Series](#)

Use With
[70066 Housing](#), [70107 Housing](#)

Application Tooling | FAQ
Tooling specifications and manuals are found by selecting the products below. Crimp Height Specifications are then contained in the Application Tooling Specification document.

Global Description	Product #
FineAdjust™ Applicator for SL™ Crimp Terminal, Male, 22 AWG	0639014600
FineAdjust™ Applicator T2 Terminator Tooling Die	0639003500
Hand Crimp Tool	0639103500
Insertion Tool	0638118700
Extraction Tool	0011020022
	0011030036

Japan

Description

Product #

Applicator for M211A 0570173000

Bench Press, 22-30

AWG, for 70021

Crimp Terminal

Hand Insertion Tool 0570336000

This document was generated on 05/18/2010

PLEASE CHECK WWW.MOLEX.COM FOR LATEST PART INFORMATION

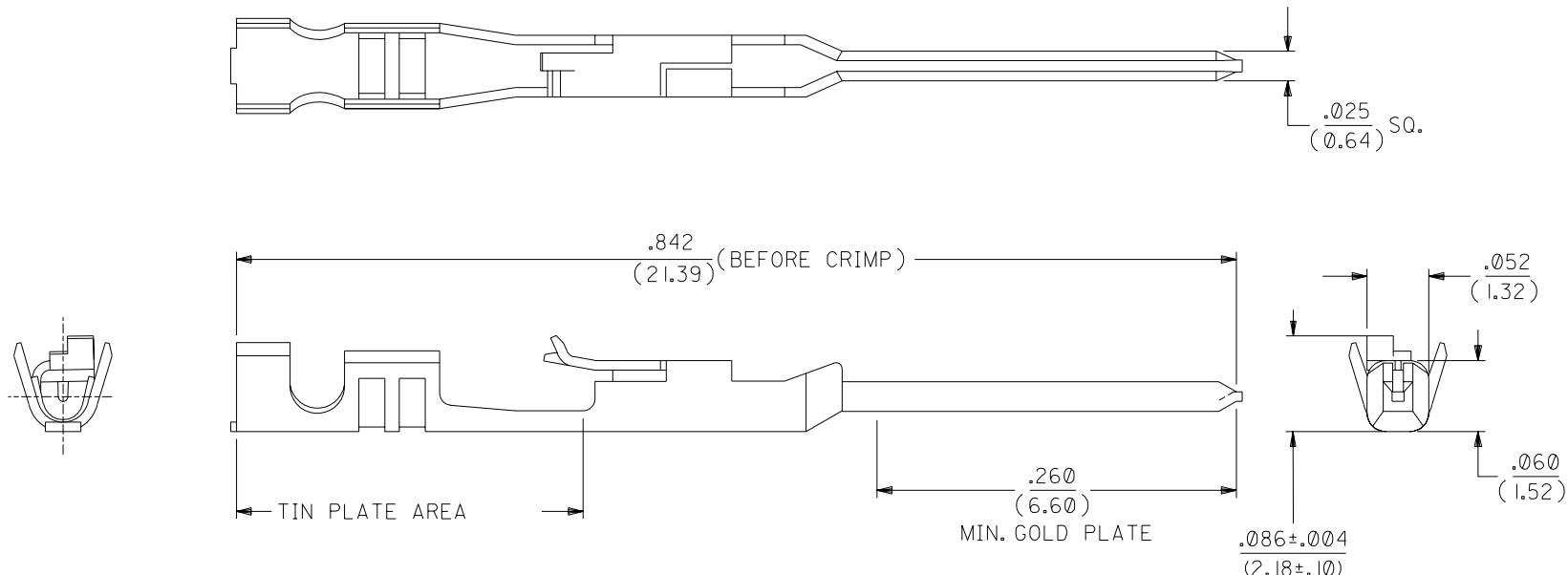

NOTES:

1. TERMINAL FOR USE WITH HOUSING PART NO. 70066-**** & 70107-****.
2. MATERIAL: .008/(0.20) THK. PHOSPHOR BRONZE.
3. TERMINAL TO BE USED WITH 22-24 AWG STRANDED WIRE WITH .064 DIA. MAX. INSULATION.
4. REFER TO MOLEX OPERATIONAL AND SERVICE MANUAL FOR DETAILS.
5. REFER TO PRODUCT SPECIFICATION NO. PS-70021.
6. PARTS SUPPLIED IN REEL FORM.

PLATING:

.000030 GOLD PLATE IN SELECT AREA.
 .000075 MIN. TIN PLATE IN SELECT AREA.
 OVER NICKEL PLATE.

*THE PRIMARY SHIPPING CARTON WILL BE LABELED "COMPLIANT TO RoHS DIRECTIVE 2002/95/EC AND ELV ANNEX II OF DIRECTIVE 2000/53/EC". CARTONS WITHOUT THIS LABEL MAY CONTAIN PRODUCT WITH LEAD.

E	LEAD FREE UCP2004-1769 RWHITE 04/03/12
D1	REVISED ECR #U80270 MCGRATH 97/07/31
D	REVISED PLTG. SPEC. PER ECR # U31149 08/19/93 REED
C	REVISED PER ECR# U82220 11-07-88 MJM/MGB
B	REDRAWN ON CAD PER E.C.R. #9509 11/10/86 WJF/MJM

MFG. SH.	REV.	LTR.	REVISIONS
----------	------	------	-----------

DIMENSIONS SHOWN (METRIC): INCH		▽ = 0		▼ = 0		REVISE ONLY ON CAD SYSTEM	
UNLESS OTHERWISE SPECIFIED TOLERANCES: ANGULAR ± 1/2°							
		INCH		METRIC			
3 PLACE	± .010	---					
2 PLACE	± .015	± 0.25					
1 PLACE	---	± 0.35					
DRAFT WHERE APPLICABLE MUST REMAIN WITHIN DIMENSIONS							
DRWG. BY: WJF		CHK'D. BY: MJM		FILE NAME: S70021X25 DGN		THIS DRAWING CONTAINS INFORMATION THAT IS PROPRIETARY TO MOLEX INC. AND SHOULD NOT BE USED WITHOUT WRITTEN PERMISSION.	
APP'D. BY: WAZ		SCALE: 10: 1		PART NO. 16-02-0116		DRWG. NO. SD-70021-0025	
				MOLEX INCORPORATED LITTLE ROCK, AR 60532 U.S.A.		SHEET NO. 1 DATE 10/30/86	
				DA		B	

TERMINAL, MALE CRIMP

MOLEX INCORPORATED LITTLE ROCK, AR 60532 U.S.A. SHEET NO. 1 DATE 10/30/86

PART NO. 16-02-0116 DRWG. NO. SD-70021-0025

DA B