

1A LDO VOLTAGE REGULATOR

DESCRIPTION

The SA1117 is a positive low voltage dropout regulator, voltage dropout is only 1.2V at 1A.

SA1117 has two versions: the fixed version and the adjustable version. VOUT has a tolerance of less than 1% for fixed versions 1.5V, 1.8V, 2.5V, 3.3V, 5.0V and adjustable version or 2% output accuracy for fixed version 1.2V.

The SA1117 integrates overheating protection and current limit circuits. It is an suitable for all electronic products.

FEATURES

- * 1% accuracy for fixed output VOUT while the voltage is 1.5V, 1.8V, 2.5V, 3.3V, 5.0V and the adjustable output VOUT
- * 2% output accuracy for fixed version 1.2V
- * Low Dropout Voltage: 1.2V at 1A output current
- * Current Limiting
- * Thermal Shutdown
- * Temperature Range: -40°C to 125°C

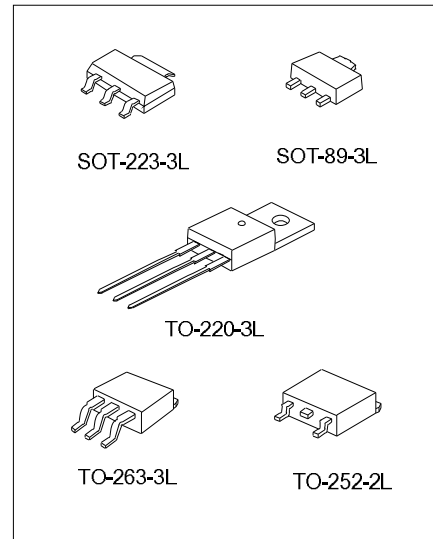

APPLICATIONS

- * Laptop, Palmtop, and Notebook Computers
- * Battery Charger
- * SCSI-|| Active Terminator
- * Cellular Phone
- * Cordless Telephones
- * Battery Powered Systems
- * Portable Devices
- * SMPS Post-Regulator

ORDERING INFORMATION (Temperature range: -40°C ~125°C)

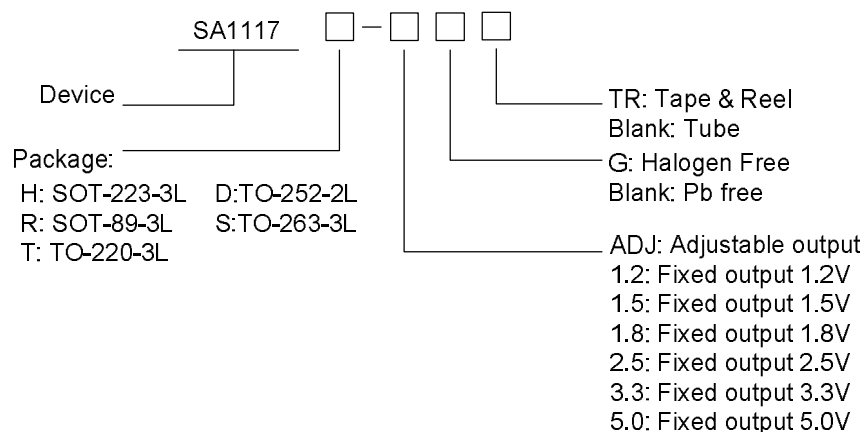

Part No.	Package	Marking	Material	Packing Type
SA1117H-ADJTR	SOT-223-3L	SA1117H-ADJ	Pb free	Tape & Reel
SA1117H-1.2TR		SA1117H-1.2	Pb free	Tape & Reel
SA1117H-1.5TR		SA1117H-1.5	Pb free	Tape & Reel
SA1117H-1.8TR		SA1117H-1.8	Pb free	Tape & Reel
SA1117H-2.5TR		SA1117H-2.5	Pb free	Tape & Reel
SA1117H-3.3TR		SA1117H-3.3	Pb free	Tape & Reel
SA1117H-5.0TR		SA1117H-5.0	Pb free	Tape & Reel
SA1117R-ADJ TR	SOT-89-3L	SAJR	Pb free	Tape & Reel
SA1117R-1.2TR		S12R	Pb free	Tape & Reel
SA1117R-1.5TR		S15R	Pb free	Tape & Reel
SA1117R-1.8TR		S18R	Pb free	Tape & Reel
SA1117R-2.5TR		S25R	Pb free	Tape & Reel
SA1117R-3.3TR		S33R	Pb free	Tape & Reel
SA1117R-5.0TR		S50R	Pb free	Tape & Reel
SA1117T-ADJ	TO-220-3L	SA1117T-ADJ	Pb free	Tube
SA1117T-1.2		SA1117T-1.2	Pb free	Tube
SA1117T-1.5		SA1117T-1.5	Pb free	Tube
SA1117T-1.8		SA1117T-1.8	Pb free	Tube
SA1117T-2.5		SA1117T-2.5	Pb free	Tube
SA1117T-3.3		SA1117T-3.3	Pb free	Tube
SA1117T-5.0		SA1117T-5.0	Pb free	Tube
SA1117D-ADJ	TO-252-2L	SA1117D-ADJ	Pb free	Tube
SA1117D-ADJTR		SA1117D-ADJ	Pb free	Tape & Reel
SA1117D-1.2		SA1117D-1.2	Pb free	Tube
SA1117D-1.2TR		SA1117D-1.2	Pb free	Tape & Reel
SA1117D-1.5		SA1117D-1.5	Pb free	Tube
SA1117D-1.5TR		SA1117D-1.5	Pb free	Tape & Reel
SA1117D-1.8		SA1117D-1.8	Pb free	Tube
SA1117D-1.8TR		SA1117D-1.8	Pb free	Tape & Reel
SA1117D-2.5		SA1117D-2.5	Pb free	Tube
SA1117D-2.5TR		SA1117D-2.5	Pb free	Tape & Reel
SA1117D-3.3		SA1117D-3.3	Pb free	Tube
SA1117D-3.3TR		SA1117D-3.3	Pb free	Tape & Reel
SA1117D-5.0		SA1117D-5.0	Pb free	Tube
SA1117D-5.0TR		SA1117D-5.0	Pb free	Tape & Reel
SA1117S-ADJ	TO-263-3L	SA1117S-ADJ	Pb free	Tube
SA1117S-ADJTR		SA1117S-ADJ	Pb free	Tape & Reel
SA1117S-1.2		SA1117S-1.2	Pb free	Tube
SA1117S-1.2TR		SA1117S-1.2	Pb free	Tape & Reel
SA1117S-1.5		SA1117S-1.5	Pb free	Tube
SA1117S-1.5TR		SA1117S-1.5	Pb free	Tape & Reel

Part No.	Package	Marking	Material	Packing Type
SA1117S-1.8	TO-263-3L	SA1117S-1.8	Pb free	Tube
SA1117S-1.8TR		SA1117S-1.8	Pb free	Tape & Reel
SA1117S-2.5		SA1117S-2.5	Pb free	Tube
SA1117S-2.5TR		SA1117S-2.5	Pb free	Tape & Reel
SA1117S-3.3		SA1117S-3.3	Pb free	Tube
SA1117S-3.3TR		SA1117S-3.3	Pb free	Tape & Reel
SA1117S-5.0		SA1117S-5.0	Pb free	Tube
SA1117S-5.0TR		SA1117S-5.0	Pb free	Tape & Reel
SA1117H-ADJGTR	SOT-223-3L	1117H-ADJG	Halogen free	Tape & Reel
SA1117H-1.2GTR		1117H-1.2G	Halogen free	Tape & Reel
SA1117H-1.5GTR		1117H-1.5G	Halogen free	Tape & Reel
SA1117H-1.8GTR		1117H-1.8G	Halogen free	Tape & Reel
SA1117H-2.5GTR		1117H-2.5G	Halogen free	Tape & Reel
SA1117H-3.3GTR		1117H-3.3G	Halogen free	Tape & Reel
SA1117H-5.0GTR		1117H-5.0G	Halogen free	Tape & Reel
SA1117R-ADJGTR	SOT-89-3L	RAJG	Halogen free	Tape & Reel
SA1117R-1.2GTR		R12G	Halogen free	Tape & Reel
SA1117R-1.5GTR		R15G	Halogen free	Tape & Reel
SA1117R-1.8GTR		R18G	Halogen free	Tape & Reel
SA1117R-2.5GTR		R25G	Halogen free	Tape & Reel
SA1117R-3.3GTR		R33G	Halogen free	Tape & Reel
SA1117R-5.0GTR		R50G	Halogen free	Tape & Reel
SA1117T-ADJG	TO-220-3L	1117T-ADJG	Halogen free	Tube
SA1117T-1.2G		1117T-1.2G	Halogen free	Tube
SA1117T-1.5G		1117T-1.5G	Halogen free	Tube
SA1117T-1.8G		1117T-1.8G	Halogen free	Tube
SA1117T-2.5G		1117T-2.5G	Halogen free	Tube
SA1117T-3.3G		1117T-3.3G	Halogen free	Tube
SA1117T-5.0G		1117T-5.0G	Halogen free	Tube
SA1117D-ADJG	TO-252-2L	1117D-ADJG	Halogen free	Tube
SA1117D-ADJGTR		1117D-ADJG	Halogen free	Tape & Reel
SA1117D-1.2G		1117D-1.2G	Halogen free	Tube
SA1117D-1.2GTR		1117D-1.2G	Halogen free	Tape & Reel
SA1117D-1.5G		1117D-1.5G	Halogen free	Tube
SA1117D-1.5GTR		1117D-1.5G	Halogen free	Tape & Reel
SA1117D-1.8G		1117D-1.8G	Halogen free	Tube
SA1117D-1.8GTR		1117D-1.8G	Halogen free	Tape & Reel
SA1117D-2.5G		1117D-2.5G	Halogen free	Tube
SA1117D-2.5GTR		1117D-2.5G	Halogen free	Tape & Reel

Part No.	Package	Marking	Material	Packing Type
SA1117D-3.3G	TO-252-2L	1117D-3.3G	Halogen free	Tube
SA1117D-3.3GTR		1117D-3.3G	Halogen free	Tape & Reel
SA1117D-5.0G		1117D-5.0G	Halogen free	Tube
SA1117D-5.0GTR		1117D-5.0G	Halogen free	Tape & Reel
SA1117S-ADJG	TO-263-3L	1117S-ADJG	Halogen free	Tube
SA1117S-ADJGTR		1117S-ADJG	Halogen free	Tape & Reel
SA1117S-1.2G		1117S-1.2G	Halogen free	Tube
SA1117S-1.2GTR		1117S-1.2G	Halogen free	Tape & Reel
SA1117S-1.5G		1117S-1.5G	Halogen free	Tube
SA1117S-1.5GTR		1117S-1.5G	Halogen free	Tape & Reel
SA1117S-1.8G		1117S-1.8G	Halogen free	Tube
SA1117S-1.8GTR		1117S-1.8G	Halogen free	Tape & Reel
SA1117S-2.5G		1117S-2.5G	Halogen free	Tube
SA1117S-2.5GTR		1117S-2.5G	Halogen free	Tape & Reel
SA1117S-3.3G		1117S-3.3G	Halogen free	Tube
SA1117S-3.3GTR		1117S-3.3G	Halogen free	Tape & Reel
SA1117S-5.0G		1117S-5.0G	Halogen free	Tube
SA1117S-5.0GTR		1117S-5.0G	Halogen free	Tape & Reel

BLOCK DIAGRAM

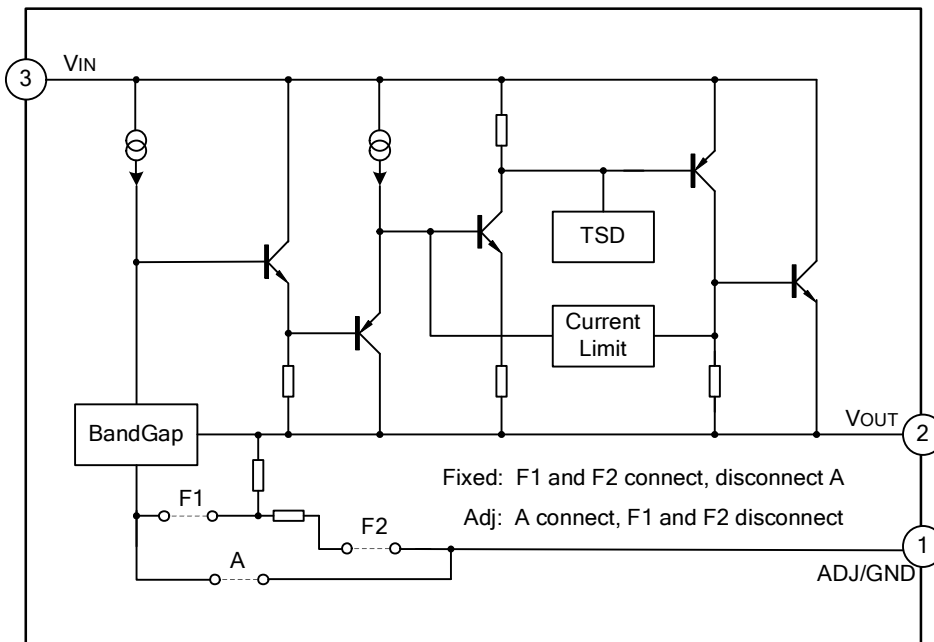

ABOSOLUTE MAXIMUM RATINGS

Characteristics	Symbol	Ratings	Unit
Input Supply Voltage	V _{IN}	20	V
Lead Temperature (Soldering, 5 seconds)	T _{Lead}	260	°C
Operating Junction Temperature Range	T _J	150	°C
Storage Temperature Range	T _{STG}	-65 ~ +150	°C
Power Dissipation	P _D	Internally Limited (Note1)	mW
ESD Tolerance (Minimum)	ESD	2000	V

Note1: The maximum allowable power dissipation is a function of maximum operating junction temperature T_J (max), the junction to ambient thermal resistance θ_{JA}, and the ambient temperature T_{amb}. The maximum allowable power dissipation at any ambient temperature is given: P_D (max) = (T_J (max) - T_{amb})/θ_{JA}, exceeding the maximum allowable power limit will result in excessive die temperature; thus, the regulator will go into thermal shutdown. The junction to ambient thermal resistance θ_{JA} of different packages may be different, and the he value of θ_{JA} depends on mounting technique.

RECOMMENDED OPERATING CONDITIONS

Characteristics	Symbol	Ratings	Unit
Input Voltage	V _{IN}	15	V
Operating Junction Temperature Range	T _J	-40 ~ +125	°C

ELECTRICAL CHARACTERISTICS (T_{amb}=25°C, unless otherwise specified. Limits appearing in Boldface type apply over the entire junction temperature range for operation, -40°C to 125°C.)

Characteristics	Symbol	Conditions	Min.	Typ.	Max.	Unit
Reference Voltage	V _{REF}	SA1117-ADJ, I _{OUT} =10mA, V _{IN} -V _{OUT} =2V, T _J =25°C	1.238	1.250	1.262	V
		10mA ≤ I _{OUT} ≤ 1A, 1.4V ≤ V _{IN} -V _{OUT} ≤ 10V	1.225	1.250	1.270	
Output Voltage	V _{OUT}	SA1117-1.2, I _{OUT} =10mA, V _{IN} =3.2V, T _J =25°C	1.176	1.2	1.224	V
		10mA ≤ I _{OUT} ≤ 1A, 3.0V ≤ V _{IN} ≤ 10V	1.152	1.2	1.248	
		SA1117-1.5, I _{OUT} =10mA, V _{IN} =3.5V, T _J =25°C	1.485	1.500	1.515	V
		10mA ≤ I _{OUT} ≤ 1A, 3.0V ≤ V _{IN} ≤ 10V	1.470	1.500	1.530	
		SA1117-1.8, I _{OUT} =10mA, V _{IN} =3.8V, T _J =25°C ,	1.782	1.800	1.818	V
		0 ≤ I _{OUT} ≤ 1A, 3.2V ≤ V _{IN} ≤ 10V	1.764	1.800	1.836	
Output Voltage	V _{OUT}	SA1117-2.5, I _{OUT} =10mA, V _{IN} =4.5V, T _J =25°C ,	2.475	2.500	2.525	V
		0 ≤ I _{OUT} ≤ 1A, 3.9V ≤ V _{IN} ≤ 10V	2.450	2.500	2.550	
Output Voltage	V _{OUT}	SA1117-3.3, I _{OUT} =10mA, V _{IN} =5V, T _J =25°C ,	3.267	3.300	3.333	V
		0 ≤ I _{OUT} ≤ 1A, 4.75V ≤ V _{IN} ≤ 10V	3.235	3.300	3.365	

Characteristics	Symbol	Conditions	Min.	Typ.	Max.	Unit
Output Voltage	V _{OUT}	SA1117-5.0, I _{OUT} =10mA, V _{IN} =7V, T _J =25°C, 0 ≤ I _{OUT} ≤ 1A, 6.5V ≤ V _{IN} ≤ 12V	4.950 4.900	5.000 5.000	5.05 5.10	V
Output Voltage Temperature Stability	T _{SOUT}			0.3		%
Line Regulation	R _{line}	V _{INMIN} ≤ V _{IN} ≤ 12V, V _{OUT} =Fixed/Adj, I _{OUT} =10mA		3	7	mV
Load Regulation	R _{load}	10mA ≤ I _{OUT} ≤ 1A, V _{OUT} =Fixed/Adj		6	12	mV
Dropout Voltage	V _{drop}	I _{OUT} =100mA I _{OUT} =500mA I _{OUT} =1A		1.00 1.05 1.10	1.20 1.25 1.30	V
Quiescent Current	I _q	4.25V ≤ V _{IN} ≤ 6.5V		5	10	mA
Ripple Rejection	PSRR	f _{RIPPLE} =120Hz, (V _{IN} -V _{OUT})=3V, V _{RIPPLE} =1V _{PP}	60	75		dB
Adjust pin Current	I _{adj}			60	120	μA
Adjust pin Current Change		0 ≤ I _{OUT} ≤ 1A, 1.4V ≤ V _{IN} -V _{OUT} ≤ 10V		0.2	5	μA
Thermal shutdown	TSD			150		°C
Current limiting	I _{limit}		1.2	1.4	1.5	A
Temperature Stability				0.5		%
Long Term Stability		T _{amb} =125°C, 1000Hrs		0.3		%
RMS Output Noise		% of V _{OUT} , 10Hz ≤ f ≤ 10kHz		0.003		%
Thermal Resistance (No Heat-sink)	θ _{JA}	SOT-223-3L		120		°C/W
		TO-252-2L		100		
		TO-263-3L		60		
		SOT-89-3L		165		
		TO-220-3L		60		

PIN CONFIGURATION

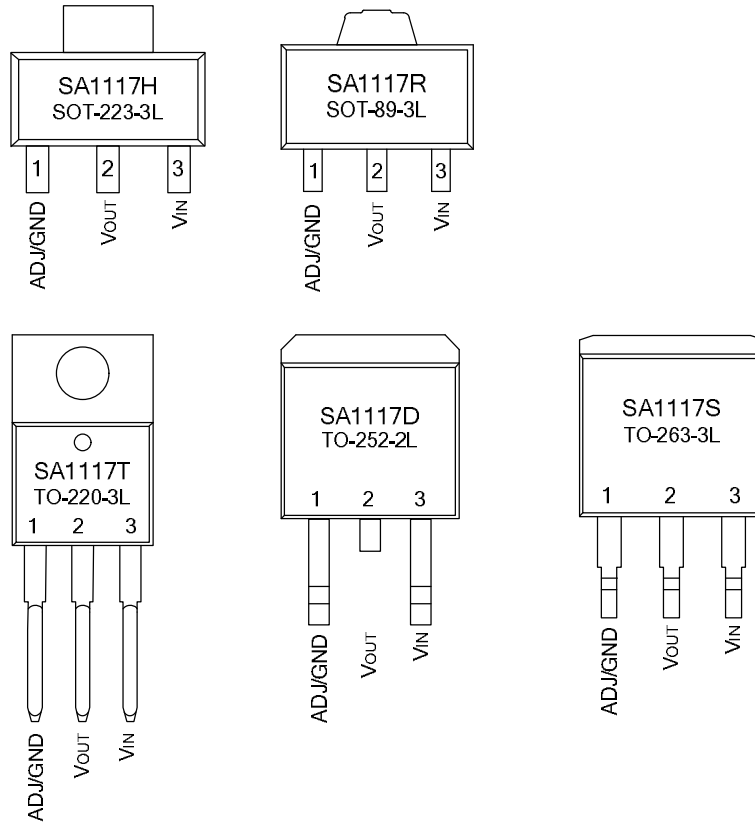

PIN DESCRIPTION

Pin No.	Pin name	I/O	Functions
1	GND/ADJ	--/O	Ground/ADJ
2	V _{OUT}	O	Output voltage
3	V _{IN}	I	Input supply voltage

FUNCTION DESCRIPTION

The SA1117 is a LDO regulator, its pass transistor is made up of a single NPN transistor being driven by a PNP. The dropout voltage is defined as: $V_{DROD} = V_{BE} + V_{SAT}$.

The SA1117 has two versions: the fixed output version and the adjustable output version. Output voltages can be 1.2V, 1.5V, 1.8V, 2.5V, 3.3V, and 5.0V. On-chip thermal shut-down circuit provides protection against overload and overheating that would create excessive junction temperature.

The adjustable output version requires a 22 μF or bigger tantalum capacitor at output for SA1117 stability. The capacitor for fixed output version can be smaller and should be determined base on actual application. Generally, the stability of linear regulator stability decreases with output currents increase.

TYPICAL APPLICATION CIRCUIT

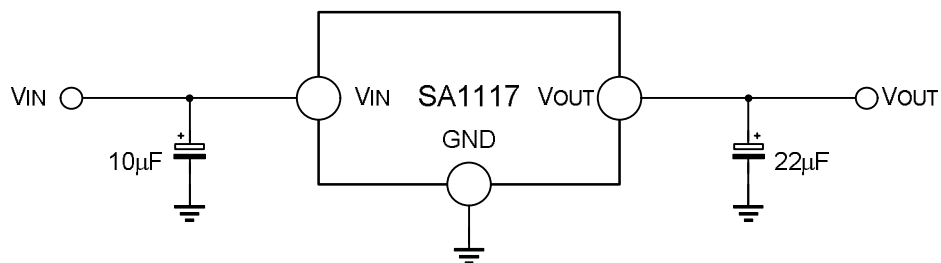

Figure 1. Typical Fixed Output Voltage

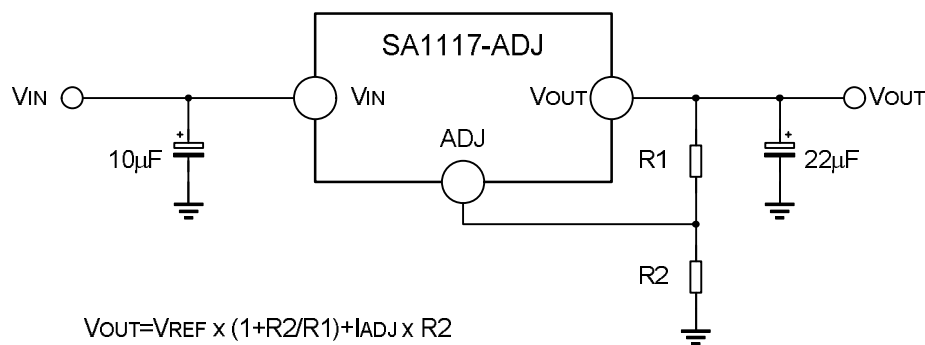
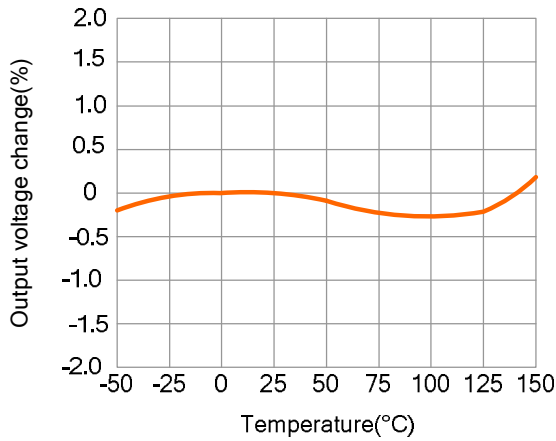

Figure 2. Typical Adjustable Output Voltage

Note: The above circuit and parameters are reference only, please set the parameters of the real application circuit based on the real test.

TYPICAL CHARACTERISTICS CURVES

Temperature Stability



Adjust Pin Current

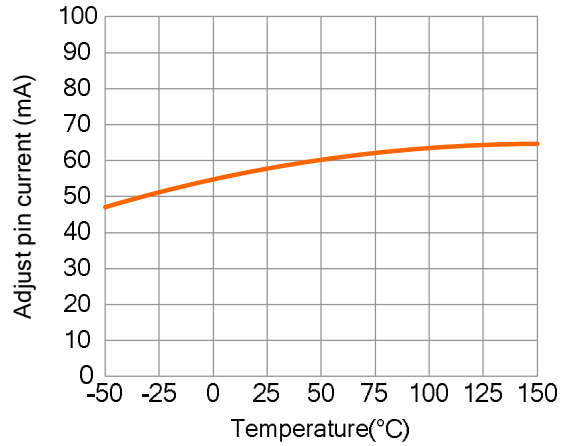

V_{OUT}=5 V Load Transient Response

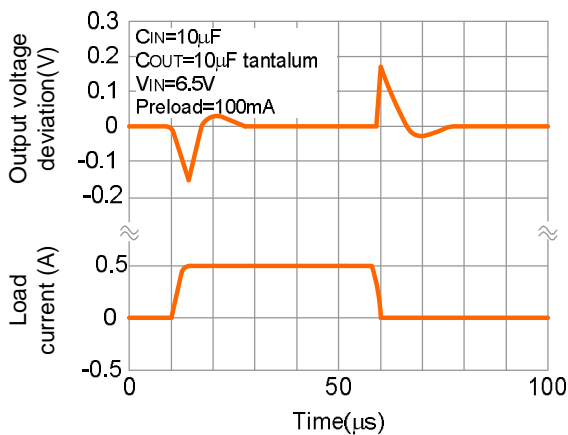

V_{OUT}=5 V Line Transient Response

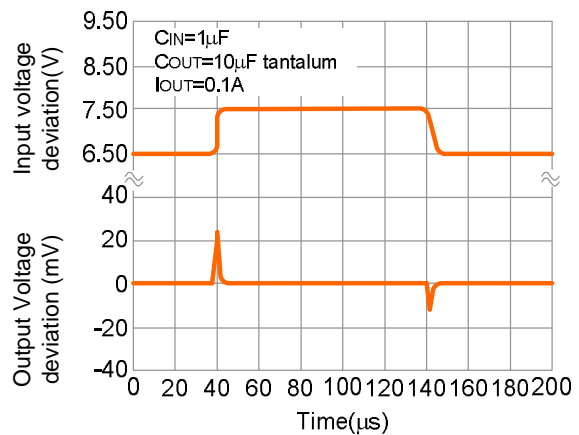

Ripple Rejection VS Current

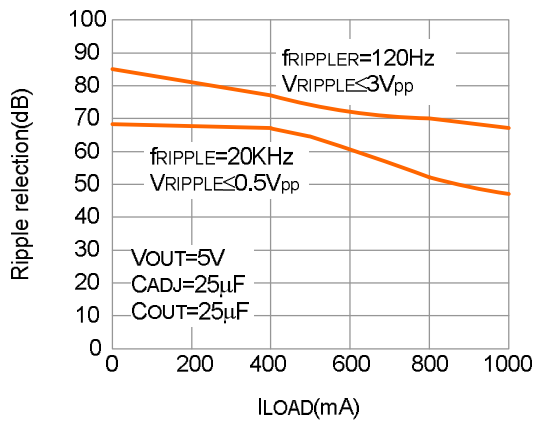

PACKAGE OUTLINE

SOT-223-3L

Unit: mm

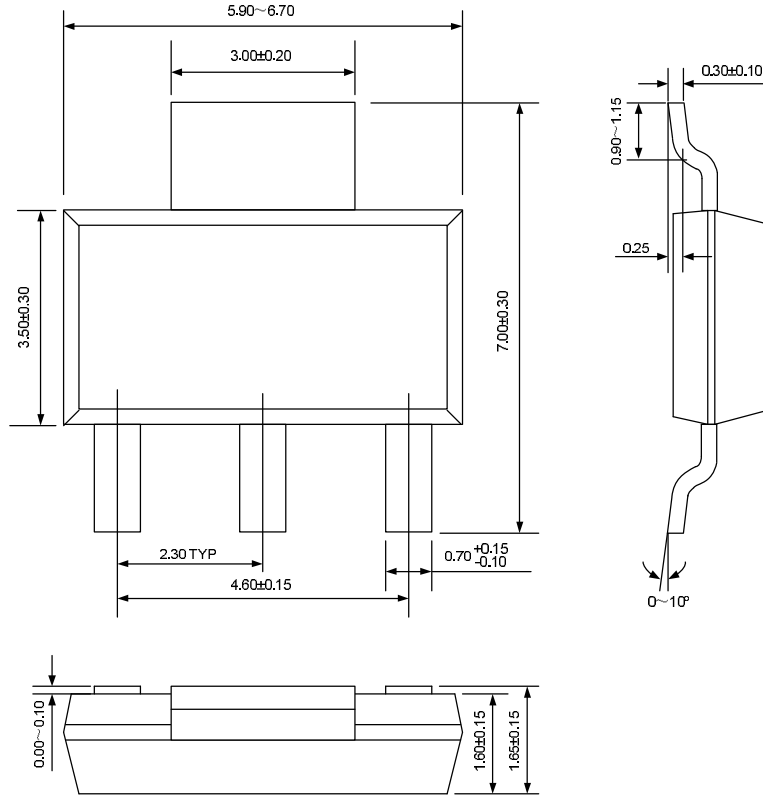

SOT-89-3L

Unit: mm

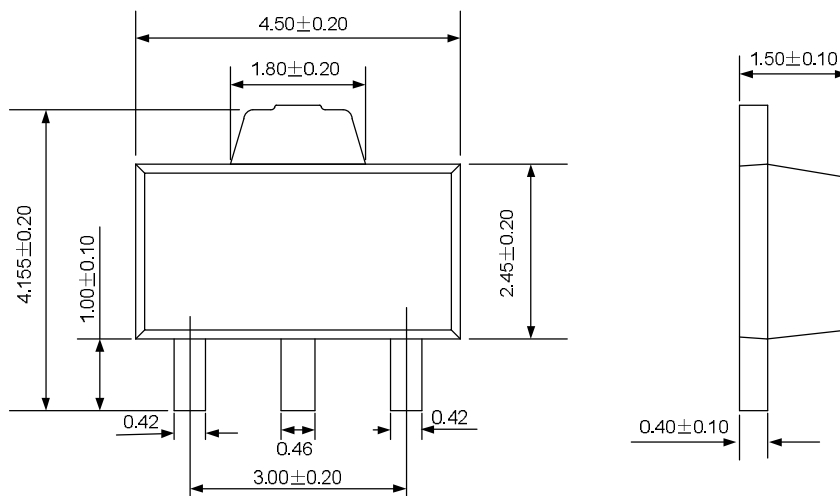

PACKAGE OUTLINE

TO-220-3L

Unit: mm

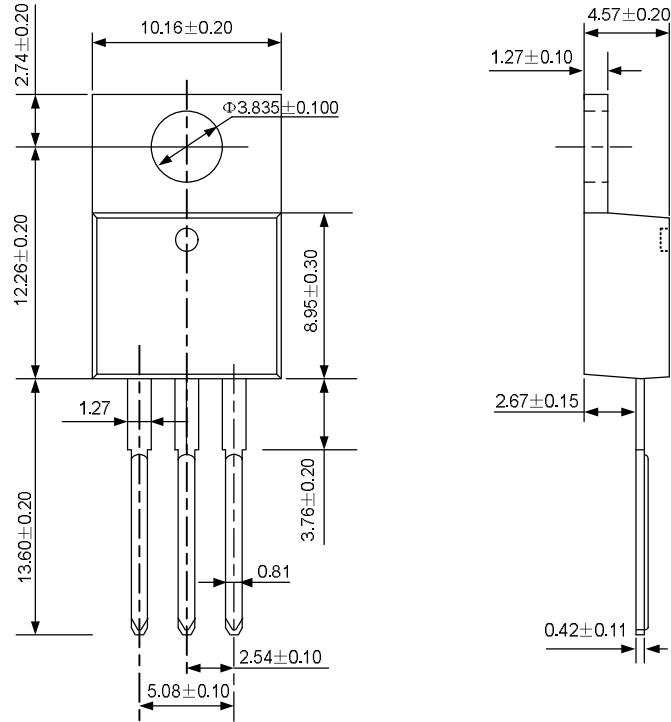

TO-263-3L

Unit: mm

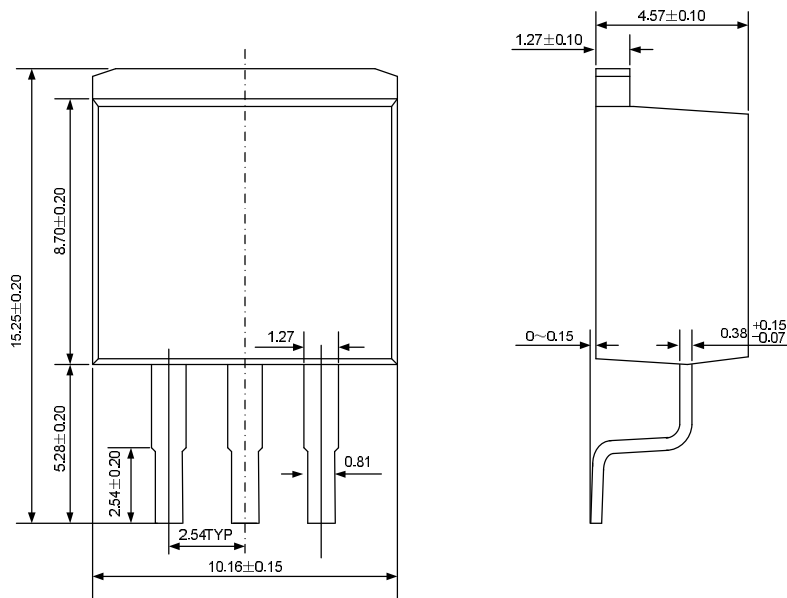

PACKAGE OUTLINE

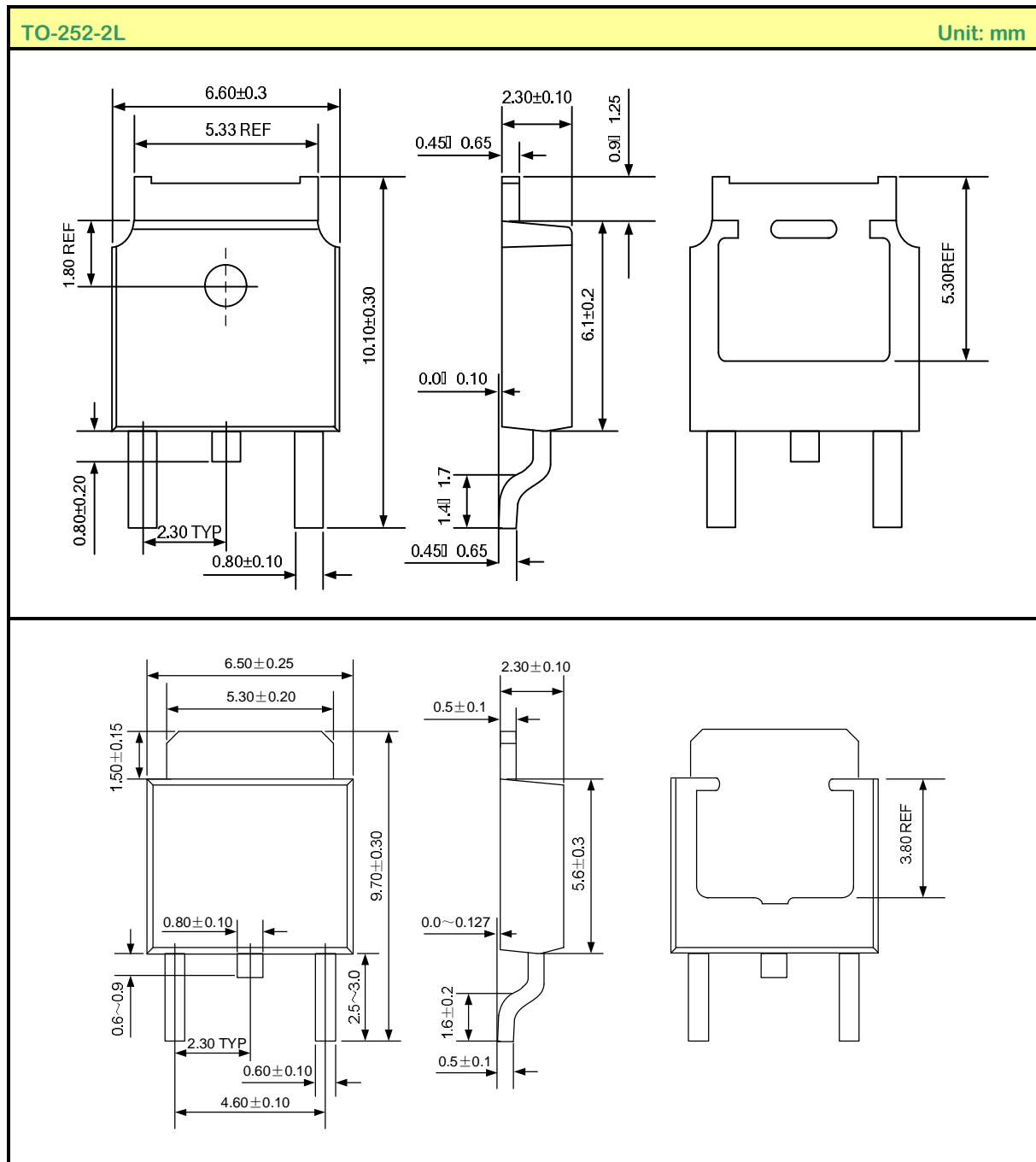

Disclaimer:

- Silan reserves the right to make changes to the information herein for the improvement of the design and performance without further notice!
- All semiconductor products malfunction or fail with some probability under special conditions. When using Silan products in system design or complete machine manufacturing, it is the responsibility of the buyer to comply with the safety standards strictly and take essential measures to avoid situations in which a malfunction or failure of such Silan products could cause loss of body injury or damage to property.
- Silan will supply the best possible product for customers!