

Description

The SE3506 is a step-up DC/DC converter specifically designed to drive white LEDs with a constant current. The device can drive two, three, four, or five LEDs in series from a Li-Ion cell. Series connection of the LEDs provides identical LED current resulting in uniform brightness and eliminating the need for ballast resistors. The SE3506 switches at 1MHz, allowing the use of any tiny external components. The output capacitor can be as small as 1 μ F, saving space and cost versus alternative solutions. A low 95mV feedback voltage minimizes power loss in the current setting resistor for better efficiency.

SE3506 is available in low profile SOT-23-5L package.

Features

- Inherently Matched LED Current.
- High Efficiency: 85% Typical.
- Drives Up to Four LEDs from a 3.0V Supply.
- Drives Up to Six LEDs from a 3.6V Supply.
- Fast 1MHz Switching Frequency.
- Uses Tiny 1mm Tall Inductors.
- Requires Only 1 μ F Output Capacitor.
- Low Profile SOT-23-5L Packaging.
- 100% Lead (Pb)-Free.

Application

- Cellular Phones
- PDAs, Handheld Computers
- Digital Camera
- MP3 Players
- GPS Receivers

Ordering/Marking Information

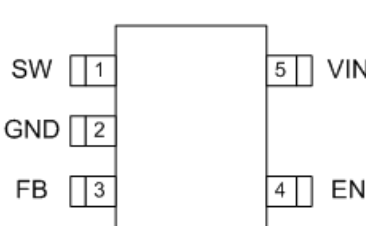
Package	Ordering Information	Marking Information	
SOT-23-5L 	SE3506-LF	506z*	The last character is the batch number.

Application Diagram

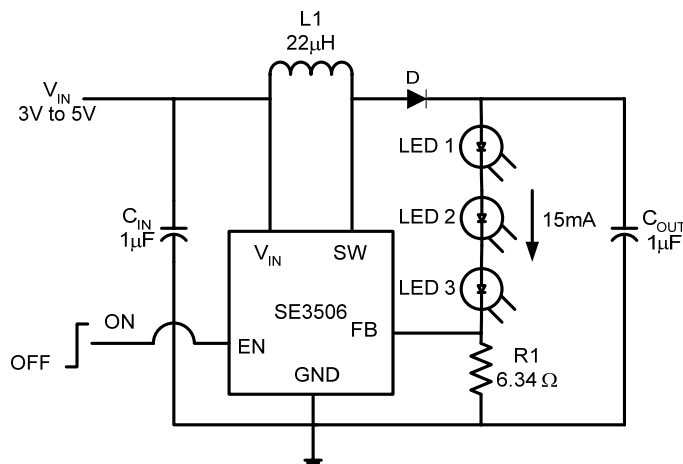



Absolute Maximum Rating ⁽¹⁾

Parameter	Symbol	Value	Units
Input Voltage	V_{IN}	+5.5	V
Switch Voltage	V_{SW}	+30	V
Feedback Voltage	V_{FB}	+5.5	V
Enable Voltage	V_{EN}	+5.5	V
Thermal Resistance, Junction-to-Ambient	Θ_{JA}	250 (SOT-23-5)	°C/W
Lead Temperature (Soldering, 10 sec.)		260	°C
Junction Temperature	T_J	125	°C
Storage Temperature	T_S	-65 to +150	°C

Operating Rating ⁽²⁾

Parameter	Symbol	Value	Units
Supply Input Voltage	V_{IN}	+2.7V to +4.5	V
Junction Temperature	T_J	0 to +125	°C
Extended Commercial Operating Temperature		-40 to +85	°C

Electrical Characteristics

$V_{IN} = V_{EN} = 3.6V$; $C_{IN} = C_{OUT} = 1\mu F$; $T_J = 25^\circ C$; unless otherwise specified

Symbol	Parameter	Conditions	Min	Typ	Max	Unit
V_{IN}	Input Voltage Range		2.7	--	4.5	V
V_{FB}	Feedback Voltage	$I_{SW} = 100mA$, Duty Cycle = 66%	80	95	110	mV
I_{FB}	FB Pin Bias Current		--	45	200	nA
I_{CC}	Supply Current		70	100	160	μA
		$V_{EN} = 0V$	--	0.1	6	μA
	Switching Frequency	$V_{EN} = 4.2V$	0.7	1.0	1.3	MHz
	Maximum Duty Cycle	$V_{EN} = 4.2V$	--	90	--	%
	Switch Leakage Current	$V_{SW} = 5V$		0.1	6	μA
$V_{TH(EN)}$	Enable Input Threshold Voltage	Voltage Raising, Output Turns On, Logic High	1.6	--	--	V
		Voltage Falling, Output Turns Off, Logic Low	--	--	0.4	
I_{EN}	Enable Pin Bias Current		--	45	200-	nA

Note 1: Exceeding the absolute maximum rating may damage the device.

Note 2: The device is not guaranteed to function outside its operating rating. The SE3506 is guaranteed to meet specifications from 0°C to 70°C. Specifications over the -40°C to 85°C operating temperature range are assured by design, characterization and correlation with statistical process controls.

Application Hints

Inductor Selection

A 10 μ H inductor is recommended for most SE3506 applications. Although small size and high efficiency are major concerns, the inductor should have low core losses at 1MHz and low DCR (copper wire resistance). It should also be noted that the Maximum current rating of the inductor should not be exceeded in applications. Typically 100mA to 200mA rating is sufficient for most applications.

Capacitor Selection

The small size of ceramic capacitors makes them ideal for SE3506 applications. X5R and X7R types are recommended because they retain their capacitance over wider voltage and temperature ranges than other types such as Y5V or Z5U. A 1 μ F input capacitor and a 1 μ F output capacitor are sufficient for most SE3506 applications.

Diode Selection

Schottky diodes, with their low forward voltage drop and fast reverse recovery, are the ideal choices for SE3506 applications. The forward voltage drop of a Schottky diode represents the conduction losses in the diode, while the diode capacitance (C_T or C_D) represents the switching losses. For diode selection, both forward voltage drop and diode capacitance need to be considered. Schottky diodes with higher current ratings usually have lower forward voltage drop and larger diode capacitance, which can cause significant switching losses at the 1MHz switching frequency of the SE3506. A Schottky diode rated at 100mA to 200mA is sufficient for most SE3506 applications.

LED Current Control

The LED current is controlled by the feedback resistor (R1). The feedback reference is internally set at 95mV. The LED current is then determined by the equation: $95\text{mV}/R1$. In order to have accurate LED current, precision resistors are preferred (1% is recommended). The formula and table for R1 selection are shown below.

$$R1 = 95\text{mV}/I_{\text{LED}}$$

R1 Resistor Value Selection

I_{LED} (mA)	R1 (Ω)
5	19.1
10	9.53
12	7.87
15	6.34
20	4.75

Open-Circuit Protection

In the cases of output open circuit, such as when the LEDs are disconnected from the circuit or the LEDs fail, the feedback voltage will drop to zero. The SE3506 will then switch at a high duty cycle resulting in a high output voltage, which may cause the SW pin voltage to exceed its maximum 30V rating. A Zener diode can be used at the output to limit the voltage on the SW pin. The Zener voltage should be larger than the maximum forward voltage of the LED string. For example, a Four-LED string can be protected by a Zener diode with a breakdown voltage greater than 16V and less than 30V. The current rating of the zener should be larger than 10mA.

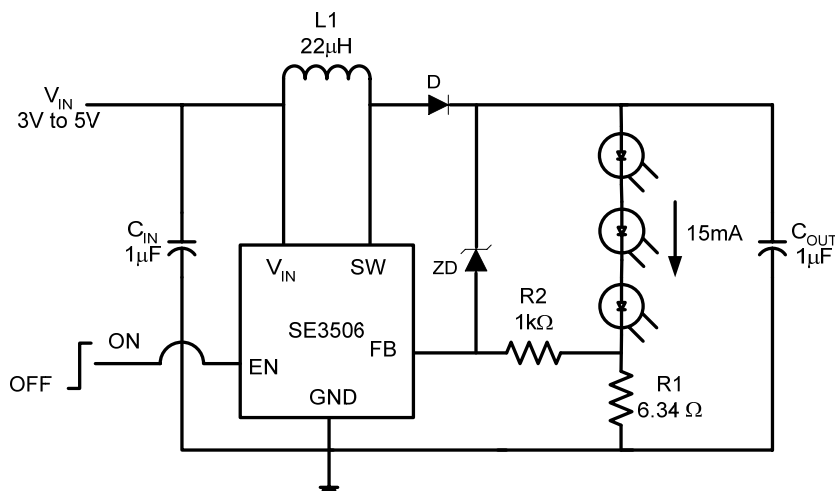

LED Driver with Open-Circuit Protection

Dimming Control

There are two different types of dimming control circuits:

1. Using a PWM Signal to EN Pin

With the PWM signal applied to the EN pin, the SE3506 is turned on or off by the PWM signal. The LEDs operate at either zero or full current. The average LED current increases proportionally with the duty cycle of the PWM signal. A 0% duty cycle will turn off the SE3506 and corresponds to zero LED current. A 100% duty cycle corresponds to full current. The typical frequency range of the PWM signal is 1kHz to 5kHz. The magnitude of the PWM signal should be higher than the minimum EN voltage high. The switching waveforms of the EN pin PWM control are shown below.

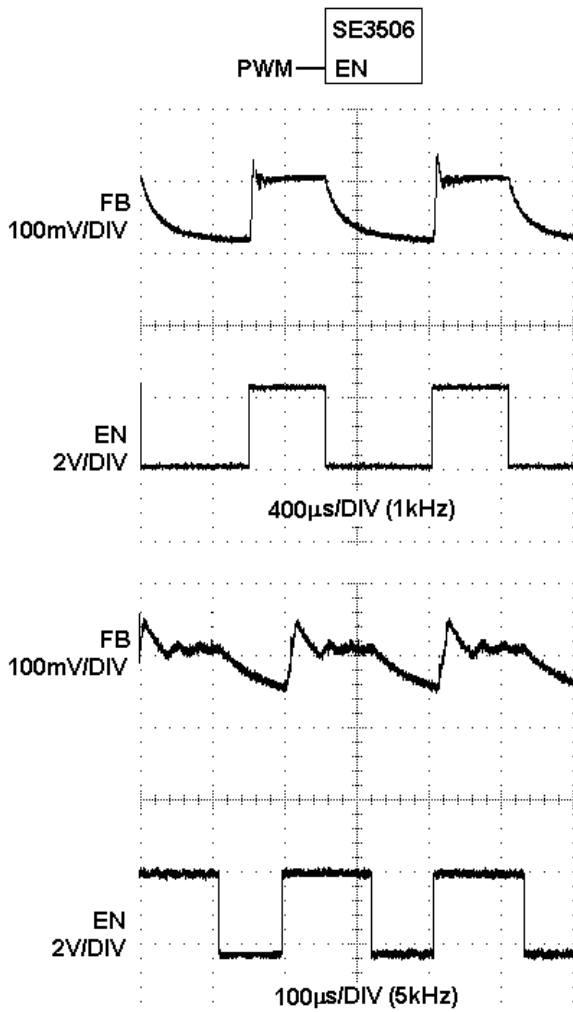

PWM Dimming Control Using the EN Pin

2. Using a DC Voltage

For some applications, the preferred method of brightness control is a variable DC voltage to adjust the LED current. The dimming control using a DC voltage is shown below. As the DC voltage increases, the voltage drop on R2 increases and the voltage drop on R1 decreases. Thus, the LED current decreases. The selection of R2 and R3 will make the current from the variable DC source much smaller than the LED current and much larger than the FB pin bias current. For V_{DC} range from 0V to 2V, the selection of resistors gives dimming control of LED current from 0mA to 15mA.

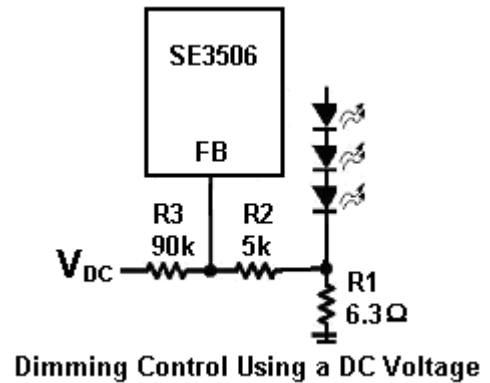



Two LED Efficiency

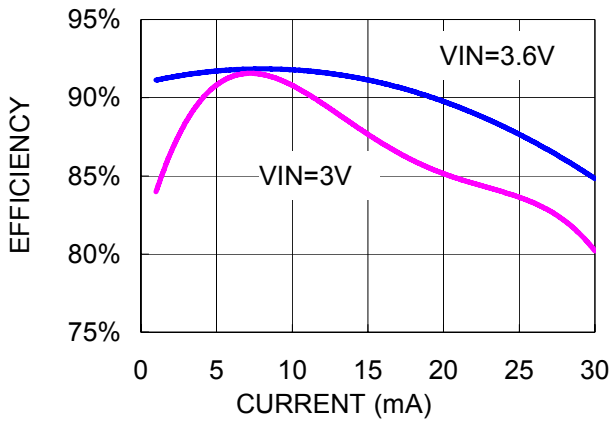

Three LED Efficiency

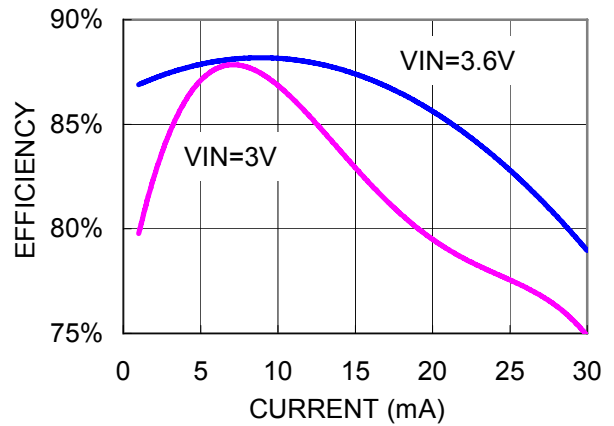

Four LED Efficiency

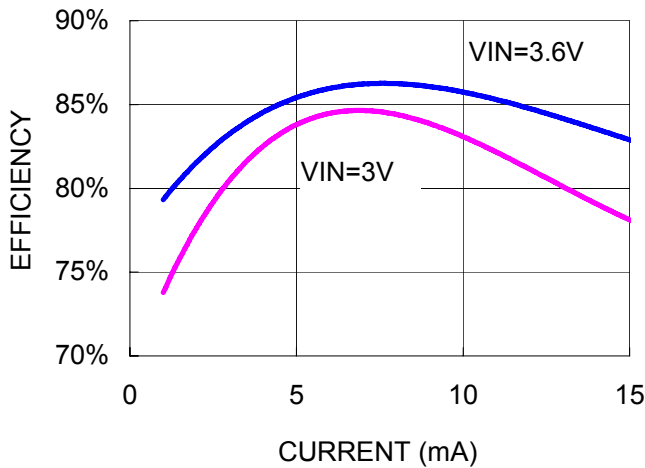

Five LED Efficiency

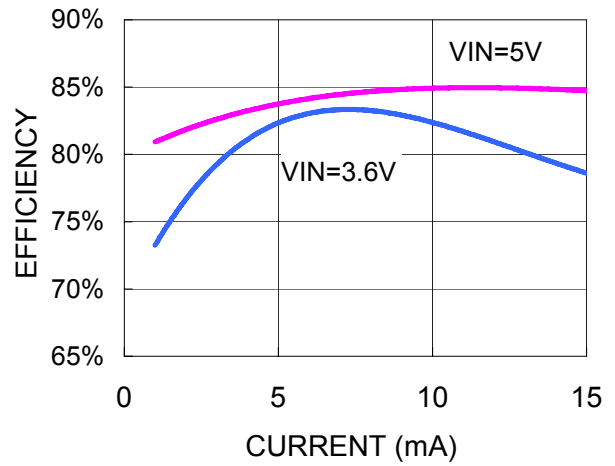

Six LED Efficiency

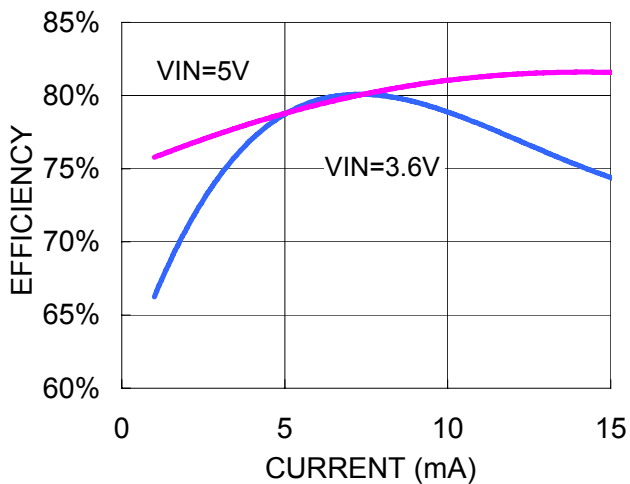

VFB VS. ILOAD

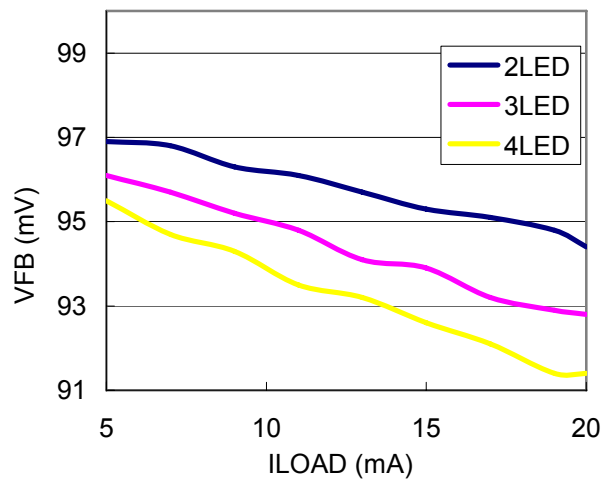



OUTLINE DRAWING SOT-23-5L

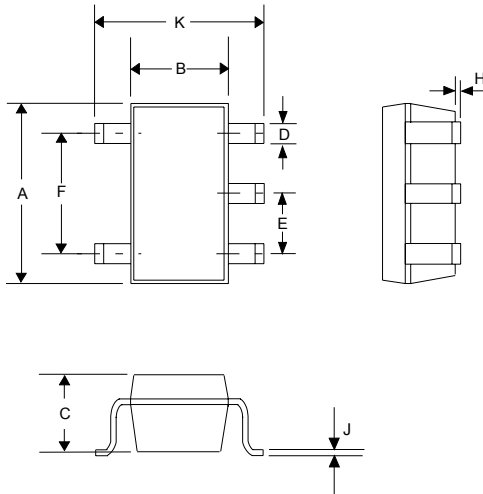

DIMENSIONS				
DIM ^N	INCHES		MM	
	MIN	MAX	MIN	MAX
A	0.110	0.120	2.80	3.05
B	0.059	0.070	1.50	1.75
C	0.036	0.051	0.90	1.30
D	0.014	0.020	0.35	0.50
E	-	0.037	-	0.95
F	-	0.075	-	1.90
H	-	0.006	-	0.15
J	0.0035	0.008	0.090	0.20
K	0.102	0.118	2.60	3.00

Customer Support

Seaward Electronics Incorporated – China

Rm 1605, Building 1, International Pioneering Park, #1 Shangdi Xinxi Rd

Haidian District, Beijing 100085, China

Tel: 86-10-28289-5700

Fax: 86-10-8289-5706

Seaward Electronics Incorporated – Taiwan

2F, #181, Sec. 3, Mincyuan East Rd,

Taipei, Taiwan R.O.C

Tel: 886-2-2712-0307

Fax: 886-2-2712-0191

Seaward Electronics Incorporated – North America

1512 Centre Pointe Dr.

Milpitas, CA95035, USA

Tel: 1-408-821-6600

Last Updated - 12/4/2008