

PLEASE CHECK WWW.MOLEX.COM FOR LATEST PART INFORMATION

Part Number: [0494632217](#)
Status: **Active**
Description: 2.00mm (0.078") LCD Housing Assembly, Single Row, 22 Circuits

Documents:

[Drawing \(PDF\)](#) [RoHS Certificate of Compliance \(PDF\)](#)
[Product Specification PS-49463-001 \(PDF\)](#)

General

Product Family	Other Sockets
Series	49463
Component Type	Socket
Product Name	N/A

Physical

Circuits (Loaded)	22
Color - Resin	Black
Durability (mating cycles max)	200
Entry Angle	Vertical
Keying to Mating Part	None
Material - Metal	Phosphor Bronze
Material - Plating Mating	Tin
Material - Plating Termination	Tin
PCB Locator	Yes
PCB Retention	Yes
Packaging Type	Embossed Tape on Reel
Pitch - Mating Interface (in)	0.078 In
Pitch - Mating Interface (mm)	2.00 mm
Temperature Range - Operating	-30°C to +105°C
Termination Interface: Style	Surface Mount

Electrical

Current - Maximum per Contact	1A
Voltage - Maximum	125V AC (RMS)/DC

Material Info

Reference - Drawing Numbers

Packaging Specification	PK-49463-001
Product Specification	PS-49463-001
Sales Drawing	SD-49463-001, SD-49463-002

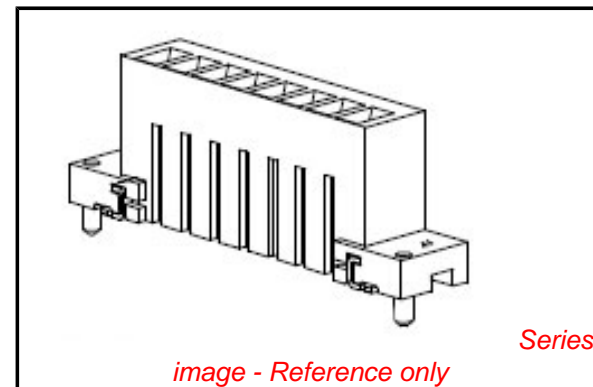

EU RoHS

**ELV and RoHS
Compliant**
**REACH SVHC
Contains SVHC: No**
**Halogen-Free
Status**
Not Reviewed

China RoHS



**Need more information on product
environmental compliance?**

Email productcompliance@molex.com
 For a multiple part number RoHS Certificate of
 Compliance, [click here](#)

Please visit the [Contact Us](#) section for any
 non-product compliance questions.

Search Parts in this Series

[49463Series](#)

Mates With

LCD Module

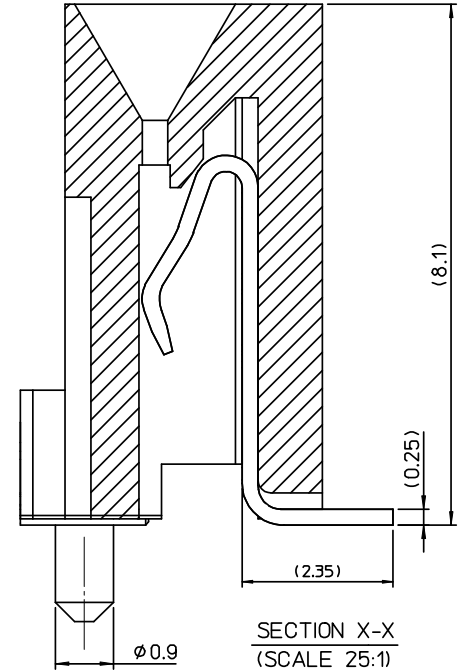
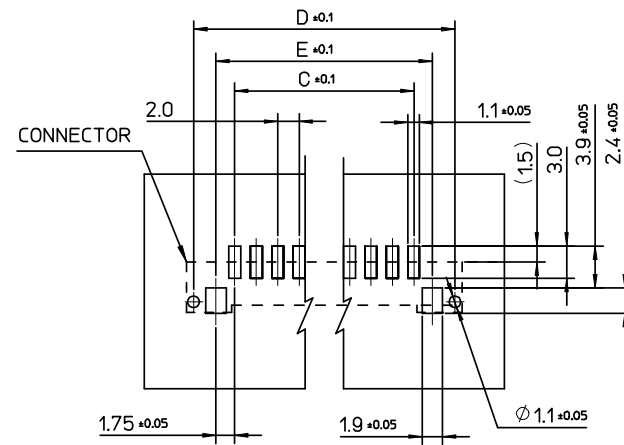
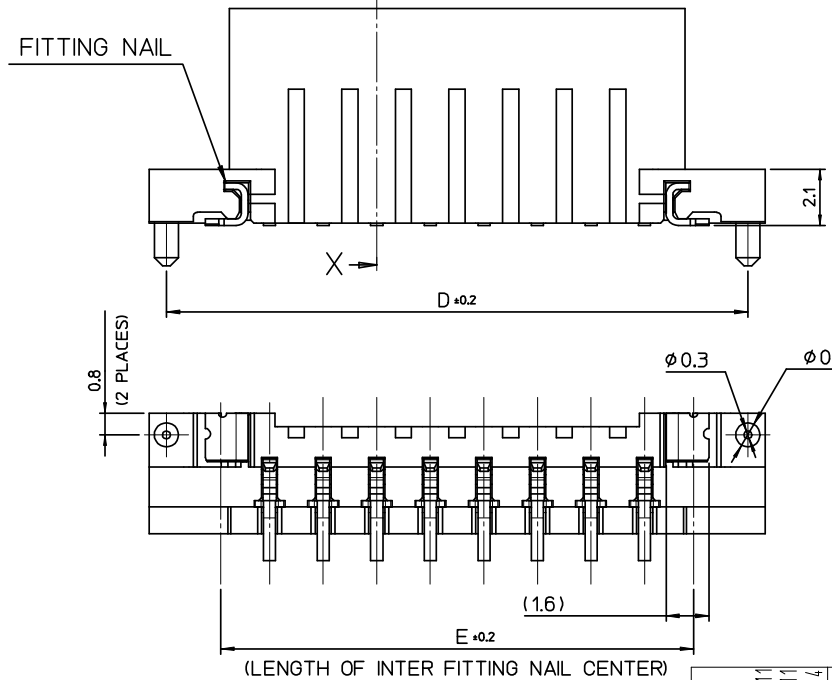
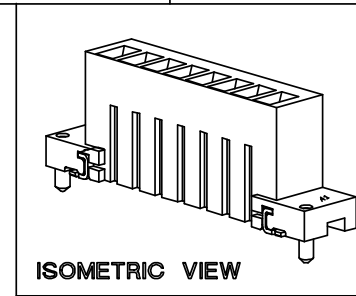
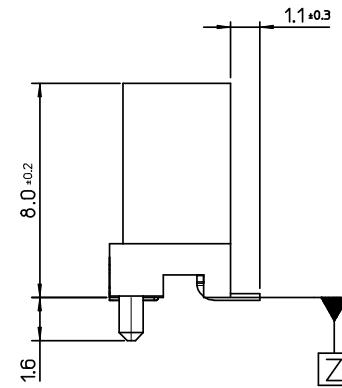
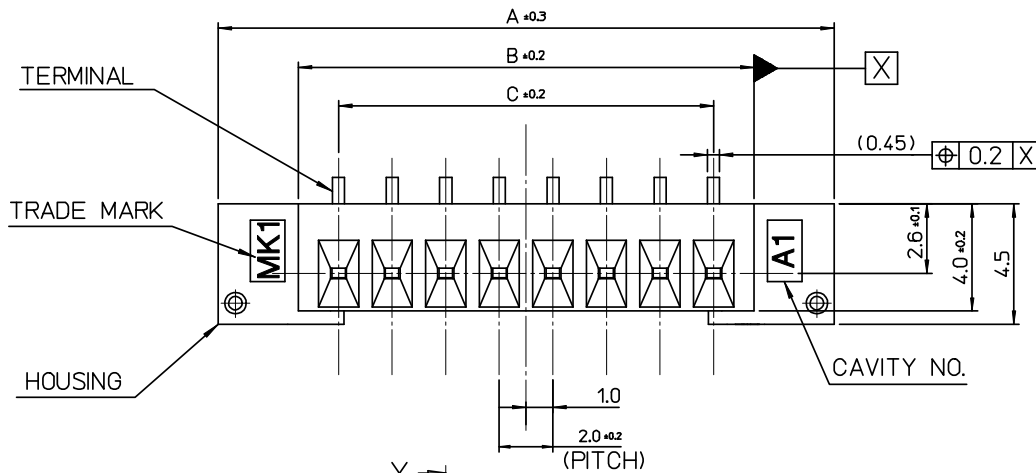

49.65	53.7	46	49	55	494632411	49463-2411	24
45.65	49.7	42	45	51	494632211	49463-2211	22
41.65	45.7	38	41	47	494632011	49463-2011	20
37.65	41.7	34	37	43	494631811	49463-1811	18
33.65	37.7	30	33	39	494631611	49463-1611	16
29.65	33.7	26	29	35	494631411	49463-1411	14
25.65	29.7	22	25	31	494631211	49463-1211	12
21.65	25.7	18	21	27	494631011	49463-1011	10
17.65	21.7	14	17	23	494630811	49463-0811	8
E	D	C	b	A	MATERIAL NO.	ENG. NO.	CKTS.

- NOTE
- MATERIAL
HOUSING : POLYAMIDE GLASS FILLED. UL94-V0. BLACK
TERMINAL · PHOSPHOR BRONZE
 - FINISH
CONTACT- Sn 2 MICROMETER MIN. OVER Ni 1~3 MICROMETER.
 - MISALIGNMENT OF SOLDER TAIL & FITTING NAIL FROM Z:
LOWER DIRECTION 0.1~0.25.
 - CAMBER/BOW OF ALL SECTIONS TO BE 0.15MAX.
 - SOLDER TAIL & FITTING NAIL COPLANARITY BEFORE REFLOW TO BE 0.1MAX. AFTER REFLOW TO BE 0.15MAX.

NEW RELEASE	DESCRIPTION
EC NO: KOR2008-0090	2008/07/11
DRWN:HJEONG	2008/07/11
CHKD:YSOOKIM	2008/07/14
APPR:YUNS IKKIM	
REV	
A	

QUALITY SYMBOLS	GENERAL TOLERANCES (UNLESS SPECIFIED)
▽=0	mm INCH
▽=0	4 PLACES ± --- ± ---
	3 PLACES ± --- ± ---
	2 PLACES ± 0.05 ± ---
	1 PLACE ± 0.1 ± ---
	ANGULAR ± 1°
	DRAFT WHERE APPLICABLE MUST REMAIN WITHIN DIMENSIONS

DIMENSION STYLE		SCALE	DESIGN UNITS	THIRD ANGLE PROJECTION
MM ONLY		5:1	METRIC	
DRAWN BY	DATE	TITLE		
YRKIM	2007/01/24	2.0MM LCD HOUSING ASS'Y SERIES		
CHECKED BY	DATE	MOLEX INCORPORATED		
YSOOKIM	2007/01/24	SD-49463-001		
APPROVED BY	DATE	SHEET NO.		
YSOOKIM	2007/01/24	1 OF 1		
MATERIAL NO.		DOCUMENT NO.		
SEE TABLE		SD-49463-001		
SIZE	THIS DRAWING CONTAINS INFORMATION THAT IS PROPRIETARY TO MOLEX INCORPORATED AND SHOULD NOT BE USED WITHOUT WRITTEN PERMISSION			
A3				

PULL OUT DIRECTION

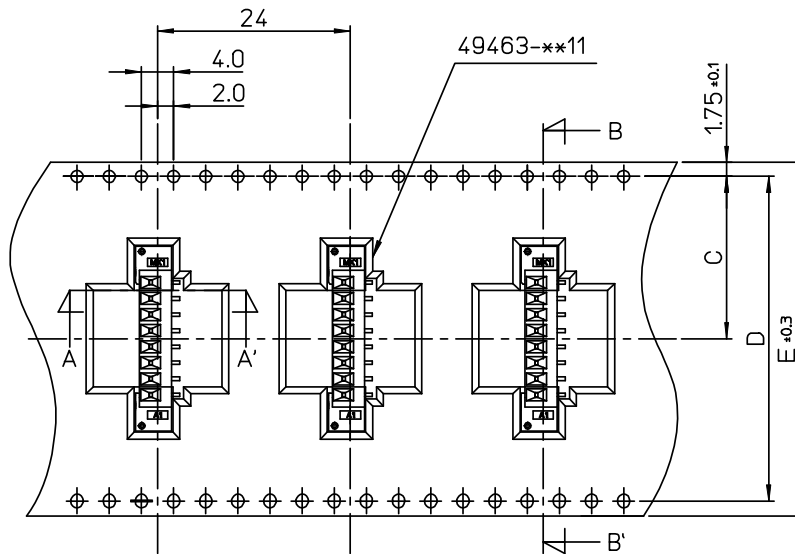

PULL OUT DIRECTION

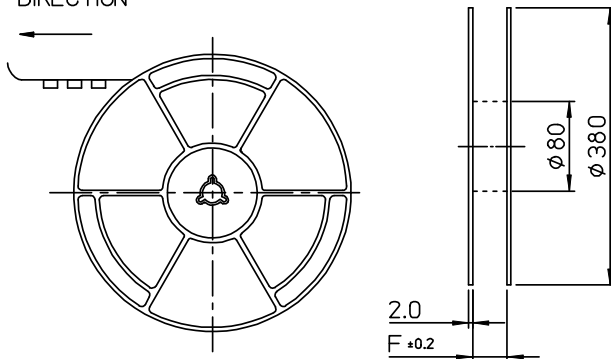

NOTE

1. REFER TO THE DRAWING 49463-**-11 FOR CONNECTOR DIMENSIONS.
2. QUANTITY OF CONNECTORS : 350PCS/REEL
3. LEAD LENGTH

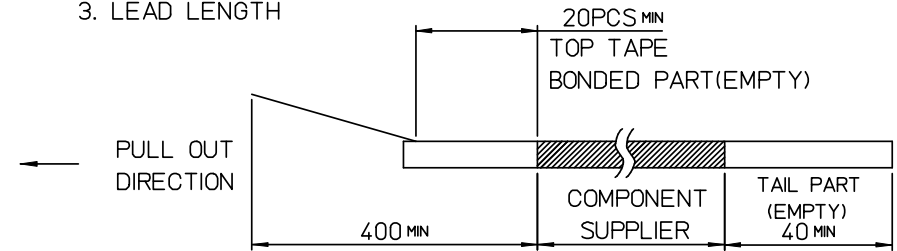

4. PEELING OFF FORCE OF TOP TAPE : 0.1N~0.7N(10.2gf~71.4gf)
(PEELING DIRECTION AS SHOWN IN FOLLOW FIG.)
- THIS REQUIREMENT SHOULD BE APPLIED AT SHIPMENT.
- PEEL OFF SHOULD NOT BE ALLOWED, DURING TRANSPORTATION.

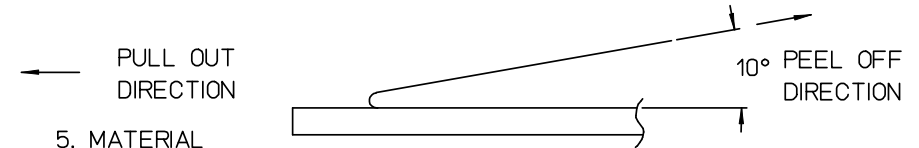

5. MATERIAL
- CARRIER TAPE : P.E.T
- TOP TAPE : P.E.T
- REEL : P.S
6. MATERIAL THICKNESS : 0.4mm
7. ALL CORNER : R 0.2

73.5	72	68.4	34.2	49463-9924	494632417	49463-2417	24
73.5	72	68.4	34.2	49463-9922	494632217	49463-2217	22
73.5	72	68.4	34.2	49463-9920	494632017	49463-2017	20
73.5	72	68.4	34.2	49463-9918	494631817	49463-1817	18
57.5	56	52.4	26.2	49463-9916	494631617	49463-1617	16
57.5	56	52.4	26.2	49463-9914	494631417	49463-1417	14
57.5	56	52.4	26.2	49463-9912	494631217	49463-1217	12
45.5	44	40.4	20.2	49463-9910	494631017	49463-1017	10
45.5	44	40.4	20.2	49463-9908	494630817	49463-0817	8
F	E	D	C	EMBOSS TAPE	MATERIAL NO.	ENG. NO.	CKT

<p>NEW RELEASE EC NO: KOR2008-0090 DRWN: HJEONG 2008/07/11 CHKD: YSOOK IM 2008/07/11 APPR: YUNS IKK IM 2008/07/14</p>	QUALITY SYMBOLS	GENERAL TOLERANCES (UNLESS SPECIFIED)	DIMENSION STYLE	SCALE	DESIGN UNITS	THIRD ANGLE PROJECTION														
	<p>▽=0 ∇=0</p>	<table border="1"> <thead> <tr> <th></th> <th>mm</th> <th>INCH</th> </tr> </thead> <tbody> <tr> <td>4 PLACES</td> <td>± ---</td> <td>± ---</td> </tr> <tr> <td>3 PLACES</td> <td>± ---</td> <td>± ---</td> </tr> <tr> <td>2 PLACES</td> <td>± 0.05</td> <td>± ---</td> </tr> <tr> <td>1 PLACE</td> <td>± 0.1</td> <td>± ---</td> </tr> </tbody> </table>		mm	INCH		4 PLACES	± ---	± ---	3 PLACES	± ---	± ---	2 PLACES	± 0.05	± ---	1 PLACE	± 0.1	± ---	MM ONLY	1.5:1
		mm	INCH																	
	4 PLACES	± ---	± ---																	
3 PLACES	± ---	± ---																		
2 PLACES	± 0.05	± ---																		
1 PLACE	± 0.1	± ---																		
REVISION	DESCRIPTION	<table border="1"> <thead> <tr> <th>DATE</th> <th>BY</th> <th>DATE</th> </tr> </thead> <tbody> <tr> <td>2007/01/24</td> <td>YRKIM</td> <td>2007/01/24</td> </tr> <tr> <td>2007/01/24</td> <td>YSOOK IM</td> <td>2007/01/24</td> </tr> <tr> <td>2007/01/24</td> <td>YSOOK IM</td> <td>2007/01/24</td> </tr> </tbody> </table>	DATE	BY	DATE	2007/01/24	YRKIM	2007/01/24	2007/01/24	YSOOK IM	2007/01/24	2007/01/24	YSOOK IM	2007/01/24	TITLE		<p>2.0MM LCD HOUSING ASS'Y SERIES EMBOSSED TAPE PACKAGE</p>			
DATE	BY	DATE																		
2007/01/24	YRKIM	2007/01/24																		
2007/01/24	YSOOK IM	2007/01/24																		
2007/01/24	YSOOK IM	2007/01/24																		
A		<p>ANGULAR ± 1 °</p>	<p>MOLEX MOLEX INCORPORATED</p>																	
DRAFT WHERE APPLICABLE MUST REMAIN WITHIN DIMENSIONS			MATERIAL NO.	DOCUMENT NO.	SHEET NO.															
			SEE TABLE	SD-49463-002	1 OF 1															
<p>THIS DRAWING CONTAINS INFORMATION THAT IS PROPRIETARY TO MOLEX INCORPORATED AND SHOULD NOT BE USED WITHOUT WRITTEN PERMISSION</p>																				