

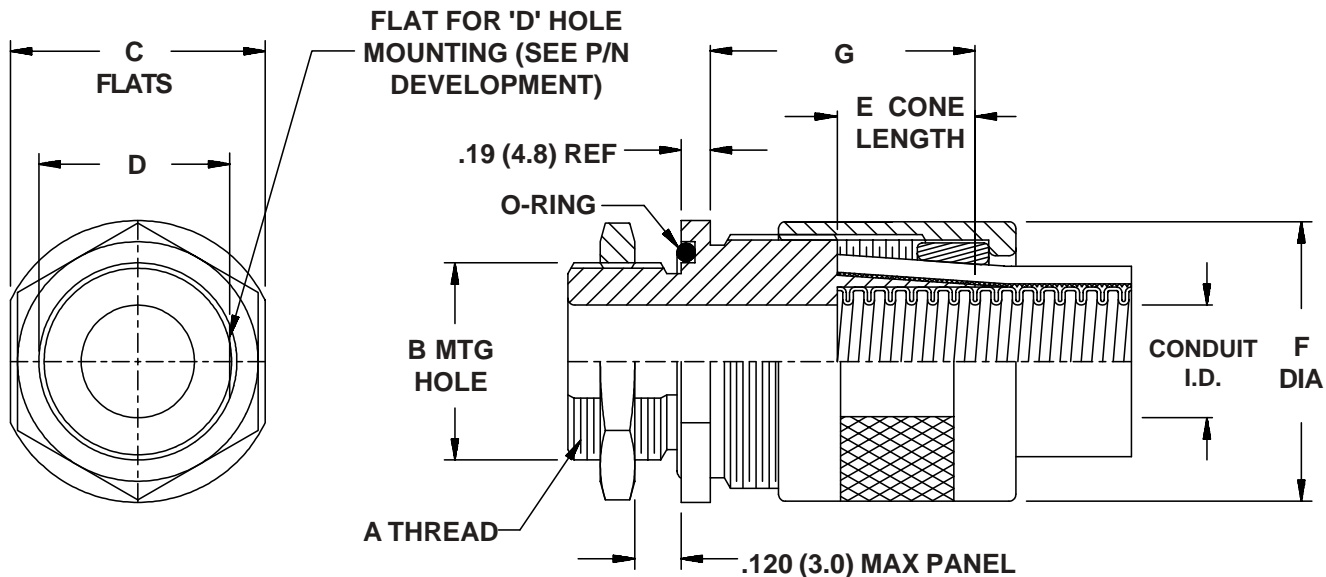

712-188 Environmental User-Installable Bulkhead Fitting for Series 75 Flexible Metal-Core Conduit

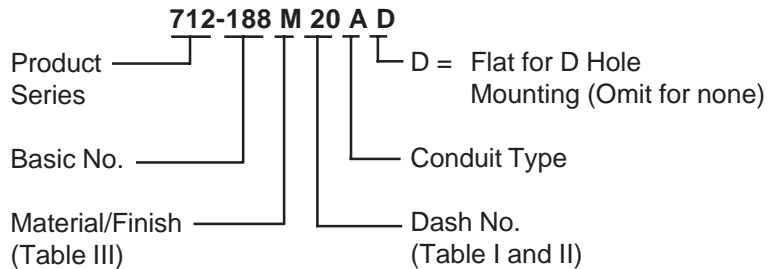

712-188
Environmental User-Installable Bulkhead Fitting
for Series 75 Flexible Metal-Core Conduit



TABLE I

DASH NO.	CONDUIT I.D.	A THREAD CLASS 2A	B DIA		C FLATS	D DIA	
			+0.030 (0.8)	-0.000 (0.0)		+0.000 (0.0)	-0.015 (0.4)
08	.250 (6.4)	1/2 - 20 UNF	.50 (12.7)		.750 (19.1)	.438 (11.1)	
12	.375 (9.5)	5/8 - 24 UNEF	.63 (16.0)		.875 (22.2)	.563 (14.3)	
16	.500 (12.7)	3/4 - 20 UNEF	.75 (19.1)		1.000 (25.4)	.688 (17.5)	
20	.625 (15.9)	7/8 - 20 UNEF	.88 (22.4)		1.125 (28.6)	.812 (20.6)	
24	.750 (19.1)	1 - 20 UNEF	1.00 (25.4)		1.250 (31.8)	.938 (23.8)	
32	1.000 (25.4)	1 5/16 - 18 UNEF	1.32 (33.5)		1.562 (39.7)	1.250 (31.8)	
40	1.250 (31.8)	1 1/2 - 18 UNEF	1.50 (38.1)		1.812 (46.0)	1.438 (36.5)	
48	1.500 (38.1)	1 3/4 - 18 UNS	1.75 (44.5)		2.062 (52.4)	1.688 (42.9)	
56	1.750 (44.5)	2 - 18 UNS	2.00 (50.8)		2.312 (58.7)	1.938 (49.2)	
64	2.000 (50.8)	2 1/4 - 16 UN	2.25 (57.2)		2.562 (65.1)	2.188 (55.6)	
80	2.500 (63.5)	2 3/4 - 16 UN	2.75 (69.9)		3.062 (77.8)	2.688 (68.3)	
96	3.000 (76.2)	3 1/4 - 16 UN	3.25 (82.6)		3.562 (90.5)	3.188 (81.0)	

TABLE II

DASH NO.	E	F MAX (NOTE 2)	G
08	.75 (19.1)	1.16 (29.5)	1.39 (35.3)
12	.75 (19.1)	1.34 (34.0)	1.39 (35.3)
16	.75 (19.1)	1.46 (37.1)	1.39 (35.3)
20	.75 (19.1)	1.65 (41.9)	1.39 (35.3)
24	.75 (19.1)	1.84 (46.7)	1.39 (35.3)
32	1.00 (25.4)	2.02 (51.3)	1.64 (41.7)
40	1.00 (25.4)	2.34 (59.4)	1.64 (41.7)
48	1.00 (25.4)	2.72 (69.0)	1.64 (41.7)
56	1.00 (25.4)	2.96 (75.2)	1.64 (41.7)
64	1.00 (25.4)	3.22 (81.8)	1.64 (41.7)
80	1.00 (25.4)	3.86 (98.0)	1.64 (41.7)
96	1.00 (25.4)	4.38(111.3)	1.64 (41.7)

NOTES:

1. Metric dimensions (mm), are in parentheses.
2. F dimensions are based on type A construction. Add .125 (3.2) to listed dimensions for each additional shield types B through D.

TABLE III

SYMBOL	MATERIAL	FINISH
A	Aluminum Alloy, 6061-T6 per QQ-A-225/8	Cadmium, Olive Drab, per QQ-P-416, over Electroless Nickel per ASTM B733-90, and MIL-C-26074, 500 Hour Salt Spray
B	Brass, ASTM B16 per QQ-B-626	
C	Corrosion Resistant Steel per QQ-S-763, 300 Series	Passivate per QQ-P-35
M	Aluminum Alloy, 6061-T6 per QQ-A-225/8	Electroless Nickel per ASTM B733-90 and MIL-C-26074
NC	Aluminum Alloy, 6061-T6 per QQ-A-225/8	Zinc Cobalt, Olive Drab
S	Carbon Steel, B1113, per QQ-S-637	Cadmium, Olive Drab per QQ-P-416, over Electroless Nickel per ASTM B733-90 and MIL-C-26074, 500 Hour Salt Spray