

HSMx-C265

Surface Mount Chip LEDs

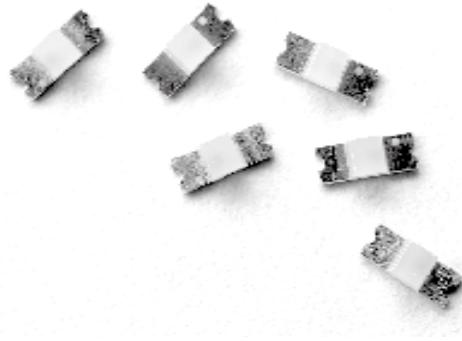

Data Sheet



Description

The HSMx-C265 is a reverse mountable chip-type LED for lighting the non-component side of a PCB board. In this reverse mounting configuration, this LED is designed to emit light through a small cut-out hole in the PC board.

The HSMx-C265 is available in four colors. The small size, narrow footprint, and low profile make this series of LEDs excellent for backlighting, status indication, and front panel illumination application.

Features

- Reverse mountable
- Undiffused optics
- Small 3.4 x 1.25 mm footprint
- Operating temperature range of -30°C to $+85^{\circ}\text{C}$
- Compatible with IR solder reflow
- Four colors available: red, orange, yellow, and green
- Available in 8 mm tape on 7" (178 mm) diameter reels

Applications

- Keypad backlighting
- Symbol backlighting
- LCD backlighting
- Status indication

Device Selection Guide

Part Number	Color	Parts Per Reel
HSMS-C265	High Efficiency Red	3000
HSMD-C265	Orange	3000
HSMY-C265	Yellow	3000
HSMG-C265	Green	3000
HSMH-C265	AlGaAs Red	3000

Package Dimensions

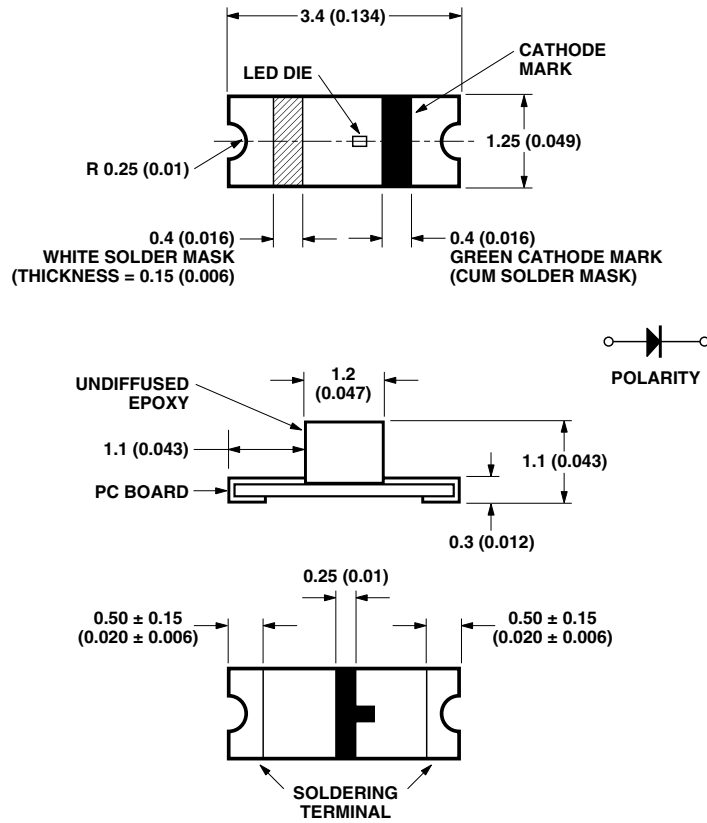

Notes:

1. All dimensions in millimeters (inches).
2. Tolerance is ± 0.1 mm (± 0.004 in.) unless otherwise specified.
3. Polarity of HSMH-C265 will be the opposite of what is shown on above drawing.

Absolute Maximum Ratings

$T_A = 25^\circ\text{C}$

Parameter	HSMH-C265	HSMH-C265	Units
DC Forward Current ^[1]	25	25	mA
Peak Pulsing Current ^[2]	100	100	mA
Power Dissipation	65	65	mW
Reverse Voltage ($I_R = 100 \mu\text{A}$)	5	5	V
Led Junction Temperature	95	95	$^\circ\text{C}$
Operating Temperature Range	-30 to +85	-30 to +85	$^\circ\text{C}$
Storage Temperature Range	-40 to +85	-40 to +85	$^\circ\text{C}$
Soldering Temperature	See IR soldering profile (Figure 6)		

Notes:

1. Derate linearly as shown in Figure 4.
2. Pulse condition of 1/10 duty and 0.1 msec. width.

Electrical Characteristics

$T_A = 25^\circ\text{C}$

Part Number	Forward Voltage V_F (Volts) @ $I_F = 20\text{ mA}$		Reverse Breakdown V_R (Volts) @ $I_R = 100\ \mu\text{A}$	Capacitance C (pF), $V_F = 0$, $f = 1\text{ MHz}$	Thermal Resistance $R\theta_{J-PIN}$ ($^\circ\text{C/W}$)
	Typ.	Max.	Min.	Typ. ^[1]	Typ.
HSMS-C265	2.1	2.6	5	8	250
HSMD-C265	2.2	2.6	5	6	250
HSMY-C265	2.1	2.6	5	7	250
HSMG-C265	2.2	2.6	5	6	250
HSMH-C265	1.8	2.6	5	18	300

Optical Characteristics

$T_A = 25^\circ\text{C}$

Part Number	Color	Luminous Intensity I_v (mcd) @ 20 mA ^[1]		Peak Wavelength λ_{peak} (nm)	Dominant Wavelength λ_d (nm) ^[2]	Viewing Angle $2\theta_{1/2}$ Degrees ^[3]
		Min.	Typ.	Typ.	Typ.	Typ.
HSMS-C265	HER	2.5	10.0	630	626	150
HSMD-C265	Orange	2.5	8.0	605	604	150
HSMY-C265	Yellow	2.5	8.0	589	586	150
HSMG-C265	Green	4.0	15.0	570	572	150
HSMH-C265	AlGaAs	6.3	17.0	660	639	150

Notes:

1. The luminous intensity, I_v , is measured at the peak of the spatial radiation pattern which may not be aligned with the mechanical axis of the lamp package.
2. The dominant wavelength, λ_d , is derived from the CIE Chromaticity Diagram and represent the perceived color of the device.
3. $\theta_{1/2}$ is the off-axis angle where the luminous intensity is 1/2 the peak intensity.

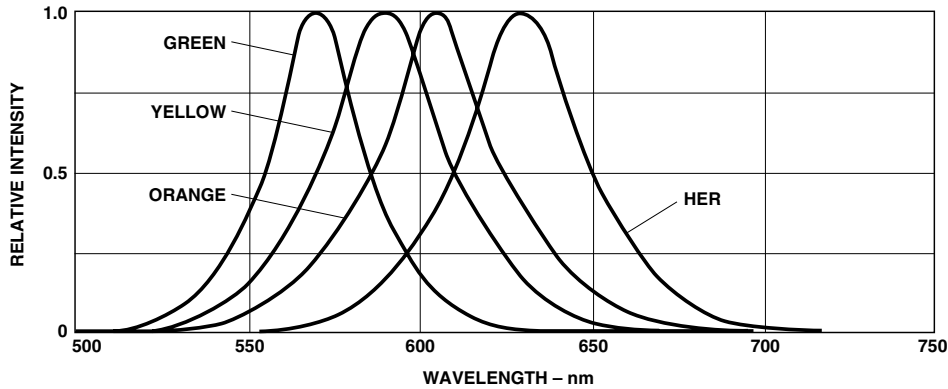

Figure 1. Relative intensity vs. wavelength.

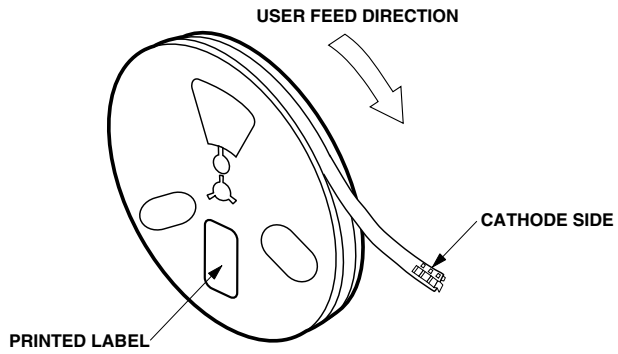

Figure 8. Reeling orientation.

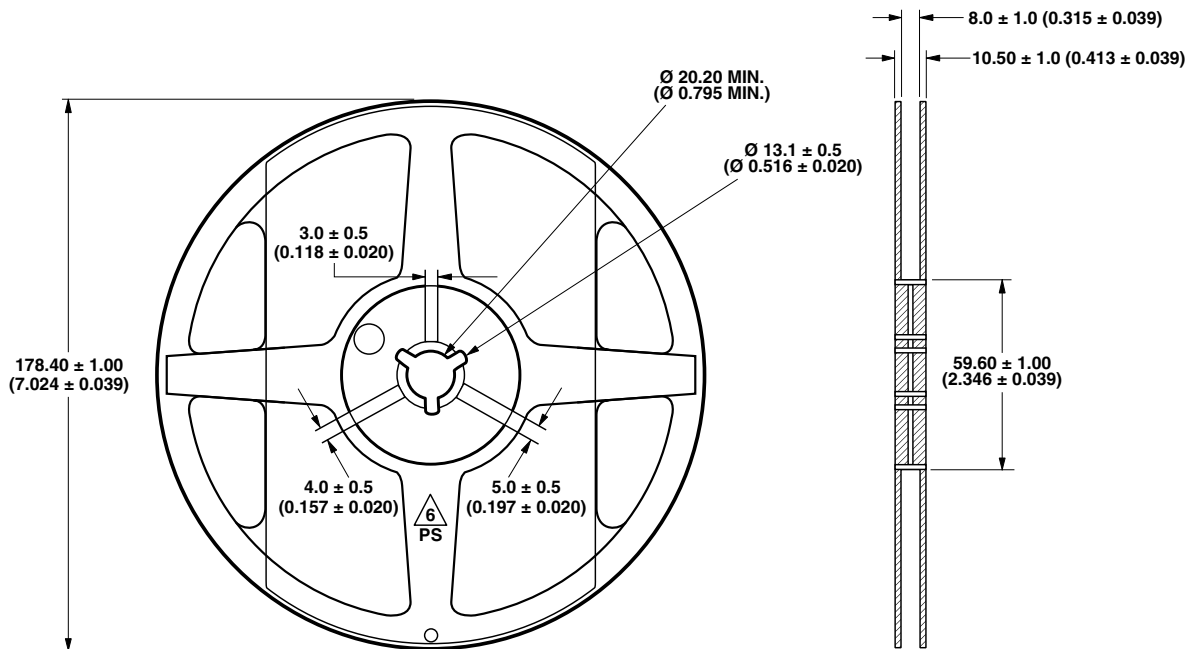

Figure 9. Reel Dimensions.

Note:

1. All dimensions in millimeters (inches).

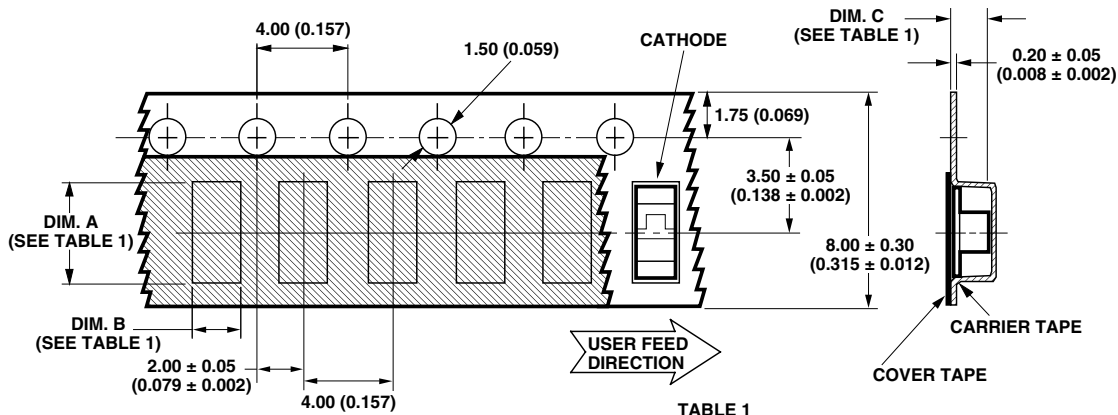
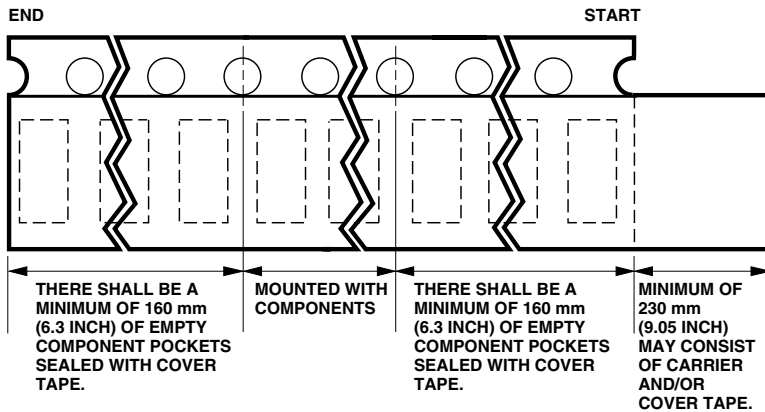

TABLE 1
DIMENSIONS IN MILLIMETERS (INCHES)

PART NUMBER	DIM. A ± 0.10 (0.004)	DIM. B ± 0.10 (0.004)	DIM. C ± 0.10 (0.004)
HSMx-C265 SERIES	3.70 (0.146)	1.45 (0.057)	1.30 (0.051)

Figure 10. Tape dimensions.



Convective IR Reflow Soldering
For more information on IR reflow soldering, refer to Application Note 1060, Surface Mounting SMT LED Indicator Components.

Figure 11. Tape leader and trailer dimensions.

Notes:

1. All dimensions in millimeters (inches).
2. Tolerance is ± 0.1 mm (± 0.004 in.) unless otherwise specified.

Storage Condition: 5 to 30°C at 60% RH max.

Baking is required under the condition:

- a) the blue silica gell indicator becoming white/transpar-ent color
- b) the pack has been open for more than 1 week

Baking recommended condition: 60 \pm 5°C for 20 hours.

For product information and a complete list of distributors, please go to our website: www.avagotech.com

Avago, Avago Technologies, and the A logo are trademarks of Avago Technologies, Pte. in the United States and other countries.
Data subject to change. Copyright © 2006 Avago Technologies Pte. All rights reserved. Obsoletes 5980-1655E
5980-2435E November 27, 2007

