



## PACDN006

### Features

- Six channels of ESD protection
- $\pm 8\text{kV}$  contact,  $\pm 15\text{kV}$  air ESD protection per channel (IEC 61000-4-2 standard)
- $\pm 15\text{kV}$  of ESD protection per channel (HBM)
- Low loading capacitance (3pF typical)
- Low leakage current is ideal for battery-powered devices
- Available in miniature 8-pin MSOP and 8-pin SOIC packages
- RoHS compliant (lead-free) finishing

### Applications

- Consumer electronic products
- Cellular phones
- PDAs
- Notebook computers
- Desktop PCs
- Digital cameras and camcorders
- VGA (video) port protection for desktop and portable PCs

### Product Description

The PACDN006 is a diode array designed to provide six channels of ESD protection for electronic components or subsystems. Each channel consists of a pair of diodes that steer an ESD current pulse to either the positive ( $V_p$ ) or negative ( $V_n$ ) supply. The PACDN006 protects against ESD pulses up to:

- $\pm 8\text{kV}$  contact discharge, per International Standard IEC 61000-4-2
- $\pm 15\text{kV}$  per Human Body Model MIL-STD-883, Method 3015 (based on a 100 pF capacitor discharging through a 1.5K $\Omega$  resistor)

This device is particularly well-suited for portable electronics (e.g., cellular phones, PDAs, notebook computers) because of its small package footprint, high ESD protection level, and low loading capacitance. It is also suitable for protecting video output lines and I/O ports in computers and peripherals and is ideal for a wide range of consumer electronics products.

The PACDN006 is available with RoHS compliant lead-free finishing.

**Typical Application Circuit**

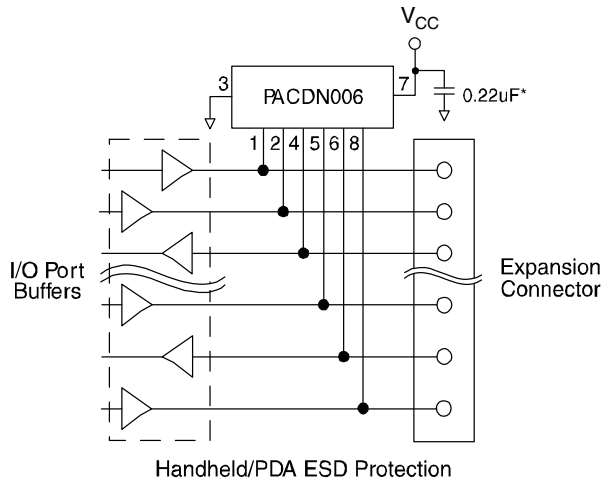

\* Decoupling capacitor must be placed as close as possible to Pin7.

**Electrical Schematic**

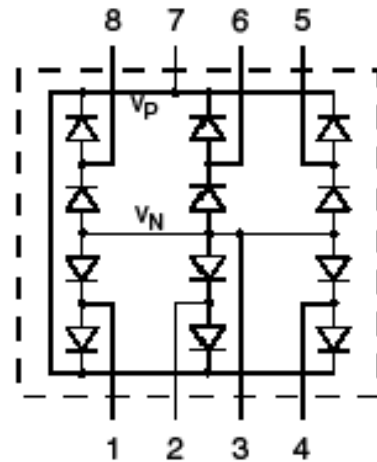

**PACKAGE / PINOUT DIAGRAMS**

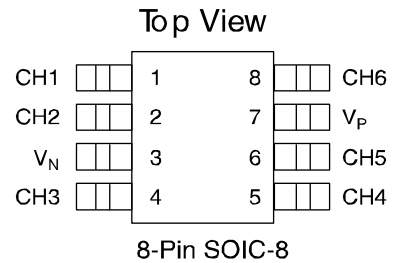
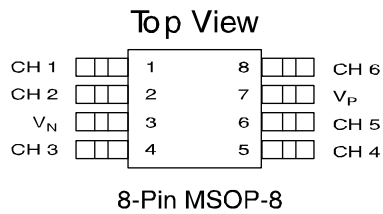

Note: These drawing are not to scale.

# PACDN006

## PIN DESCRIPTIONS

PIN	NAME	TYPE	DESCRIPTION
1	CH 1	I/O	ESD Channel
2	CH 2	I/O	ESD Channel
3	$V_N$	GND	Negative voltage supply rail or ground reference rail
4	CH 3	I/O	ESD Channel
5	CH 4	I/O	ESD Channel
6	CH 5	I/O	ESD Channel
7	$V_P$	Supply	Positive voltage supply rail
8	CH 6	I/O	ESD Channel

## Ordering Information

### PART NUMBERING INFORMATION

Pins	Package	Ordering Part Number <sup>1</sup>	Part Marking
8	MSOP	PACDN006MR	006R
8	SOIC	PACDN006SM	PACDN 006SM

Note 1: Parts are shipped in Tape and Reel form unless otherwise specified.

## Specifications

### ABSOLUTE MAXIMUM RATINGS

PARAMETER	RATING	UNITS
Supply Voltage ( $V_P - V_N$ )	6.0	V
Diode Forward DC Current (Note 1)	20	mA
Operating Temperature Range	-40 to +85	°C
Storage Temperature Range	-65 to +150	°C
DC Voltage at any channel input	$(V_N - 0.5)$ to $(V_P + 0.5)$	V
Package Power Rating	200	mW

Note 1: Only one diode conducting at a time.

### STANDARD OPERATING CONDITIONS

PARAMETER	RATING	UNITS
Operating Temperature Range	-40 to +85	°C
Operating Supply Voltage ( $V_P - V_N$ )	0 to 5.5	V

### ELECTRICAL OPERATING CHARACTERISTICS<sup>(SEE NOTE 1)</sup>

SYMBOL	PARAMETER	CONDITIONS	MIN	TYP	MAX	UNITS
$I_P$	Supply Current	$(V_P - V_N) = 5.5V$			10	$\mu A$
$V_F$	Diode Forward Voltage	$I_F = 20mA$	0.65		0.95	V
$V_{ESD}$	ESD Protection Peak Discharge Voltage at any channel input, in system a) Human Body Model, MIL-STD-883, Method 3015 b) Contact Discharge per IEC 61000-4-2 c) Air Discharge per IEC 61000-4-2	Note 2 Note 3 Note 4 Note 4		$\pm 15$ $\pm 8$ $\pm 15$		kV kV kV
$V_{CL}$	Channel Clamp Voltage Positive Transients Negative Transients	@ 15kV ESD HBM			$V_P + 13.0$ $V_N - 13.0$	V V
$I_{LEAK}$	Channel Leakage Current			$\pm 0.1$	$\pm 1.0$	$\mu A$
$C_{IN}$	Channel Input Capacitance	@ 1 MHz, $V_P = 5V$ , $V_N = 0V$ , $V_{IN} = 2.5V$		3	5	pF

Note 1: All parameters specified at  $T_A = 25^\circ C$  unless otherwise noted.  $V_P = 5V$ ,  $V_N = 0V$  unless noted.

Note 2: From I/O pins to  $V_P$  or  $V_N$  only.  $V_P$  bypassed to  $V_N$  with a 0.22 $\mu F$  ceramic capacitor (see Application Information for more details).

Note 3: Human Body Model per MIL-STD-883, Method 3015,  $C_{Discharge} = 100pF$ ,  $R_{Discharge} = 1.5K\Omega$ ,  $V_P = 5.0V$ ,  $V_N$  grounded.

Note 4: Standard IEC 61000-4-2 with  $C_{Discharge} = 150pF$ ,  $R_{Discharge} = 330\Omega$ ,  $V_P = 5.0V$ ,  $V_N$  grounded.

## Performance Information

### Input Capacitance vs. Input Voltage

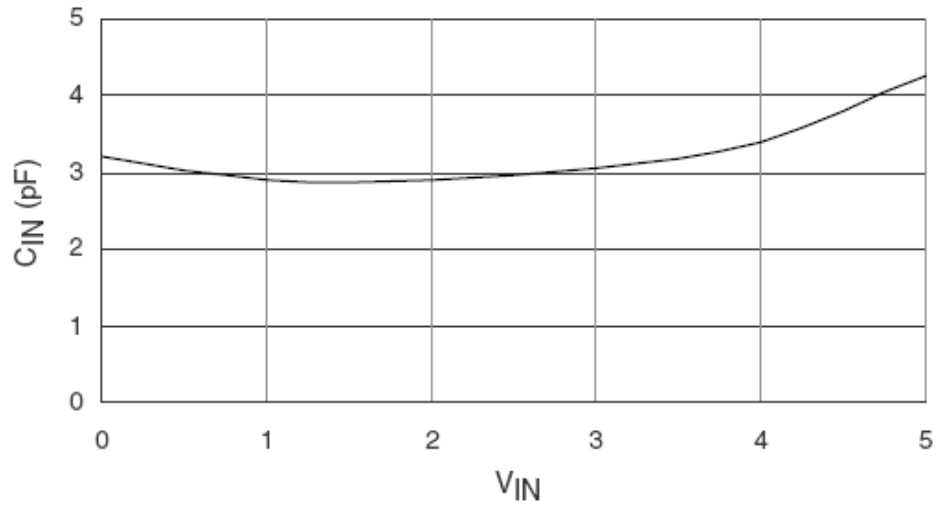

### Typical Variation of $C_{IN}$ vs. $V_{IN}$

( $V_P = 5V$ ,  $V_N = 0V$ ,  $0.1 \mu F$  chip capacitor between  $V_P$  and  $V_N$ )

## Application Information

### Design Considerations

In order to realize the maximum protection against ESD pulses, care must be taken in the PCB layout to minimize parasitic series inductances on the Supply/Ground rails as well as the signal trace segment between the signal input (typically a connector) and the ESD protection device. Refer to [Figure 1](#), which illustrates an example of a positive ESD pulse striking an input channel. The parasitic series inductance back to the power supply is represented by  $L_1$  and  $L_2$ . The voltage  $V_{CL}$  on the line being protected is:

$$V_{CL} = \text{Fwd voltage drop of D}_1 + V_{\text{SUPPLY}} + L_1 \times d(I_{\text{ESD}}) / dt + L_2 \times d(I_{\text{ESD}}) / dt$$

where  $I_{\text{ESD}}$  is the ESD current pulse, and  $V_{\text{SUPPLY}}$  is the positive supply voltage.

An ESD current pulse can rise from zero to its peak value in a very short time. As an example, a level 4 contact discharge per the IEC61000-4-2 standard results in a current pulse that rises from zero to 30 Amps in 1ns. Here  $d(I_{\text{ESD}})/dt$  can be approximated by  $\Delta I_{\text{ESD}}/\Delta t$ , or  $30/(1 \times 10^{-9})$ . So just 10nH of series inductance ( $L_1$  and  $L_2$  combined) will lead to a 300V increment in  $V_{CL}$ !

Similarly for negative ESD pulses, parasitic series inductance from the  $V_N$  pin to the ground rail will lead to drastically increased negative voltage on the line being protected.

Another consideration is the output impedance of the power supply for fast transient currents. Most power supplies exhibit a much higher output impedance to fast transient current spikes. In the  $V_{CL}$  equation above, the  $V_{\text{SUPPLY}}$  term, in reality, is given by  $(V_{\text{DC}} + I_{\text{ESD}} \times R_{\text{OUT}})$ , where  $V_{\text{DC}}$  and  $R_{\text{OUT}}$  are the nominal supply DC output voltage and effective output impedance of the power supply respectively. As an example, a  $R_{\text{OUT}}$  of 1 ohm would result in a 10V increment in  $V_{CL}$  for a peak  $I_{\text{ESD}}$  of 10A.

If the inductances and resistance described above are close to zero, the rail-clamp ESD protection diodes will do a good job of protection. However, since this is not possible in practical situations, a bypass capacitor must be used to absorb the very high frequency ESD energy. So for any brand of rail-clamp ESD protection diodes, a bypass capacitor should be connected between the  $V_P$  pin of the diodes and the ground plane ( $V_N$  pin of the diodes) as shown in the Application Circuit diagram below. A value of 0.22 $\mu$ F is adequate for IEC-61000-4-2 level 4 contact discharge protection ( $\pm 8$ kV). Ceramic chip capacitors mounted with short printed circuit board traces are good choices for this application. Electrolytic capacitors should be avoided as they have poor high frequency characteristics. For extra protection, connect a zener diode in parallel with the bypass capacitor to mitigate the effects of the parasitic series inductance inherent in the capacitor. The breakdown voltage of the zener diode should be slightly higher than the maximum supply voltage.

As a general rule, the ESD Protection Array should be located as close as possible to the point of entry of expected electrostatic discharges. The power supply bypass capacitor mentioned above should be as close to the  $V_P$  pin of the Protection Array as possible, with minimum PCB trace lengths to the power supply, ground planes and between the signal input and the ESD device to minimize stray series inductance.

### Additional Information

See also California Micro Devices Application Notes AP209, "Design Considerations for ESD Protection" and AP219, "ESD Protection for USB 2.0 Systems"

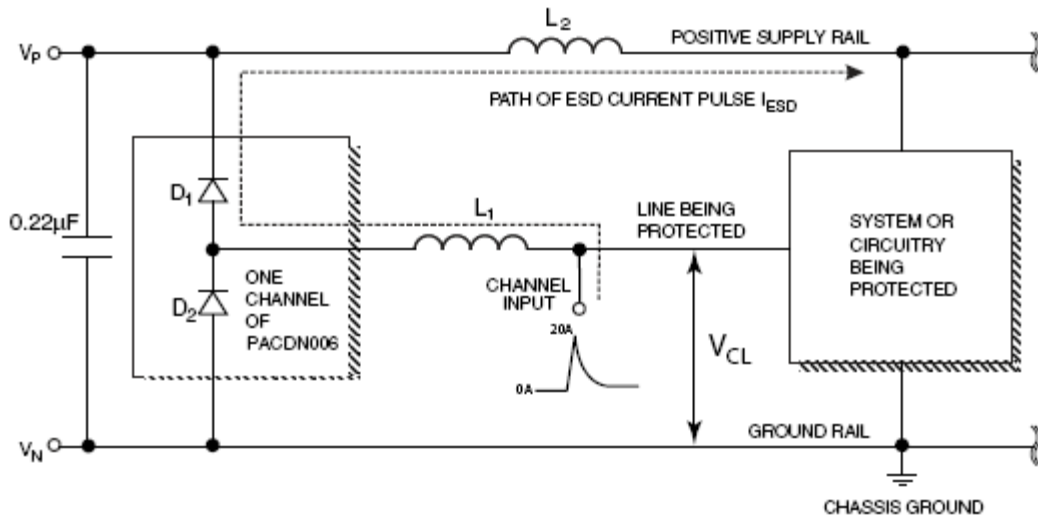

Figure 1. Application of Positive ESD Pulse between Input Channel and Ground

## Mechanical Details

The PACDN006 is supplied in a 8-pin MSOP package and the SOIC package.

### MSOP-8 Mechanical Specifications, 8 pin

The 8-pin MSOP package dimensions are presented below.

PACKAGE DIMENSIONS				
Package	MSOP			
Pins	8			
Dimensions	Millimeters		Inches	
	Min	Max	Min	Max
<b>A</b>	0.75	0.95	0.030	0.037
<b>A1</b>	0.05	0.15	0.002	0.006
<b>B</b>	0.28	0.38	0.011	0.015
<b>C</b>	0.13	0.23	0.005	0.009
<b>D</b>	2.90	3.10	0.114	0.122
<b>E</b>	2.90	3.10	0.114	0.122
<b>e</b>	0.65 BSC		0.026 BSC	
<b>H</b>	4.90 BSC		0.193 BSC	
<b>L</b>	0.40	0.70	0.016	0.028
<b># per tape and reel</b>	4000 pieces			
Controlling dimension: millimeters				

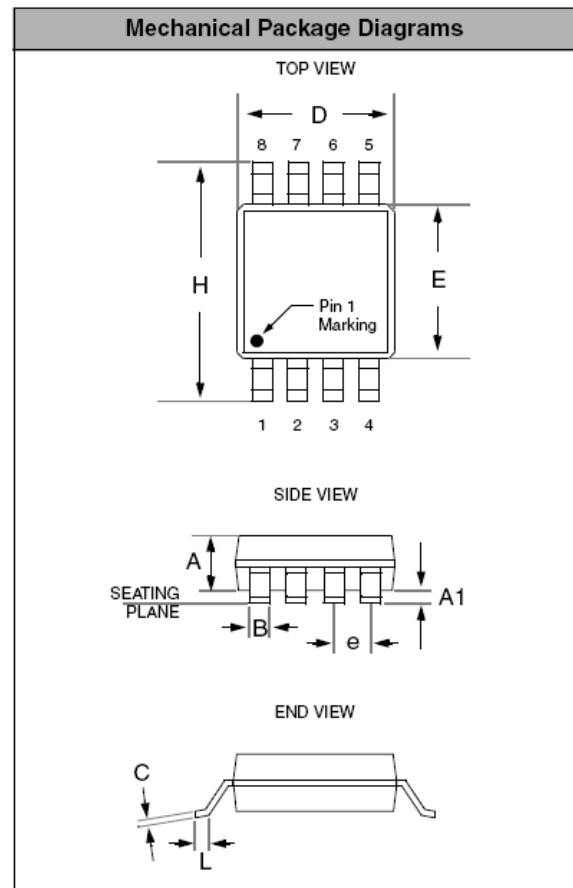



ON Semiconductor and  are registered trademarks of Semiconductor Components Industries, LLC (SCILLC). SCILLC reserves the right to make changes without further notice to any products herein. SCILLC makes no warranty, representation or guarantee regarding the suitability of its products for any particular purpose, nor does SCILLC assume any liability arising out of the application or use of any product or circuit, and specifically disclaims any and all liability, including without limitation special, consequential or incidental damages. "Typical" parameters which may be provided in SCILLC data sheets and/or specifications can and do vary in different applications and actual performance may vary over time. All operating parameters, including "Typicals" must be validated for each customer application by customer's technical experts. SCILLC does not convey any license under its patent rights nor the rights of others. SCILLC products are not designed, intended, or authorized for use as components in systems intended for surgical implant into the body, or other applications intended to support or sustain life, or for any other application in which the failure of the SCILLC product could create a situation where personal injury or death may occur. Should Buyer purchase or use SCILLC products for any such unintended or unauthorized application, Buyer shall indemnify and hold SCILLC and its officers, employees, subsidiaries, affiliates, and distributors harmless against all claims, costs, damages, and expenses, and reasonable attorney fees arising out of, directly or indirectly, any claim of personal injury or death associated with such unintended or unauthorized use, even if such claim alleges that SCILLC was negligent regarding the design or manufacture of the part. SCILLC is an Equal Opportunity/Affirmative Action Employer. This literature is subject to all applicable copyright laws and is not for resale in any manner.

**PUBLICATION ORDERING INFORMATION**

**LITERATURE FULFILLMENT:**

Literature Distribution Center for ON Semiconductor  
P.O. Box 5163, Denver, Colorado 80217 USA  
**Phone:** 303-675-2175 or 800-344-3860 Toll Free USA/Canada  
**Fax:** 303-675-2176 or 800-344-3867 Toll Free USA/Canada  
**Email:** [orderlit@onsemi.com](mailto:orderlit@onsemi.com)

**N. American Technical Support:** 800-282-9855  
Toll Free USA/Canada  
**Europe, Middle East and Africa Technical Support:**  
Phone: 421 33 790 2910  
**Japan Customer Focus Center**  
Phone: 81-3-5773-3850

ON Semiconductor Website: [www.onsemi.com](http://www.onsemi.com)  
Order Literature: <http://www.onsemi.com/orderlit>  
For additional information, please contact your local Sales Representative