

## Long Life 12mm Diameter, Single-Turn, Carbon Panel Controls

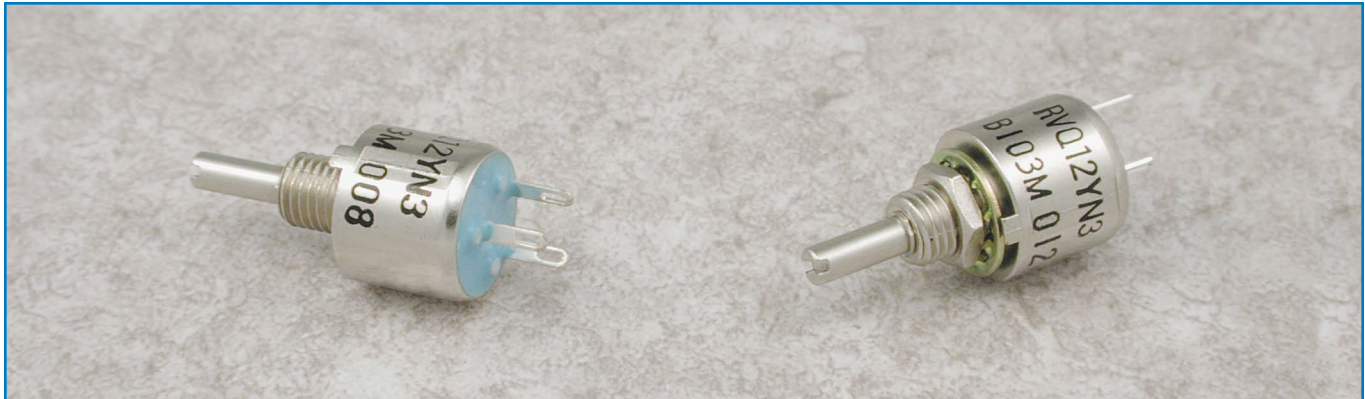

### Features

- Long life 12mm diameter, single-turn industrial panel controls
- Carbon film element
- 50,000 cycle rotational life
- Single unit, single shaft
- Zinc alloy housing and bushing
- Suitable for high power applications
- 3.2mm diameter metal shafts in slot, flat or round end styles
- Standard 10mm or 15mm shaft length
- Linear taper
- Panel mount style
- Rear exit vertical lug terminals
- PCB mounting style available as special order

### Specifications

#### Electrical

<b>Standard Resistance Range</b> .....	1k $\Omega$ to 1M $\Omega$
<b>Resistance Tolerance</b> .....	$\pm$ 20% standard
<b>End Resistance</b> .....	3 $\Omega$ max.
<b>Resistance Taper</b> .....	B = linear
<b>Independent Linearity</b> .....	Not applicable
<b>Peak Noise (C.R.V.)</b> .....	2% max.
<b>Power Rating</b> .....	0.5 watt at +40°C, 0 watt at +85°C
<b>Maximum Input Voltage</b> .....	300VDC or power rating, whichever is smaller
<b>Insulation Resistance</b> .....	100M $\Omega$ minimum at 500VDC
<b>Dielectric Strength</b> .....	500VAC, 1 minute
<b>Adjustment Travel</b> .....	Not applicable

#### Mechanical

<b>Mechanical Travel</b> .....	300° $\pm$ 10°
<b>Shaft Torque</b> .....	20 to 200 gf•cm (0.28 to 2.77 oz•in)
<b>Stop Strength</b> .....	2.5 kgf•cm (34.66 oz•in) min.
<b>Shaft Strength (push)</b> .....	29.4 N (3 kgf) min.
<b>Shaft Strength (tensile)</b> .....	9.8 N (1 kgf) min.
<b>Shaft End Play</b> .....	$\pm$ 0.3 $\times$ (shaft length/15) mm max.
<b>Mounting Nut Torque</b> .....	3 kgf•cm (41.59 oz•in) min.
<b>Marking</b> .....	Model type, taper, resistance code, date code

#### Environmental

<b>Temperature Range</b> .....	-10°C to +85°C
<b>Temperature Characteristics</b> .....	+85°C, 5 hours $\Delta$ T/R $\leq$ $\pm$ 10%
<b>Temperature Cycle</b> .....	-10°C, +85°C, 30 minutes each, 5 cycles $\Delta$ T/R $\leq$ $\pm$ 10%
<b>Load Life</b> .....	+40°C, 0.5 watt, 1,000 hours $\Delta$ T/R $\leq$ $\pm$ 10%
<b>Moisture and Load Life</b> .....	+40°C, 90-95% RH, 0.5 watt, 500 hours $\Delta$ T/R $\leq$ $\pm$ 10%
<b>Vibration</b> .....	10-55Hz, 1.5mm amplitude, 3 directions $\Delta$ T/R $\leq$ $\pm$ 2.5%
<b>Soldering Heat Resistance</b> .....	350°C $\pm$ 5°C, 3 seconds $\Delta$ T/R $\leq$ $\pm$ 2%
<b>Rotational Life</b> .....	50,000 cycles without load $\Delta$ T/R $\leq$ $\pm$ 10%

$\Delta$ T/R = Total Resistance Change

Note: A long life panel control should only be used in a circuit as a potentiometer (3-terminal voltage divider).

**RVQ12YN3**

Panel Mount, Single Unit, Single Shaft

Rear Exit Vertical Lug Terminals, 3-Lug Triangular Pattern

Unit: mm

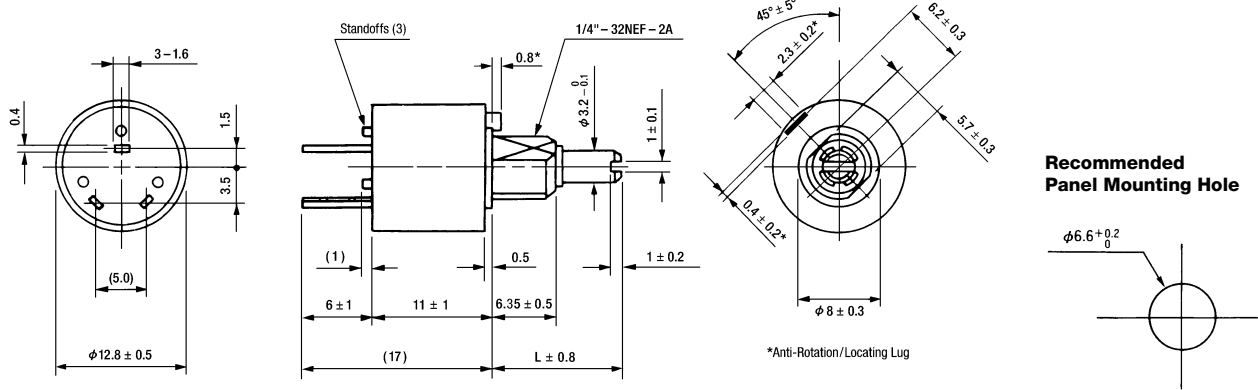

**Recommended Panel Mounting Hole**

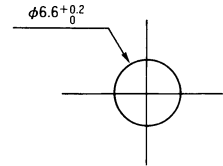

**Part Numbering System**

**RV Q 12 Y N 3 15 S B 103 M**

NOTE: FMS = From Mounting Surface

- **Resistance Tolerance: M** = ±20% (standard).
- **Resistance Code:** Expressed in ohms. A three digit code where the first two digits are significant figures, and the third digit indicates the number of zeros that follow these figures (i.e., 100 = 10Ω; 101 = 100Ω; 102 = 1,000Ω; 103 = 10,000Ω; 105 = 1,000,000Ω). See table for standard resistance values.
- **Resistance Taper: B** = Linear.
- **Shaft End Style: S** = Slotted.  
**F** = Flatted.  
**R** = Round.
- **Standard Shaft Length: 10** = 10mm FMS; **15** = 15mm FMS.  
 Up to 30mm shaft length available (special order).
- **Design Type: 3** = Design Variation of 12mm Size.
- **Style: N** = Panel Mount, Single Unit, Single Shaft, Rear Exit Vertical Lug Terminals, 3-Lug Triangular Pattern (standard).  
**P** = PCB Mount, Single Unit, Single Shaft, Rear Exit Vertical Mount Pin Terminals, 3-Pin Triangular Pattern (special order).
- **Operating Temperature Range: Y** = -10°C to +85°C.
- **Size: 12** = 12mm Diameter.
- **Rotational Life: Q** = Long Life, 50,000 cycles.
- **TOCOS Series Name: RV** = Carbon Film Element.

**Standard Resistance Values and Part Numbering Codes**

**Standard Nominal Total Resistance Values and Part Numbering Codes**

Resistance (Ω)	Code	Resistance (Ω)	Code	Resistance (Ω)	Code	Resistance (Ω)	Code
1,000	102	10,000	103	100,000	104	1,000,000	105
2,000	202	20,000	203	200,000	204		
5,000	502	50,000	503	500,000	504		

Refer to Shaft End Styles Specifications and Hardware Specifications for details and availability.  
 For additional information, refer to Guidelines and Precautions for Using Panel Controls.