

Small Signal Zener Diodes

Features

- Zener voltage specified at 50 μ A
- Maximum delta V_Z given from 10 μ A to 100 μ A
- Very high stability
- Low noise
- Lead (Pb)-free component
- Component in accordance to RoHS 2002/95/EC and WEEE 2002/96/EC

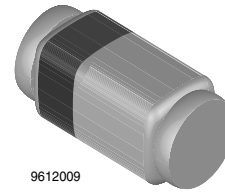

9612009

Applications

- Voltage stabilization

Packaging Codes/Options:

GS08 / 2.5 k per 7" reel 12.5 k/box

Mechanical Data

Case: QuadroMELF Glass case SOD80

Weight: approx. 34 mg

Absolute Maximum Ratings

$T_{amb} = 25\text{ }^{\circ}\text{C}$, unless otherwise specified

Parameter	Test condition	Symbol	Value	Unit
Power dissipation	$R_{thJA} \leq 300\text{ K/W}$	P_{tot}	500	mW
Z-current		I_Z	P_{tot}/V_Z	mA
Junction temperature		T_j	175	$^{\circ}\text{C}$
Storage temperature range		T_{stg}	- 65 to + 175	$^{\circ}\text{C}$

Thermal Characteristics

$T_{amb} = 25\text{ }^{\circ}\text{C}$, unless otherwise specified

Parameter	Test condition	Symbol	Value	Unit
Junction to ambient air	on PC board 50 mm x 50 mm x 1.6 mm	R_{thJA}	500	K/W

Electrical Characteristics

$T_{amb} = 25\text{ }^{\circ}\text{C}$, unless otherwise specified

Parameter	Test condition	Symbol	Min	Typ.	Max	Unit
Forward voltage	$I_F = 100\text{ mA}$	V_F			1.5	V

Electrical Characteristics

Partnumber	Zener Voltage			Max. Zener Current	Max. Voltage Change	Max. Reverse Current	Test Voltage
	V_Z at $I_Z = 50 \mu\text{A}$						
	typ ¹⁾	min	max	mA	V	μA	V
TZS4678	1.8	1.71	1.89	120	0.7	7.5	1
TZS4679	2	1.9	2.1	110	0.7	5	1
TZS4680	2.2	2.09	2.31	100	0.75	4	1
TZS4681	2.4	2.28	2.52	95	0.80	2	1
TZS4682	2.7	2.565	2.835	90	0.85	1	1
TZS4683	3	2.85	3.15	85	0.90	0.80	1
TZS4684	3.3	3.135	3.465	80	0.95	7.5	1.5
TZS4685	3.6	3.42	3.78	75	0.95	7.5	2
TZS4686	3.9	3.705	4.095	70	0.97	5	2
TZS4687	4.3	4.085	4.515	65	0.99	4	2
TZS4688	4.7	4.465	4.935	60	0.99	10	3
TZS4689	5.1	4.845	5.355	55	0.97	10	3
TZS4690	5.6	5.32	5.88	50	0.96	10	4
TZS4691	6.2	5.89	6.51	45	0.95	10	5
TZS4692	6.8	6.46	7.14	35	0.90	10	5.1
TZS4693	7.5	7.125	7.875	31.8	0.75	10	5.7
TZS4694	8.2	7.79	8.61	29	0.5	1	6.2
TZS4695	8.7	8.265	9.135	27.4	0.1	1	6.6
TZS4696	9.1	8.645	9.555	26.2	0.08	1	6.9
TZS4697	10	9.5	10.5	24.8	0.1	1	7.6
TZS4698	11	10.45	11.55	21.6	0.11	0.05	8.4
TZS4699	12	11.4	12.6	20.4	0.12	0.05	9.1
TZS4700	13	12.35	13.65	19	0.13	0.05	9.8
TZS4701	14	13.3	14.7	17.5	0.14	0.05	10.6
TZS4702	15	14.25	15.75	16.3	0.15	0.05	11.4
TZS4703	16	15.2	16.8	15.4	0.16	0.05	12.1
TZS4704	17	16.15	17.85	14.5	0.17	0.05	12.9
TZS4705	18	17.1	18.9	13.2	0.18	0.05	13.6
TZS4706	19	18.05	19.95	12.5	0.19	0.05	14.4
TZS4707	20	19	21	11.9	0.2	0.01	15.2
TZS4708	22	20.9	23.1	10.8	0.22	0.01	16.7
TZS4709	24	22.8	25.2	9.9	0.24	0.01	18.2
TZS4710	25	23.75	26.25	9.5	0.25	0.01	19
TZS4711	27	25.65	28.35	8.8	0.27	0.01	20.4
TZS4712	28	26.6	29.4	8.5	0.28	0.01	21.2
TZS4713	30	28.5	31.5	7.9	0.3	0.01	22.8
TZS4714	33	31.35	34.65	7.2	0.33	0.01	25
TZS4715	36	34.2	37.8	6.6	0.36	0.01	27.3
TZS4716	39	37.05	40.95	6.1	0.39	0.01	29.6
TZS4717	43	40.85	45.15	5.5	0.43	0.01	32.6

¹⁾ Tolerancing and voltage designation (V_Z). The type numbers shown have a standard tolerance of $\pm 5\%$ on the nominal zener voltage.

²⁾ Maximum zener current ratings (I_{ZM}). Maximum zener current ratings are based on maximum zener voltage of the individual units.

³⁾ Reverse leakage current (I_R). Reverse leakage currents are guaranteed and measured at V_R as shown on the table.

⁴⁾ Maximum voltage change (ΔV_Z). Voltage change is equal to the difference between V_Z at $100 \mu\text{A}$ and V_Z at $10 \mu\text{A}$.

Typical Characteristics

$T_{amb} = 25\text{ }^{\circ}\text{C}$, unless otherwise specified

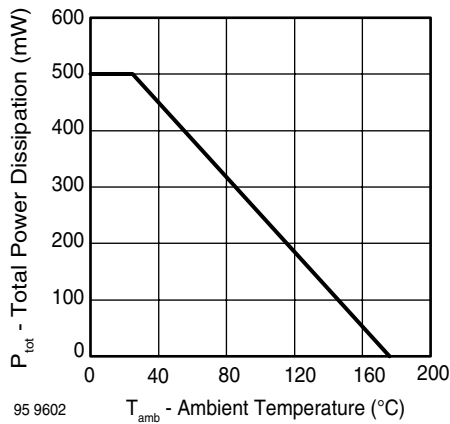

Figure 1. Total Power Dissipation vs. Ambient Temperature

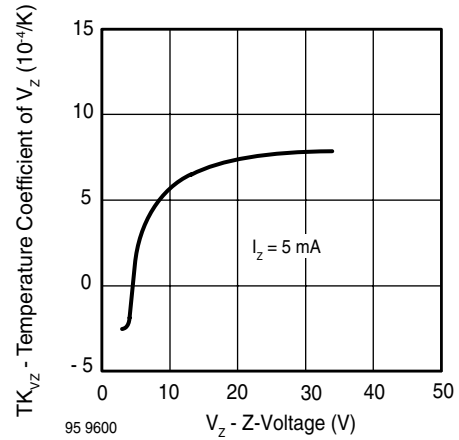

Figure 4. Temperature Coefficient of V_z vs. Z-Voltage

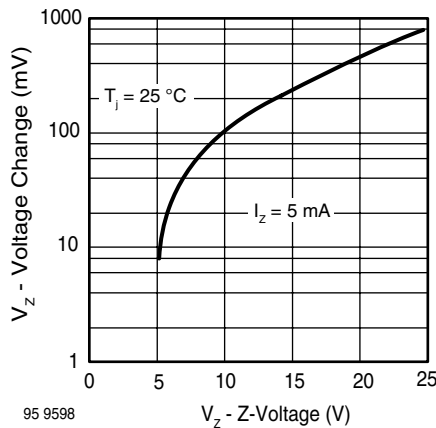

Figure 2. Typical Change of Working Voltage under Operating Conditions at $T_{amb}=25\text{ }^{\circ}\text{C}$

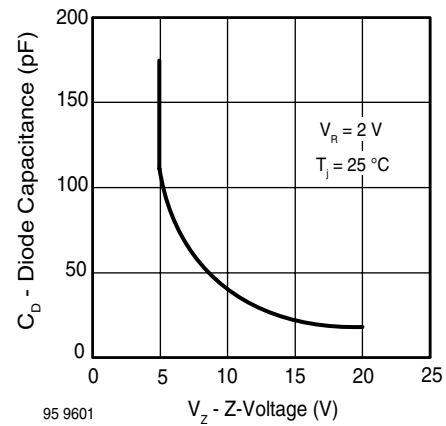

Figure 5. Diode Capacitance vs. Z-Voltage

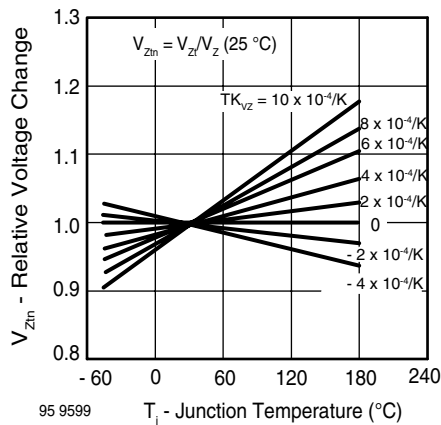

Figure 3. Typical Change of Working Voltage vs. Junction Temperature

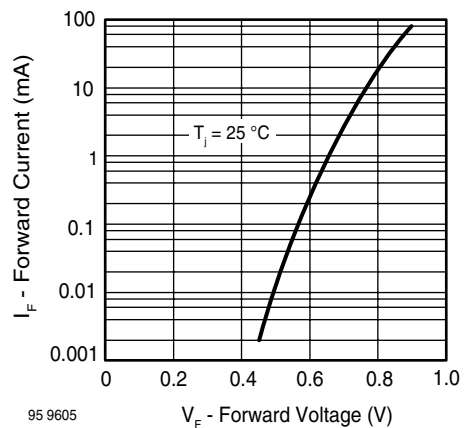

Figure 6. Forward Current vs. Forward Voltage

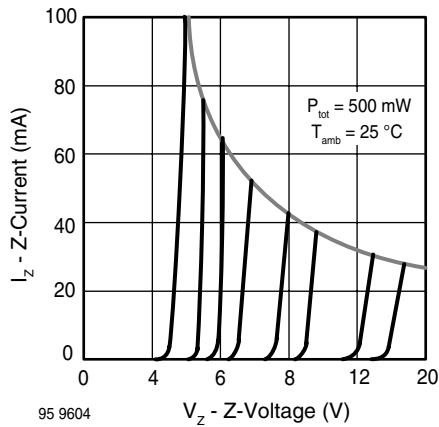

Figure 7. Z-Current vs. Z-Voltage

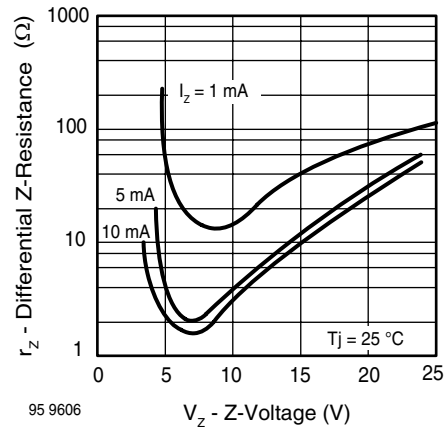

Figure 9. Differential Z-Resistance vs. Z-Voltage

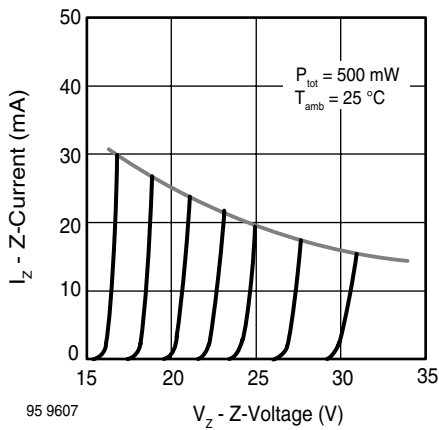

Figure 8. Z-Current vs. Z-Voltage

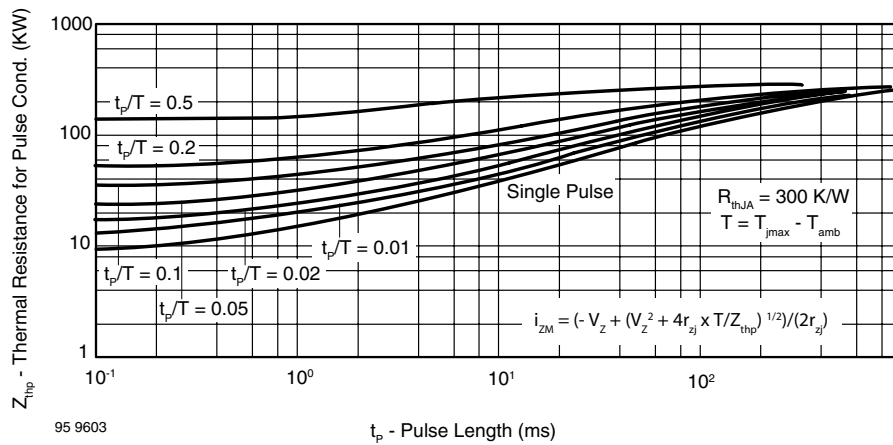
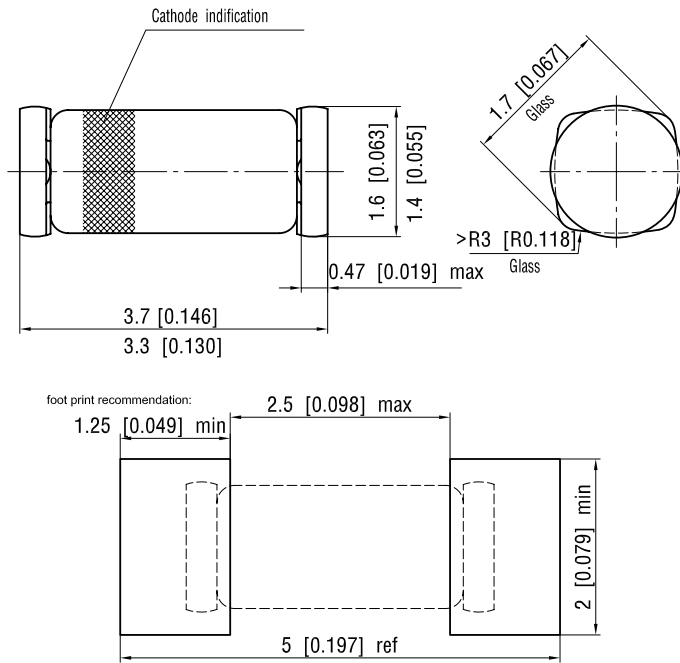

Figure 10. Thermal Response

Package Dimensions in mm (Inches)



Document no.: 6.560-5006.01-4
 Rev. 10 - Date: 30.August.2004

12071

Ozone Depleting Substances Policy Statement

It is the policy of Vishay Semiconductor GmbH to

1. Meet all present and future national and international statutory requirements.
2. Regularly and continuously improve the performance of our products, processes, distribution and operating systems with respect to their impact on the health and safety of our employees and the public, as well as their impact on the environment.

It is particular concern to control or eliminate releases of those substances into the atmosphere which are known as ozone depleting substances (ODSs).

The Montreal Protocol (1987) and its London Amendments (1990) intend to severely restrict the use of ODSs and forbid their use within the next ten years. Various national and international initiatives are pressing for an earlier ban on these substances.

Vishay Semiconductor GmbH has been able to use its policy of continuous improvements to eliminate the use of ODSs listed in the following documents.

1. Annex A, B and list of transitional substances of the Montreal Protocol and the London Amendments respectively
2. Class I and II ozone depleting substances in the Clean Air Act Amendments of 1990 by the Environmental Protection Agency (EPA) in the USA
3. Council Decision 88/540/EEC and 91/690/EEC Annex A, B and C (transitional substances) respectively.

Vishay Semiconductor GmbH can certify that our semiconductors are not manufactured with ozone depleting substances and do not contain such substances.

We reserve the right to make changes to improve technical design
and may do so without further notice.

Parameters can vary in different applications. All operating parameters must be validated for each customer application by the customer. Should the buyer use Vishay Semiconductors products for any unintended or unauthorized application, the buyer shall indemnify Vishay Semiconductors against all claims, costs, damages, and expenses, arising out of, directly or indirectly, any claim of personal damage, injury or death associated with such unintended or unauthorized use.

Vishay Semiconductor GmbH, P.O.B. 3535, D-74025 Heilbronn, Germany



Disclaimer

All product specifications and data are subject to change without notice.

Vishay Intertechnology, Inc., its affiliates, agents, and employees, and all persons acting on its or their behalf (collectively, "Vishay"), disclaim any and all liability for any errors, inaccuracies or incompleteness contained herein or in any other disclosure relating to any product.

Vishay disclaims any and all liability arising out of the use or application of any product described herein or of any information provided herein to the maximum extent permitted by law. The product specifications do not expand or otherwise modify Vishay's terms and conditions of purchase, including but not limited to the warranty expressed therein, which apply to these products.

No license, express or implied, by estoppel or otherwise, to any intellectual property rights is granted by this document or by any conduct of Vishay.

The products shown herein are not designed for use in medical, life-saving, or life-sustaining applications unless otherwise expressly indicated. Customers using or selling Vishay products not expressly indicated for use in such applications do so entirely at their own risk and agree to fully indemnify Vishay for any damages arising or resulting from such use or sale. Please contact authorized Vishay personnel to obtain written terms and conditions regarding products designed for such applications.

Product names and markings noted herein may be trademarks of their respective owners.