

Shoulder 好达

SHOULDER ELECTRONICS LIMITED

SAW Components Data Sheet

PRODUCT 产品: SAW FILTER

MODEL NO 型号: HDF1120A SMD-7

PREPARED 编制:

CHECKED 审核:

APPROVED 批准:

DATE 日期: 2007-01-25

1. SCOPE

This specification shall cover the characteristics of SAW filter With F1120AS7 used digital television

2. ELECTRICAL SPECIFICATION

Dc voltage VDC>	0V
Operation temperature	-40°C~+85°C
Storage temperature	-40°C~+85°C
RF Power dissipation	0 dBm(source impedance 200Ω)

Electronic Characteristics

2-1. Typical frequency response

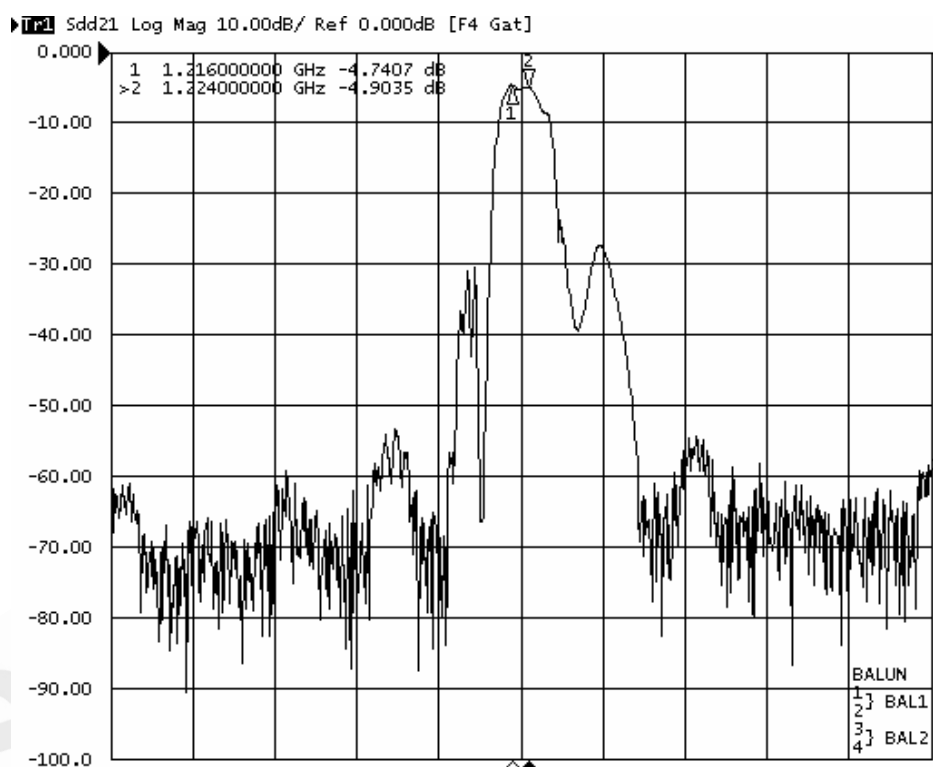

2-2. Electrical characteristics

Par number	HDF1120AS7	Unit
Norminal center frequency(Fo)	1120	MHz
Insertion loss:		
500.00~Fc-85.00MHz	50.0 min.	dB
Fc-76.00~Fc-68.00MHz	46.0 min.	
Fc-44.00MHz	50.0 min	
Fc-36.00MHz	50.0 min	
Fc±4.00MHz	6.80 max.	
Fc+70.00~2000.00MHz	50.0 min.	
Ripple (with Fo ±4.0MHz)	1.5 max.	dB
Input/Output Impedance	200	ohm

3. TEST CIRCUIT

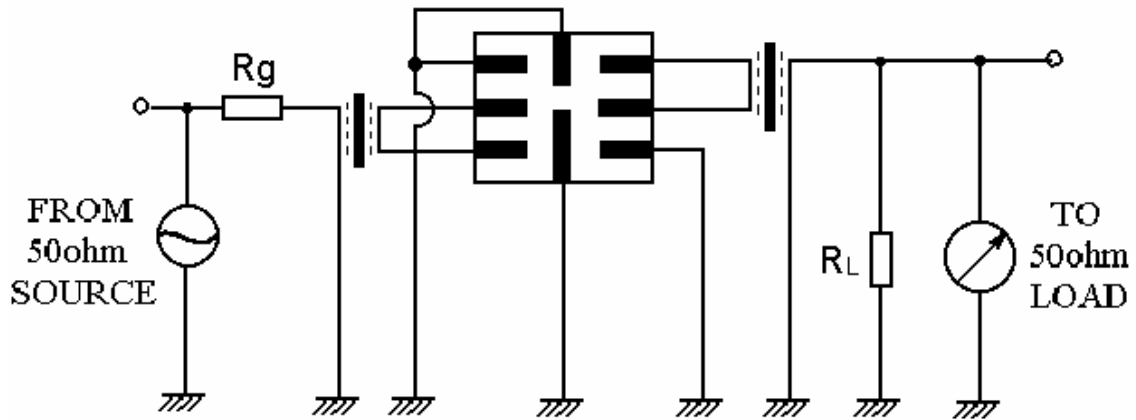

4. DIMENSION

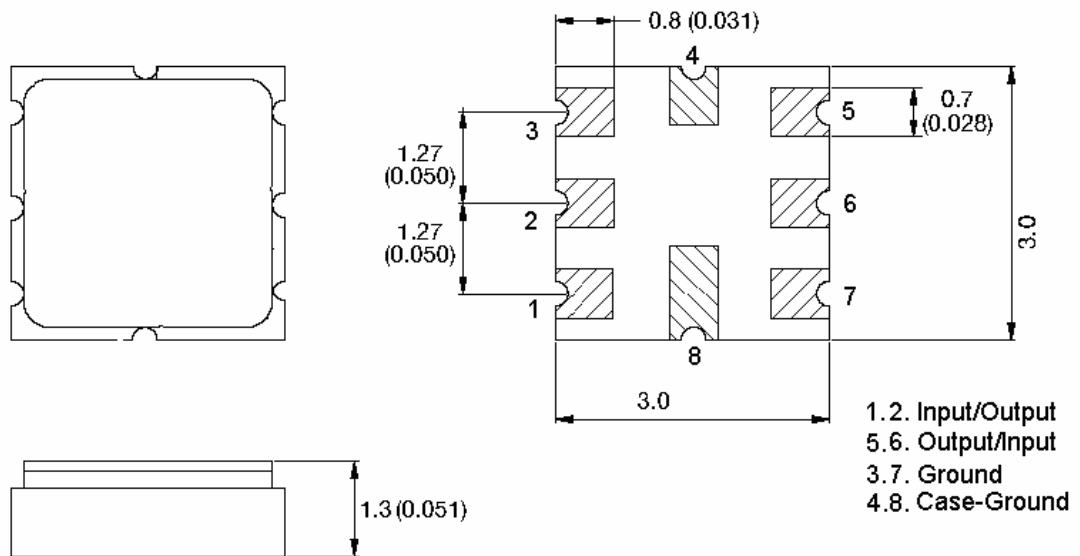

5. ENVIRONMENTAL CHARACTERISTICS

5-1 Temperature cycling

Subject the device to a low temperature of -45°C for 30 minutes. Following by a high temperature of $+25^{\circ}\text{C}$ for 5 Minutes and a higher temperature of $+85^{\circ}\text{C}$ for 30 Minutes. Then release the device into the room conditions for 1 to 2 hours prior to the measurement. It shall meet the specifications in table 1.

5-2 Resistance to solder heat

Submerge the device terminals into the solder bath at $260^{\circ}\text{C} \pm 5^{\circ}\text{C}$ for 10 ± 1 sec. Then release the device into the room conditions for 4 hours. It shall meet the specifications in table 1.

5-3 Solderability

Submerge the device terminals into the solder bath at $245^{\circ}\text{C} \pm 5^{\circ}\text{C}$ for 5s, More than 95% area of the soldering pad must be covered with new solder. It shall meet the specifications in table 1.

5-4 Mechanical shock

Drop the device randomly onto the concrete floor from the height of 1 m 3 times. the filter shall fulfill the specifications in table 1.

5-5 Vibration

Subject the device to the vibration for 2 hour each in x,y and z axes with the amplitude of 1.5 mm at 10 to 55 hz. The filter shall fulfill the specifications in table 1.

6. REMARK

6.1 Static voltage

Static voltage between signal load & ground may cause deterioration & destruction of the component. Please avoid static voltage.

6.2 Ultrasonic cleaning

Ultrasonic vibration may cause deterioration & destruction of the component. Please avoid ultrasonic cleaning

6.3 Soldering

Only leads of component may be soldered. Please avoid soldering another part of component.

7. Packing

7.1 Dimensions

(1) Carrier Tape: Figure 1

(2) Reel: Figure 2

(3) The product shall be packed properly not to be damaged during transportation and storage.

7.2 Reeling Quantity

1000 pcs/reel 7"

3000 pcs/reel 13"

7.3 Taping Structure

(1) The tape shall be wound around the reel in the direction shown below.

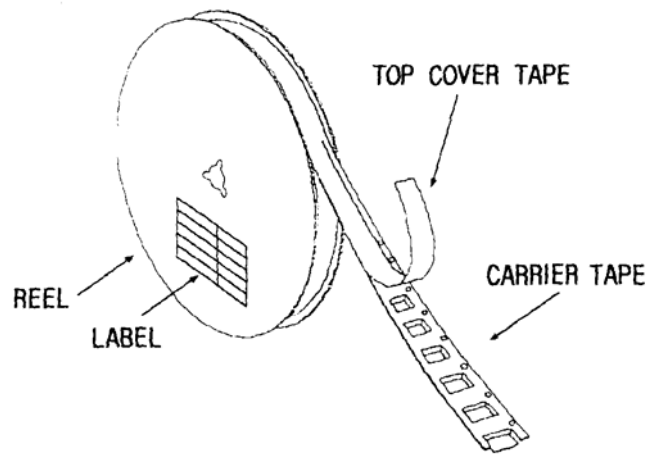

(2) Label

Device Name	
User Product Name	
Quantity	
Lot No.	

(3) Leader part and vacant position specifications.

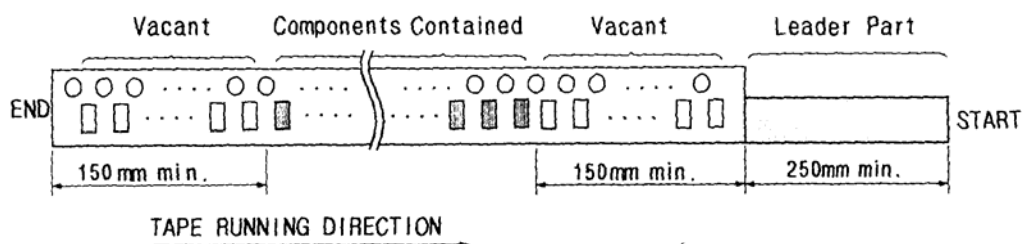

8. TAPE SPECIFICATIONS

8.1 Tensile Strength of Carrier Tape: 4.4N/mm width

8.2 Top Cover Tape Adhesion (See the below figure)

- (1) pull off angle: 0~15°
- (2) speed: 300mm/min.
- (3) force: 20~70g

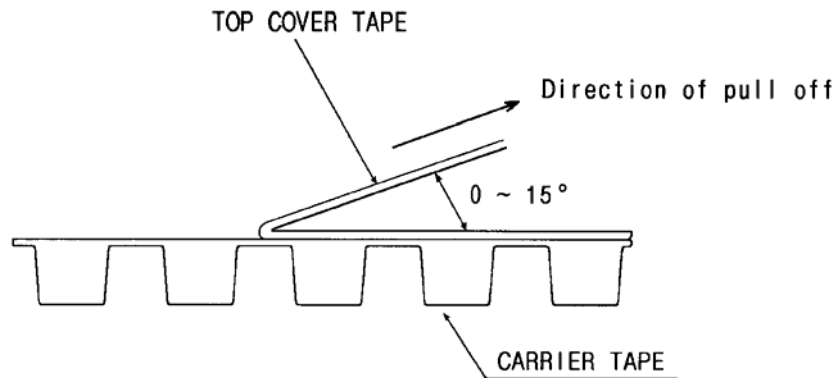

[Figure 1] Carrier Tape Dimensions

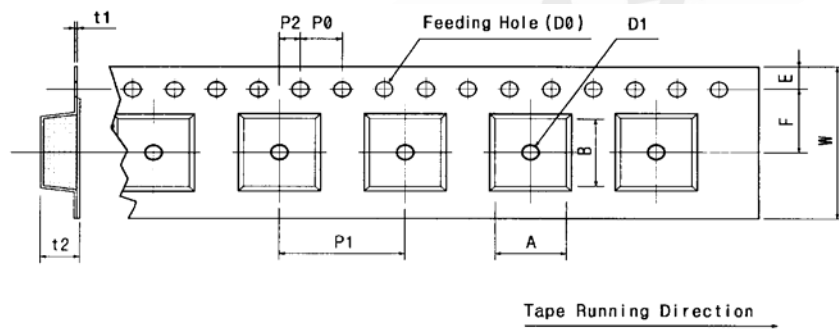

[Unit:mm]

W	F	E	P0	P1	P2	D0	D1	t1	t2	A	B
12.00	5.50	1.75	4.00	4.00	2.00	Ø1.50	Ø1.5	0.31	1.30	3.4	3.4
±0.30	±0.10	±0.10	±0.10	±0.10	±0.10		±0.25	±0.05	±0.10	MAX.	MAX.

[Figure 2]

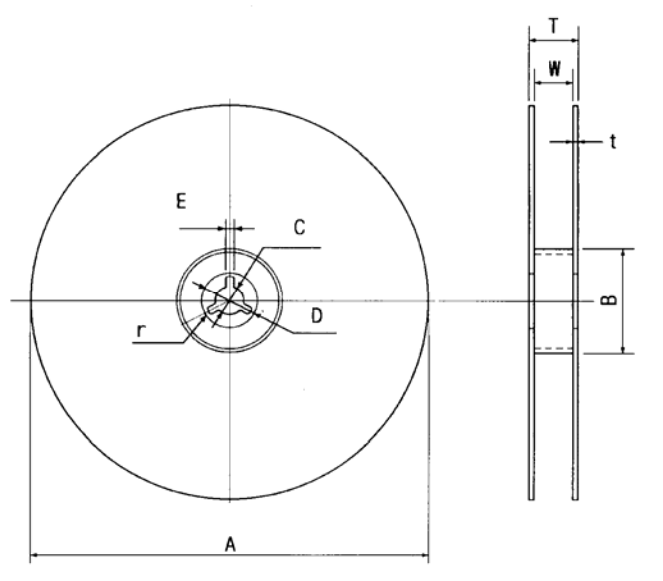

[Unit:mm]

A	B	C	D	E	W	t	r
Ø330	Ø100	Ø13	Ø21	2	13	3	1.0
±1.0	±0.5	±0.5	±0.8	±0.5	±0.3	max.	max.