



## DESCRIPTION

The PT8921 is a cost-efficient single chip for audio mini-combo play-station application. The chip integrated the USB2.0 FS host controller, SD/MMC host controller, Sigma-Delta Audio-DAC and WAV/MP3/WMA/AAC Audio-Decoder in one chip. Only few external components needed in application circuits makes it suite for the audio play-station system with USB2.0 FS host, SD/MMC host and i-Pod audio control interfaces.

The I/O interfaces are totally following the USB2.0 FS host class interface specification and SD/MMC card specification. The stand alone audio play-station and no special driver software need to install on this system by user in the recent market. The PT8921 is a truly plug and play audio play-station controller with USB2.0 FS host and SD/MMC host interfaces. There are some extended functions for the different audio sources and applications. The embedded 8 pins provide the player function key and other adjustment feature. The 5 GPIO-pins support the other control function for customer application.

## APPLICATIONS

- Portable Audio Play-Station
- Car Audio Combo-Station
- Home Audio Play-Station

## FEATURES

- Built-in USB 2.0 FS Mini-Host interface.
- Compliant with USB Mass-storage class specification.
- Built-in SD/MMC Host interface.
- Compliant with SD/SDIO Card specification Version 2.0.
- Compliant with MMC Card specification Version 4.2.
- Support FAT12, FAT16 and FAT32 file system.
- Built-in 8051 base MCU with 8K ROM.
- Support ISP (In-System-Programmable) Interface for external program Flash-ROM.
- Built-in WAV/MP3 WMA/AAC Format Audio-Decoder.
- Support MPEG1/2/2.5 layer III audio decoding.
- Built-In Flat/Pop/Jazz/Classic/Rock processing function.
- Built-In Digital Volume control function
- Built-in SNR=85dB (A-Weighted) Sigma-Delta DAC, PWM Output.
- Built-in IIC Master/Slave Control Interface.
- Built-in UART Interface to communicate with i-Pod.
- Built-in external IIS input for optional audio input sources, and support one IIS output connecting an external advanced audio controller or stand-alone sigma-delta DAC controller.
- Packages: 100 Pins LQFP

## BLOCK DIAGRAM

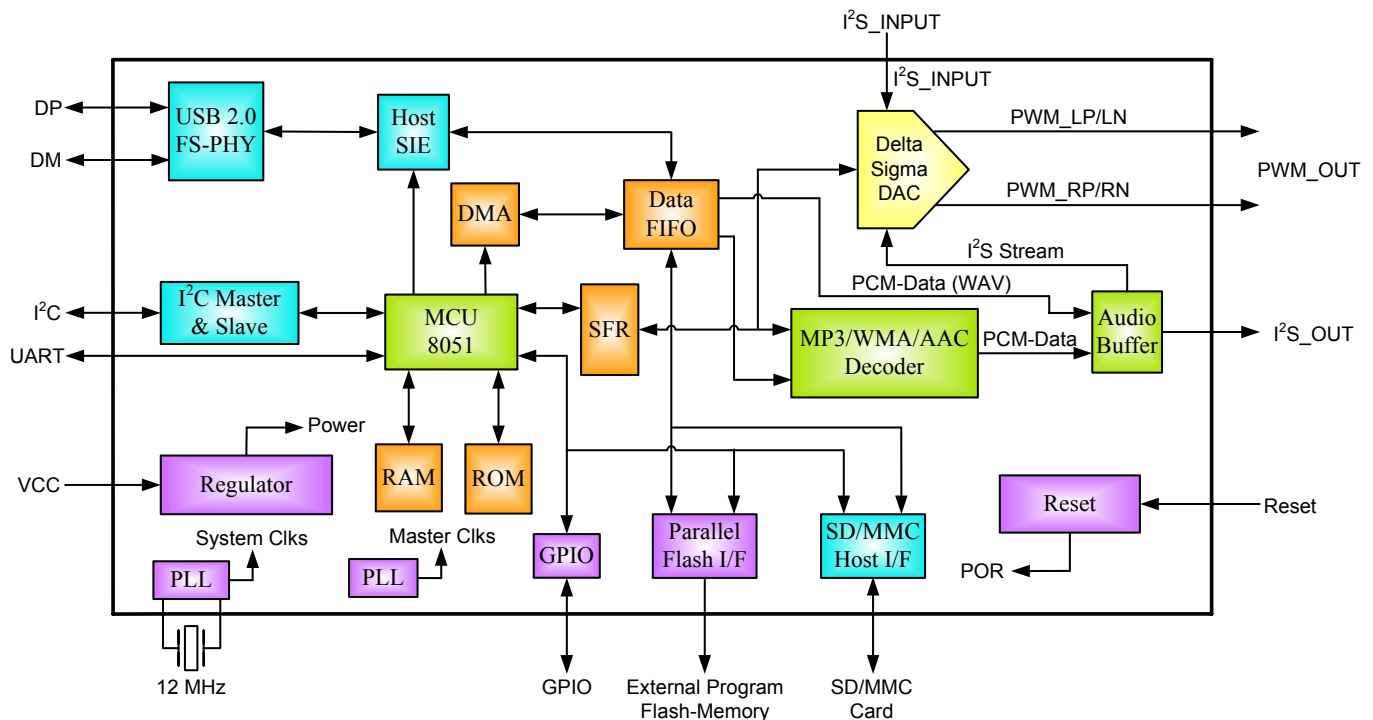

# SYSTEM APPLICATION DIAGRAM

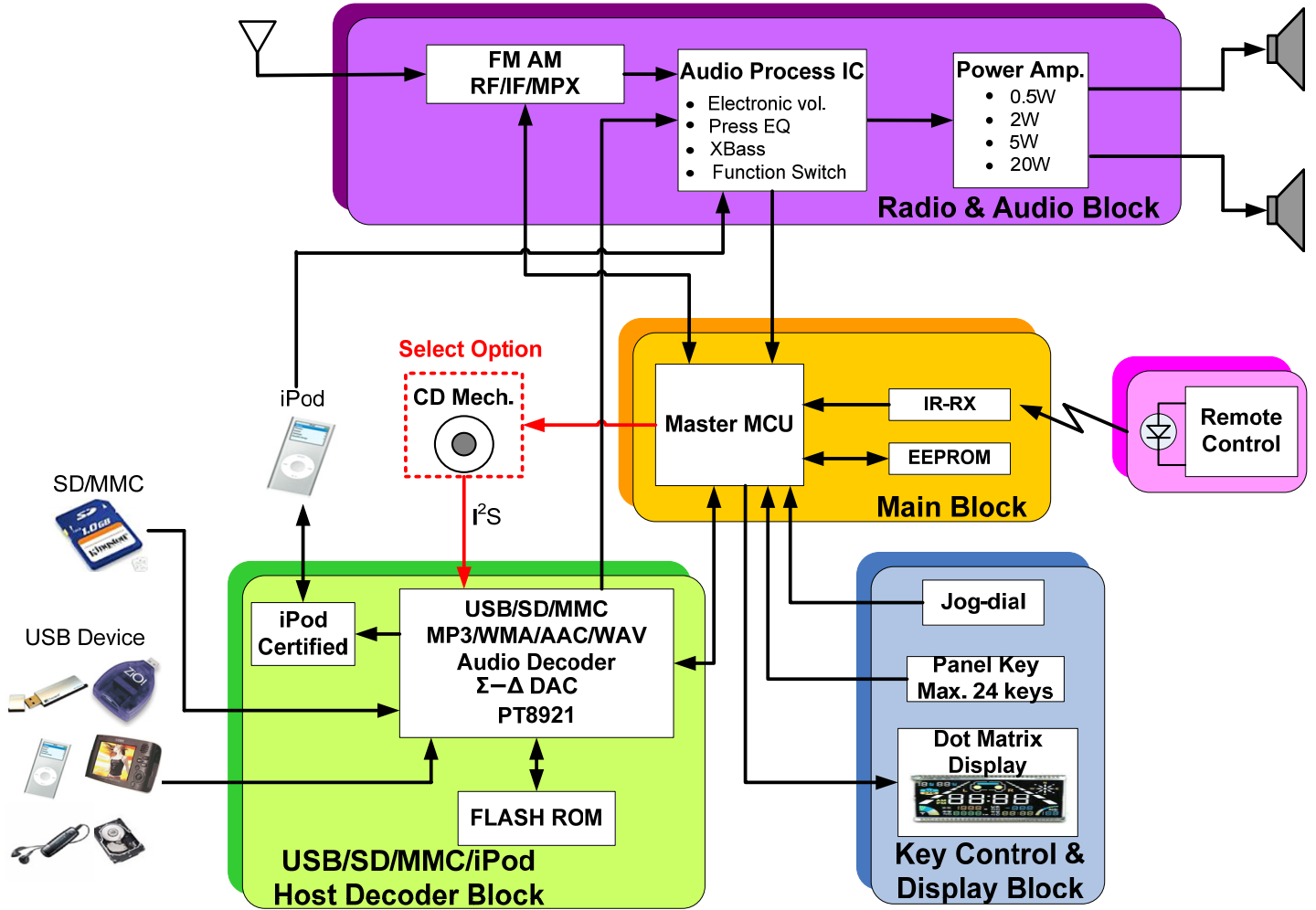



## ORDER INFORMATION

Valid Part Number	Package Type	Top Code
PT8921-LQ	100-PIN LQFP	PT8921-LQ

## PIN CONFIGURATION

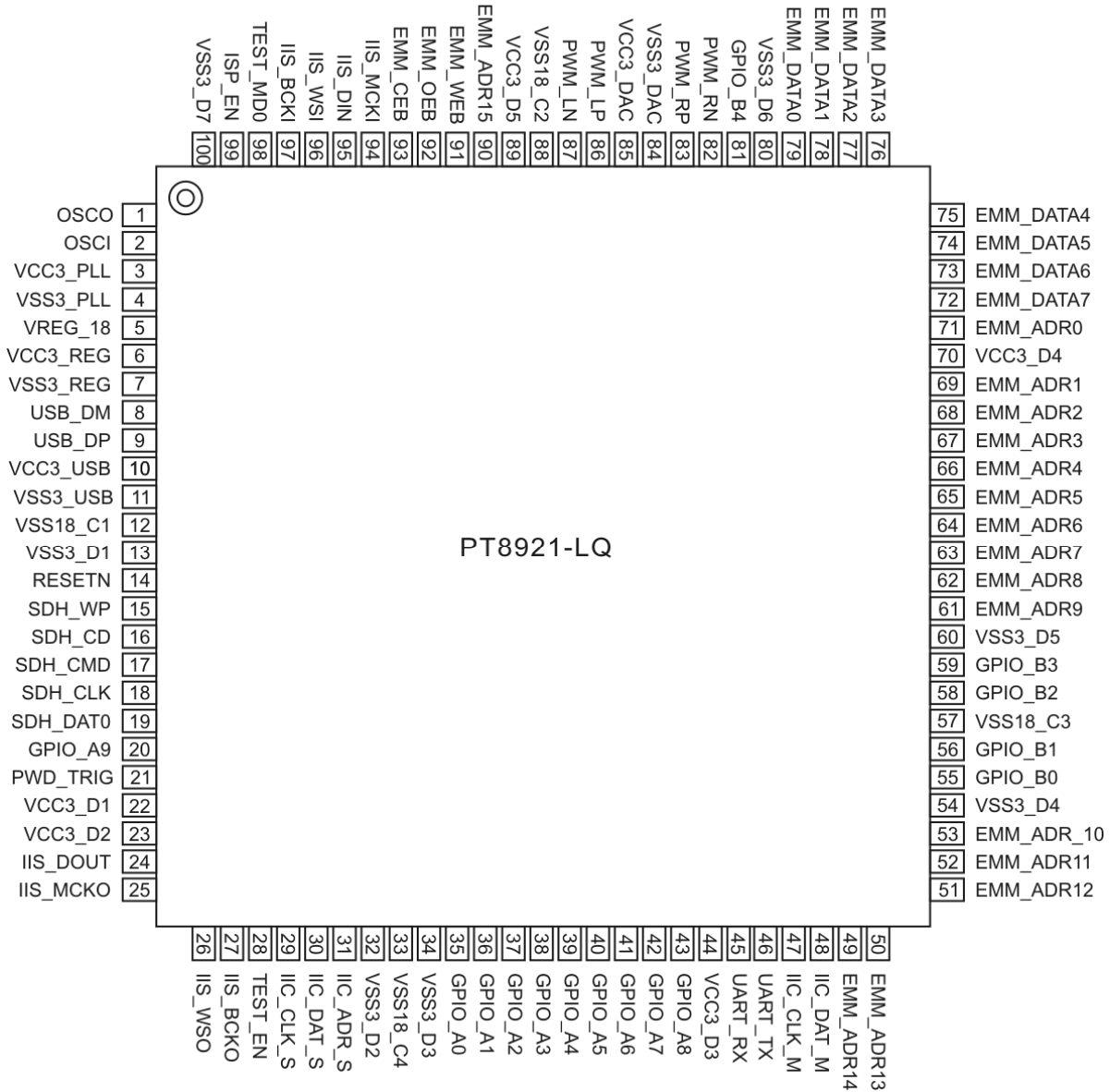

## **IMPORTANT NOTICE**

Princeton Technology Corporation (PTC) reserves the right to make corrections, modifications, enhancements, improvements, and other changes to its products and to discontinue any product without notice at any time.

PTC cannot assume responsibility for use of any circuitry other than circuitry entirely embodied in a PTC product. No circuit patent licenses are implied.

Princeton Technology Corp.  
2F, 233-1, Baociao Road,  
Sindian, Taipei 23145, Taiwan  
Tel: 886-2-66296288  
Fax: 886-2-29174598  
<http://www.princeton.com.tw>