

PLEASE CHECK WWW.MOLEX.COM FOR LATEST PART INFORMATION

Part Number: **0500128000**
Status: **Active**
Description: 2.00mm (.079") Pitch Crimp Terminal, Reel, for 51006 Housing

Documents:

3D Model [Product Specification PS-51005-001 \(PDF\)](#)
Drawing (PDF) [RoHS Certificate of Compliance \(PDF\)](#)

General

Product Family Crimp Terminals
Series 50012
Crimp Quality Equipment Yes
Product Name N/A

Physical

Gender Male
Material - Metal Phosphor Bronze
Material - Plating Mating Tin
Material - Plating Termination Tin
Packaging Type Reel
Plating min: Mating (µin) 36
Plating min: Mating (µm) 0.90
Plating min: Termination (µin) 36
Plating min: Termination (µm) 0.90
Termination Interface: Style Crimp or Compression
Wire Insulation Diameter 0.90-1.15mm (.035-.045")
Wire Size AWG 24, 26, 28
Wire Size mm² N/A

Electrical

Current - Maximum per Contact 2A
Voltage - Maximum 125V

Material Info

Reference - Drawing Numbers

Product Specification PS-51005-001
Sales Drawing SD-50012-001

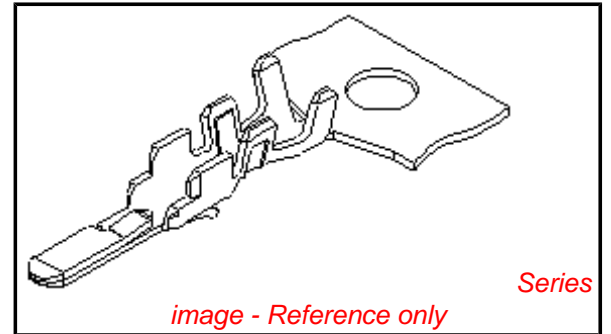

EU RoHS

**ELV and RoHS
Compliant**
**REACH SVHC
Contains SVHC: No**
**Halogen-Free
Status**
Halogen-Free

China RoHS



**Need more information on product
environmental compliance?**

Email productcompliance@molex.com
For a multiple part number RoHS Certificate of
Compliance, [click here](#)

Please visit the [Contact Us](#) section for any
non-product compliance questions.

Search Parts in this Series

50012Series

Mates With

50013

Use With

51006

Application Tooling | FAQ

*Tooling specifications and manuals are
found by selecting the products below.
Crimp Height Specifications are then
contained in the Application Tooling
Specification document.*

Global

Description	Product #
Hand Crimp Tool, UL Approved	UL0638117800
T2 Terminator Die	0638515000
FineAdjust™ Applicator	0638615000

Japan

Description	Product #
-------------	-----------

Applicator for M21 1A 0570453000
Bench Press, 24-28
AWG, for 50012
Crimp Terminal

This document was generated on 04/15/2010

PLEASE CHECK WWW.MOLEX.COM FOR LATEST PART INFORMATION

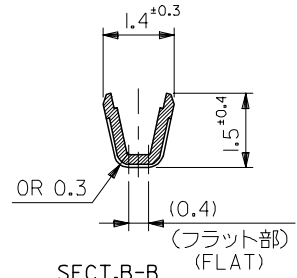
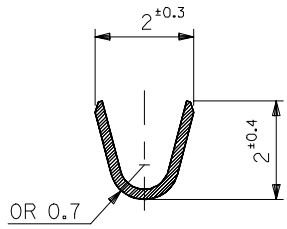
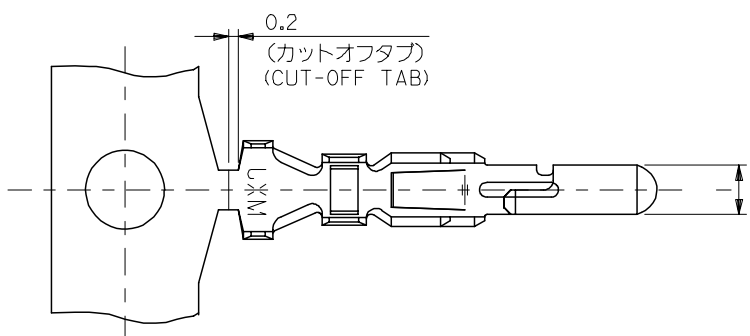

SECT.A-A

SECT.B-B

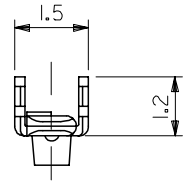
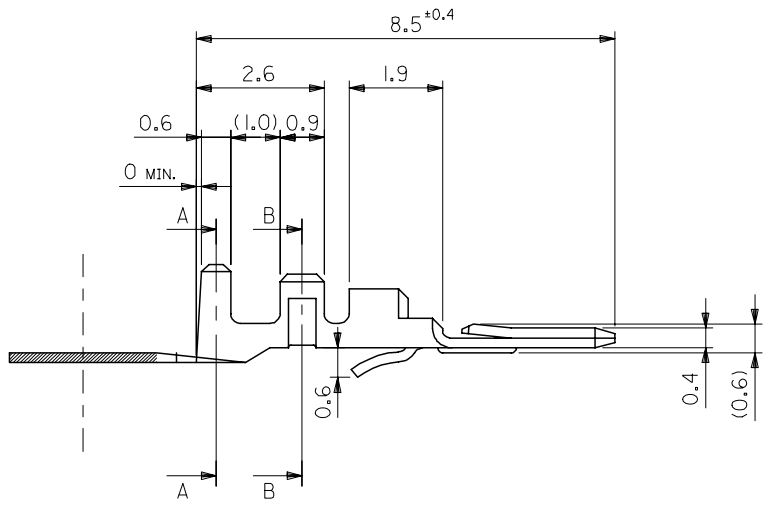

注記
NOTES

1. 適合ハウジング : 51006
APPLICABLE HOUSING : 51006
2. 嵌合相手 : 50013
MATE WITH : 50013
3. ELV 及び RoHS適合品
ELV AND RoHS COMPLIANT.

材料 MATERIAL	リン青銅 錫メッキ (t=0.2) PHOS. BRO. PRE-TINNED (t=0.2)
仕上げ FINISH	—
適用電線範囲 WIRE RANGE	AWG#24 ~ #28
被覆外径 INS. RANGE	φ0.9 - φ1.15

REVISED	EC NO: J2008-0075	2007/07/16
DRWN: NABEJ	CHKD: THARUYAMA	2007/07/17
APPR: NUKITA		2007/07/17
DESCRIPTION		
REV	C	

GENERAL TOLERANCES (UNLESS SPECIFIED)	
10 UNDER	±0.2
10 OVER 30 UNDER	±0.25
30 OVER	±0.3
ANGULAR	±3 °
DRAFT WHERE APPLICABLE MUST REMAIN WITHIN DIMENSIONS	

DIMENSION STYLE MM ONLY	
DRAWN BY	DATE
T. YASUI	'95/08/21
CHECKED BY	DATE
H. HIRAMOTO	'95/08/22
APPROVED BY	DATE
M. FUKUSHIMA	'95/08/22
MATERIAL NO.	
SEE TABLE	
SIZE	A3

SCALE	10:1
DESIGN UNITS	METRIC
THIRD ANGLE PROJECTION	
TITLE	
2.0 WIRE TO WIRE CONN. CRIMP PIN	
MOLEX INCORPORATED	
DOCUMENT NO.	SD-50012-001
SHEET NO.	1 OF 1

50012-8*00	MODEL NO.
------------	-----------

50012-8100	バラ状 LOOSE
50012-8000	連鎖状 CHAIN
MATERIAL NO.	端子形状 FORM