



DESCRIPTION

PT2308P is a 2 channel Class AB stereo speaker driver utilizing CMOS technology designed by AB push-pull, the original sound will be low distortion amplify and low consumption. The power of PT2308P will be reach 300mW on THD=10% and deliver 8Ω load.

APPLICATIONS

- Walkman
- Portable audio
- HI-FI audio system
- CD-ROM

FEATURES

- Wild operating temperature large
- Excellent Power Signal-to-Noise Repel Rate (PSRR)
- Low static state current consumption
- Output power (THD=10%)
 - Load is 16Ω/190mW
 - Load is 8Ω/300mW
- Low harmonics distortion (THD=0.03%)
- Large output amplitude

BLOCK DIAGRAM

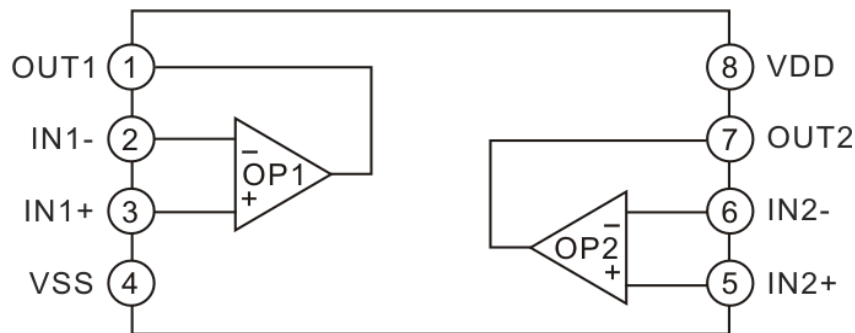

APPLICATION CIRCUIT

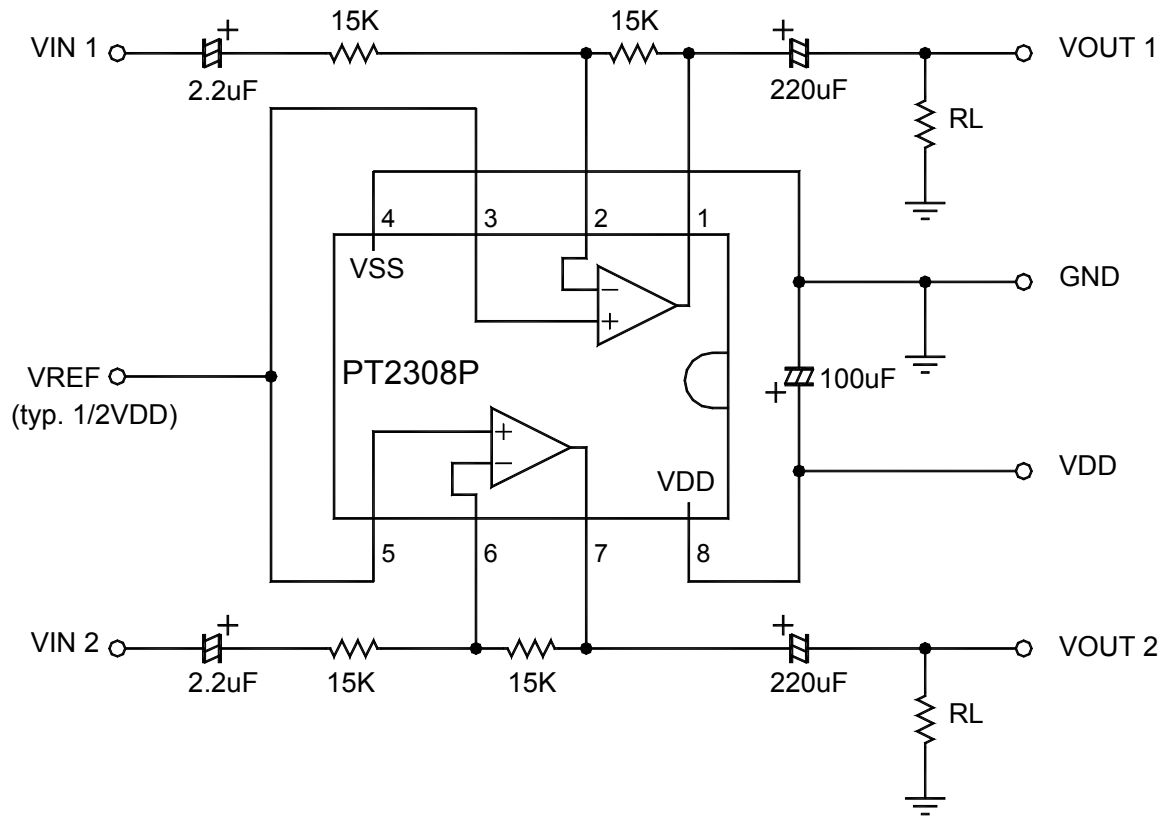

ORDER INFORMATION

Valid Part Number	Package Type	Top Code
PT2308P-S	8 Pins, SOP, 150mil	PT2308P-S

PIN CONFIGURATION

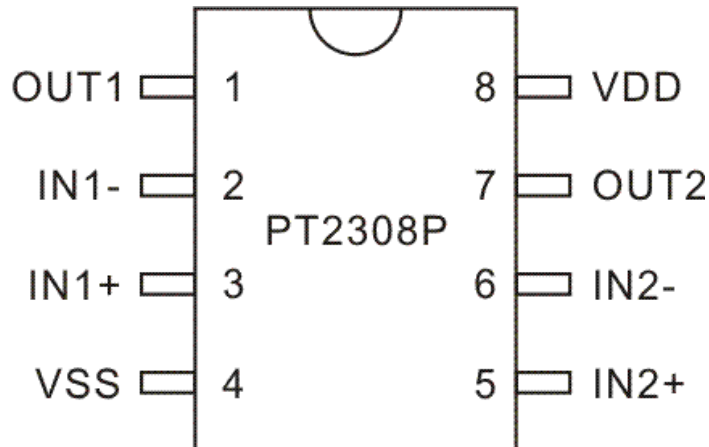

PIN DESCRIPTION

Pin Name	I/O	Description	Pin No.
OUT1	O	Output pin 1	1
IN1-	I	Inverting input pin 1	2
IN1+	I	Non-inverting input pin 1	3
VSS	-	Negative power supply	4
IN2+	I	Non-inverting input pin 2	5
IN2-	I	Inverting input pin 2	6
OUT2	O	Output pin 2	7
VDD	-	Positive power supply	8

BASIC APPLICATION DESCRIPTION

PT2308P is a low power amplifier which operates with a 5V input voltage, it can be used to drive regular earphones or low power speakers with a load resistance of 8ohm or higher. The operation mechanics is much like the typical OPAMP. (The picture below shows the basic application circuit of PT2308P as an inverted amplifier).

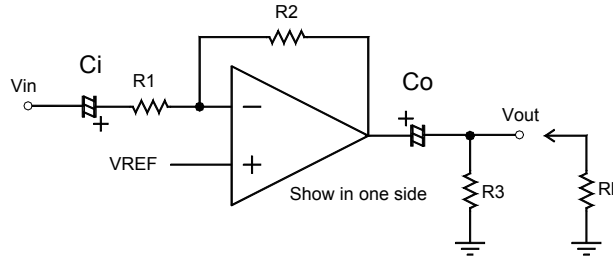

PT2308P Typical Application Circuit

1. Gain Settings

The inverted amplifier's amplification is equal to the ratio between R2 and R1 ($A_v = -(R2/R1)$). Please take note that the maximum supply voltage for the PT2308P is 5V, voltage gain setting should depend on the input level amplitude; too much voltage gain may increase the chance of causing clipping at the output.

2. VREF

Because the PT2308P operates with a single power source, to ensure the best output performance, the suggested value for VREF is 1/2 VDD.

3. Input Coupling Capacitor Ci

In typical applications, this input coupling capacitor transfers signals between the input and PT2308P, it allows block DC bias of the PT2308P flowing into input signal, and thus the user must be aware of the voltage tolerance and the polarity of this Cap.

Referring to the diagram above, Ci and R1 forms a 1st order high-pass filter; the lower-cutoff frequency is determined by the equation:

$$f_{c(\text{highpass})} = 1/2\pi R1 C_i$$

The diagram below shows the frequency response when: $C_i = 10\mu\text{F}/1\mu\text{F}/0.47\mu\text{F}/0.22\mu\text{F}/0.1\mu\text{F}$

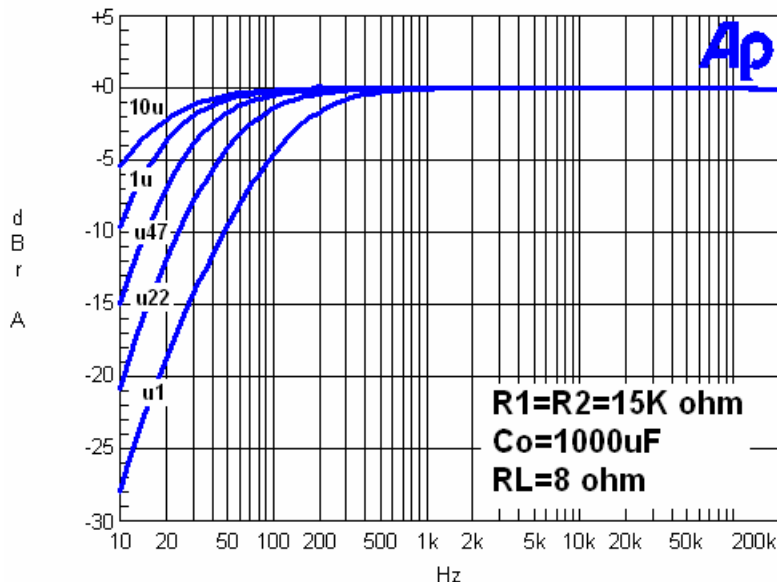

4. Output Coupling Capacitor Co

Single power single-ended (SE) configuration generates a DC bias at the output of the amplifier; a coupling capacitor must be placed at the output to block the DC bias from being sent to the load and connect a RL at the signal output terminal. The low cut-off frequency may be needs to adjust to correspond to different load (speaker or earphone) specifications. Similar to the input coupling capacitor, the output coupling capacitor and impedance of the load form a 1st order high-pass filter, the low cut-off frequency is determined by the equation:

$$f_{c(\text{highpass})} = 1/2\pi R_L C_o$$

The diagram below shows the frequency response when: Co=1000μF/470μF/220μF/100μF.

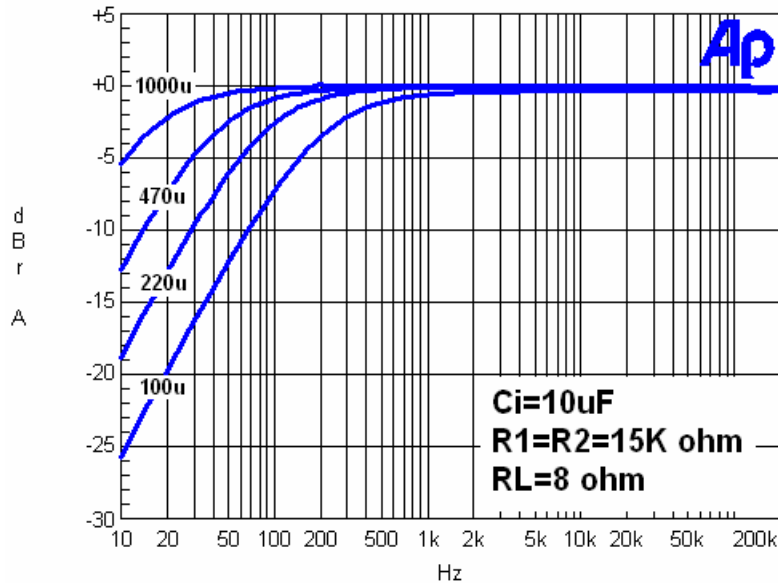

5. Discharging Resistor (R3)

When the PT2308P is powered ON, the output coupling capacitor Co will start charging. When there is no load connected at Vout, there will be a DC voltage present. At this time, if a load is suddenly connected (usually earphone or speaker for general applications), the charged Co will then discharge through Vout to the load, causing a very loud popping sound, thus, it is recommended to connect a R3 to regulate the discharge of Co.

The time it takes to discharge is $T = C_o R_3$.

The recommended resistance value for R3 is between 1KΩ ~ 10KΩ, to prevent loading effect from the amplifier. If the load (ex. Speaker) is permanently connected then R3 can be neglected.

ABSOLUTE MAXIMUM RATING

Parameter	Symbol	Rating	Unit
Supply voltage	V_{DD}	8	V
Operating temperature	T_{opr}	-40~+85	°C
Storage temperature	T_{stg}	-65~+150	°C

ELECTRONICAL CHARACTERISTICS

(Unless otherwise specified, $V_{DD}=5V$, $V_{SS}=0V$, $T_a=25^{\circ}C$, $f_{in}=1KHz$, $R_L=8\Omega$)

Parameter	Symbol	Condition	Min.	Typ.	Max.	Unit
Supply voltage	V_{DD}		2.7	5	5.5	V
Supply current	I_{DD}	No Load	-	3	4	mA
Input offset voltage	$V_{I(OS)}$		-	5	50	mV
Total harmonic distortion	THD+N	PO=200mW, $R_L=8\Omega$, F=1KHZ	-	0.04	0.1	%
		PO=120mW, $R_L=16\Omega$, F=1KHZ	-	0.03	0.06	%
Maximum output power	PO	THD=0.2%, f=1KHz, $R_L=8\Omega$	200	250	-	mW
		THD=0.2%, f=1KHz, $R_L=16\Omega$	100	130	-	mW
		THD=10%, f=1KHz, $R_L=8\Omega$	250	300	-	mW
		THD=10%, f=1KHz, $R_L=16\Omega$	160	190	-	mW
Output noise	VN		-	20	50	μV
VDD=3V						
Supply current	I_{DD}	No Load	-	2	3	mA
Input offset voltage	$V_{I(OS)}$		-	5	50	mV
Total harmonic distortion	THD+N	PO=50mW, $R_L=8\Omega$, F=1KHZ	-	0.02	0.05	%
		PO=40mW, $R_L=16\Omega$, F=1KHZ	-	0.02	0.05	%
Maximum output power	PO	THD=0.2%, f=1KHz, $R_L=8\Omega$	60	80	-	mW
		THD=0.2%, f=1KHz, $R_L=16\Omega$	40	50	-	mW
		THD=10%, f=1KHz, $R_L=8\Omega$	70	100	-	mW
		THD=10%, f=1KHz, $R_L=16\Omega$	55	70	-	mW
Output noise	VN		-	20	50	μV

PACKAGE INFORMATION

8 PINS, SOP, 150MIL

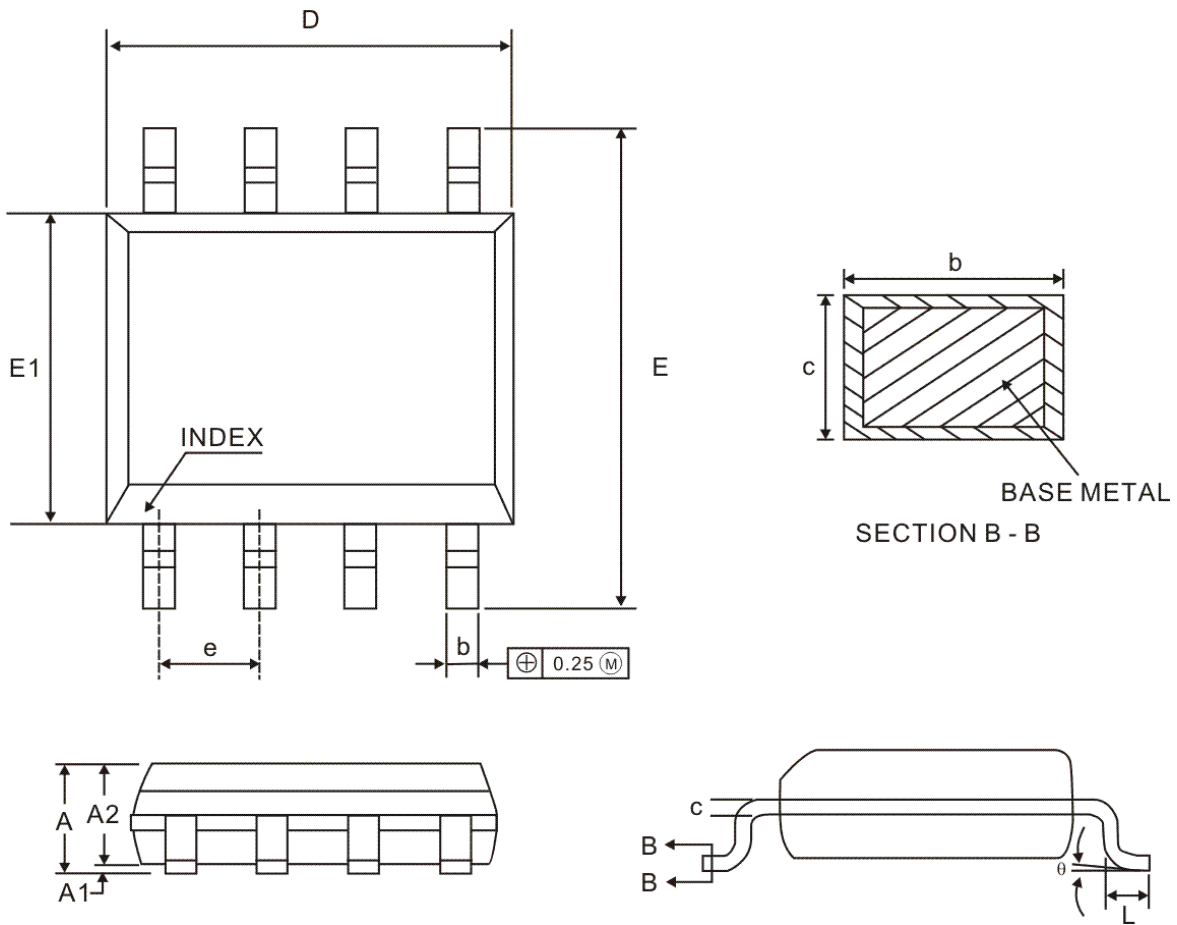

Symbol	Dimensions(MM)		
	Min.	Nom.	Max.
A	1.35	1.60	1.77
A1	0.08	0.15	0.28
A2	1.20	1.40	1.65
b	0.33	-	0.51
c	0.17	-	0.26
e	1.27 BSC		
D	4.70	4.90	5.10
E	5.80	6.00	6.20
E1	3.70	3.90	4.10
L	0.38	0.60	1.27
θ	0°	-	8°

Note: Refer to JEDEC MS-012 AA

IMPORTANT NOTICE

Princeton Technology Corporation (PTC) reserves the right to make corrections, modifications, enhancements, improvements, and other changes to its products and to discontinue any product without notice at any time.

PTC cannot assume responsibility for use of any circuitry other than circuitry entirely embodied in a PTC product. No circuit patent licenses are implied.

Princeton Technology Corp.
2F, 233-1, Baociao Road,
Sindian, Taipei 23145, Taiwan
Tel: 886-2-66296288
Fax: 886-2-29174598
<http://www.princeton.com.tw>