

Datasheet

10 Gbps 10 km Single-Mode SFP+ Transceiver

SFP-10GD-LR



Features

- Hot-pluggable SFP+ footprint
- Supports 9.95 to 10.52 Gbps bit rates
- Power dissipation < 1W
- RoHS-6 compliant (lead-free)
- Commercial temperature range -5°C to 70°C
- Single 3.3 V power supply
- Maximum link length of 10 km
- Uncooled 1310 nm DFB laser
- Receiver limiting electrical interface
- Duplex LC connector
- Built-in digital diagnostic functions

MRV's SFP-10GD-LR 10 Gbps Enhanced Small Form Factor Pluggable SFP+ transceivers are designed for use in 10-Gigabit Ethernet and 10 Gigabit Fibre Channel links up to 10km over single-mode fiber. They are compliant with SFF-8431, SFF-8432 and IEEE 802.3ae 10GBASE-LR/LW. Digital diagnostics functions are available via a 2-wire serial interface, as specified in SFF-8472. The SFP-10GD-LR is a "limiting module", i.e., it employs a limiting receiver. Host board designers using an EDC PHY IC should follow the IC manufacturer's recommended settings for interoperating the host-board EDC PHY with a limiting receiver SFP+ module. The transceiver is RoHS compliant and lead free per Directive 2002/95/EC.

Absolute Maximum Ratings*

Parameter	Symbol	Minimum	Typical	Maximum	Unit	Note
Maximum Supply Voltage	V_{CC}	-0.5	-	4.0	V	-
Case Operating Temperature	T_A	-5	-	70	°C	-
Storage Temperature	T_S	-40	-	85	°C	-
Relative Humidity (Non-Condensing)	RH	0	-	85	%	-

*Exceeding the limits listed in the table may damage the transceiver module permanently

Electrical Specifications

Parameter	Symbol	Minimum	Typical	Maximum	Unit	Note
Supply Voltage	V_{CC}	3.14	3.30	3.46	V	-
Supply Current	I_{CC}	-	200	285	mA	-
Transmitter						
Input Differential Impedance	R_{in}	-	100	-	Ω	1
Differential Data Input Swing	$V_{in, pp}$	180	-	700	mV	-
Transmit Disable Voltage	V_D	2	-	V_{CC}	V	-
Transmit Enable Voltage	V_{EN}	V_{EE}	-	$V_{EE}+0.8$	V	-
Receiver						
Differential Data Output Swing	$V_{out, pp}$	300	-	850	mV	2, 6
Output Rise Time, Fall Time	t_r, t_f	28	-	-	ps	3
LOS Fault	$V_{LOS\ fault}$	2	-	$V_{CC\ HOST}$	V	4
LOS Normal	$V_{LOS\ norm}$	V_{EE}	-	$V_{EE}+0.8$	V	4
Power Supply Noise Tolerance	$V_{CC\ T}/V_{CC\ R}$	Per SFF-8431 Rev 2.1			mVpp	5

- Notes:**
1. Connected directly to TX data input pins. AC coupling from pins into laser driver IC.
 2. Into 100 Ω differential termination.
 3. 20 – 80 % . Measured with Module Compliance Test Board and OMA test pattern. Use of four 1's and four 0's in sequence in the PRBS 9 is an acceptable alternative. SFF-8431 Rev 2.1
 4. LOS is an open collector output. Should be pulled up with 4.7k Ω – 10k Ω on the host board. Normal operation is logic 0; loss of signal is logic 1.
 5. See section 2.8.3 of SFF-8431. Rev 2.1
 6. The SFP-10GD-LR is a "limiting module", i.e., it employs a limiting receiver. Host board designers using an EDC PHY IC should follow the IC manufacturer's recommended settings for interoperating the host-board EDC PHY with a limiting receiver SFP+ module.

Datasheet

Pin Descriptions

Pin	Function	Name/Description	Note
1	V _{EET}	Transmitter Ground	1
2	T _{FAULT}	Transmitter Fault	2
3	T _{DIS}	Transmitter Disable. Laser output disabled on high or open.	3
4	SDA	2-wire Serial Interface Data Line	2
5	SCL	2-wire Serial Interface Clock Line	2
6	MOD_ABS	Module Absent. Grounded within the module.	2
7	RS0	Rate Select 0. Not Used.	4
8	RX_LOS	Loss of Signal indication. Logic 0 indicates normal operation.	5
9	RS1	Rate Select 1. Not Used.	4
10	V _{EER}	Receiver Ground	1
11	V _{EER}	Receiver Ground	1
12	RD-	Receiver Inverted DATA out. AC Coupled.	
13	RD+	Receiver Non-inverted DATA out. AC Coupled.	
14	V _{EER}	Receiver Ground	1
15	V _{CCR}	Receiver Power Supply	
16	V _{CCT}	Transmitter Power Supply	
17	V _{EET}	Transmitter Ground	1
18	TD+	Transmitter Non-Inverted DATA in. AC Coupled.	
19	TD-	Transmitter Inverted DATA in. AC Coupled.	
20	V _{EET}	Transmitter Ground	1

- Notes:**
1. Circuit ground is internally isolated from chassis ground.
 2. T_{FAULT} is an open collector/drain output, which should be pulled up with a 4.7k – 10k Ohms resistor on the host board if intended for use. Pull up voltage should be between 2.0V to V_{cc} + 0.3V. A high output indicates a transmitter fault caused by either the TX bias current or the TX output power exceeding the preset alarm thresholds. A low output indicates normal operation. In the low state, the output is pulled to <0.8V.
 3. Laser output disabled on T_{DIS} >2.0V or open, enabled on T_{DIS} <0.8V.
 4. Internally pulled down per SFF-8431 Rev 2.0
 5. LOS is open collector output. Should be pulled up with 4.7kΩ – 10kΩ on host board to a voltage between 2.0V and 3.6V. Logic 0 indicates normal operation; logic 1 indicates loss of signal.

Diagram of Host Board Connector Block Pin Numbers and Names

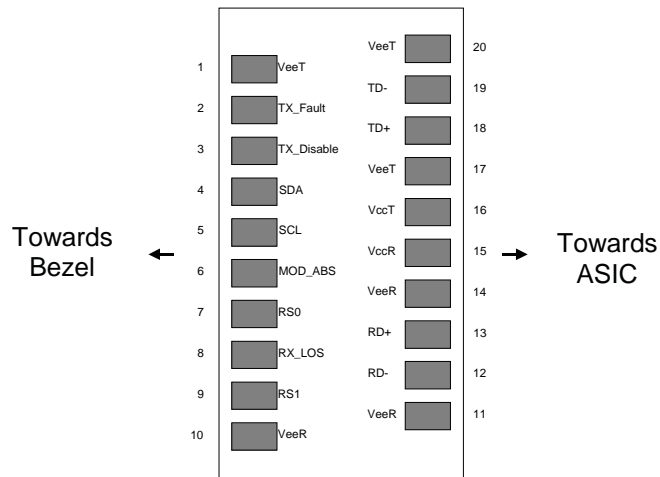

Datasheet

Optical Specifications

Parameter	Symbol	Minimum	Typical	Maximum	Unit	Note
Transmitter						
Optical Modulation Amplitude (OMA)	P_{OMA}	-5.2	-	-	dBm	-
Average Launch Power	P_{AVE}	-8.2	-	0.5	dBm	1
Optical Wavelength	λ	1260	-	1355	nm	-
Side-Mode Suppression Ratio	SMSR	30	-	-	dB	-
Optical Extinction Ratio	ER	3.5	-	-	dB	-
Transmitter and Dispersion Penalty	TDP	-	-	3.2	dB	-
Average Launch Power of OFF Transmitter	P_{off}	-	-	-30	dBm	-
Tx Jitter	T_{Xj}	Per IEEE 802.3ae requirements				-
Relative Intensity Noise	RIN	-	-	-128	dB/Hz	-
Receiver						
Receiver Sensitivity (OMA) @ 10.3Gbps	R_{SENS1}	-	-	-12.6	dBm	2
Stressed Receiver Sensitivity (OMA) @ 10.3Gbps	R_{SENS2}	-	-	-10.3	dBm	3
Average Receiver Power	P_{AVE}	-14.2	-	+ 0.5	dBm	-
Optical Center Wavelength	λ_C	1260	-	1600	nm	-
Receiver Reflectance	R_{rx}	-	-	-12	dB	-
LOS De-Assert	LOS_D	-	-	-17	dBm	-
LOS Assert	LOS_A	-30	-	-	dBm	-
LOS Hysteresis	-	0.5	-	-	dB	-

- Notes:**
1. Average Power figures are informative only, per IEEE802.3ae.
 2. Valid between 1260 and 1355 nm. Measured with worst ER; BER < 10^{-12} ; $2^{31} - 1$ PRBS.
 3. Valid between 1260 and 1355 nm. Per IEEE 802.3ae.

General Specifications

Parameter	Symbol	Minimum	Typical	Maximum	Unit	Note
Bit Rate	BR	9.95	10.3	10.52	Gbps	1
Bit Error Ratio	BER	-	-	10^{-12}	-	2
Max. Supported Link Length	S_{MAX}	-	10	-	km	1

- Notes:**
1. 10GBASE-LR, 10GBASE-LW, 10G Fibre Channel
 2. Tested with a $2^{31} - 1$ PRBS

Environmental Specifications

Parameter	Symbol	Minimum	Typical	Maximum	Unit	Note
Case Operating Temperature	T_{op}	-5	-	70	°C	-
Storage Temperature	T_{sto}	-40	-	85	°C	-

Regulatory and Industry Compliances

MRV transceivers are Class 1 Laser Products and comply with US FDA regulations. These products are certified by TÜV and CSA to meet the Class 1 eye safety requirements of EN (IEC) 60825 and the electrical safety requirements of EN (IEC) 60950. Copies of certificates are available at MRV Corporation upon request.

Datasheet

Digital Diagnostics Functions

MRV's SFP-10GD-LR SFP+ transceivers support the 2-wire serial communication protocol as defined in the SFF-8472. It is very closely related to the E²PROM defined in the GBIC standard, with the same electrical specifications.

The standard SFP serial ID provides access to identification information that describes the transceiver's capabilities, standard interfaces, manufacturer, and other information.

Additionally, MRV's SFP+ transceivers provide an enhanced digital diagnostic monitoring interface, which allows real-time access to device operating parameters such as transceiver temperature, laser bias current, transmitted optical power, received optical power and transceiver supply voltage. It also defines a sophisticated system of alarm and warning flags, which alerts end-users when particular operating parameters are outside of a factory set normal range.

The SFP MSA defines a 256-byte memory map in E²PROM that is accessible over a 2-wire serial interface at the 8 bit address 1010000X (A0h). The digital diagnostic monitoring interface makes use of the 8 bit address 1010001X (A2h), so the originally defined serial ID memory map remains unchanged. The interface is identical to, and is thus fully backward compatible with both the GBIC Specification and the SFP Multi Source Agreement.

The operating and diagnostics information is monitored and reported by a Digital Diagnostics Transceiver Controller (DDTC) inside the transceiver, which is accessed through a 2-wire serial interface. When the serial protocol is activated, the serial clock signal (SCL, Mod Def 1) is generated by the host. The positive edge clocks data into the SFP transceiver into those segments of the E²PROM that are not write-protected. The negative edge clocks data from the SFP transceiver. The serial data signal (SDA, Mod Def 2) is bi-directional for serial data transfer. The host uses SDA in conjunction with SCL to mark the start and end of serial protocol activation. The memories are organized as a series of 8-bit data words that can be addressed individually or sequentially.

For more information, please see the SFP MSA documentation.

SFP-10GD-LR transceivers can be used in host systems that require either internally or externally calibrated digital diagnostics.

Digital Diagnostics Specifications						
Parameter	Symbol	Min	Typical	Max	Unit	Note
Accuracy						
Internally Measured Transceiver Temperature	$\Delta DD_{Temperature}$	-	-	3	°C	-
Internally Measured Transceiver Supply Voltage	$\Delta DD_{Voltage}$	-	-	3	%	-
Measured TX Bias Current	ΔDD_{Bias}	-	-	10	%	1
Measured TX Output Power	$\Delta DD_{Tx-Power}$	-	-	2	dB	-
Measured RX Received Average Optical Power	$\Delta DD_{Rx-Power}$	-	-	2	dB	-
Dynamic Range for Rated Accuracy						
Internally Measured Transceiver Temperature	$DD_{Temperature}$	-5	-	70	°C	-
Internally Measured Transceiver Supply Voltage	$DD_{Voltage}$	3.1	-	3.5	V	-
Measured TX Bias Current	DD_{Bias}	0	-	TBD	mA	-
Measured TX Output Power	$DD_{Tx-Power}$	-8.2	-	0.5	dBm	-
Measured RX Received Average Optical Power	$DD_{Rx-Power}$	-14.2	-	0.5	dBm	-
Max Reporting Range						
Internally Measured Transceiver Temperature	$DD_{Temperature}$	-40	-	125	°C	-
Internally Measured Transceiver Supply Voltage	$DD_{Voltage}$	2.8	-	4.0	V	-
Measured TX Bias Current	DD_{Bias}	0	-	20	mA	-
Measured TX Output Power	$DD_{Tx-Power}$	-10	-	+2	dBm	-
Measured RX Received Average Optical Power	$DD_{Rx-Power}$	-22	-	+2	dBm	-

Notes: 1. Accuracy of Measured Tx Bias Current is 10% of the actual Bias Current from the laser driver to the laser.

Datasheet

Mechanical Dimensions

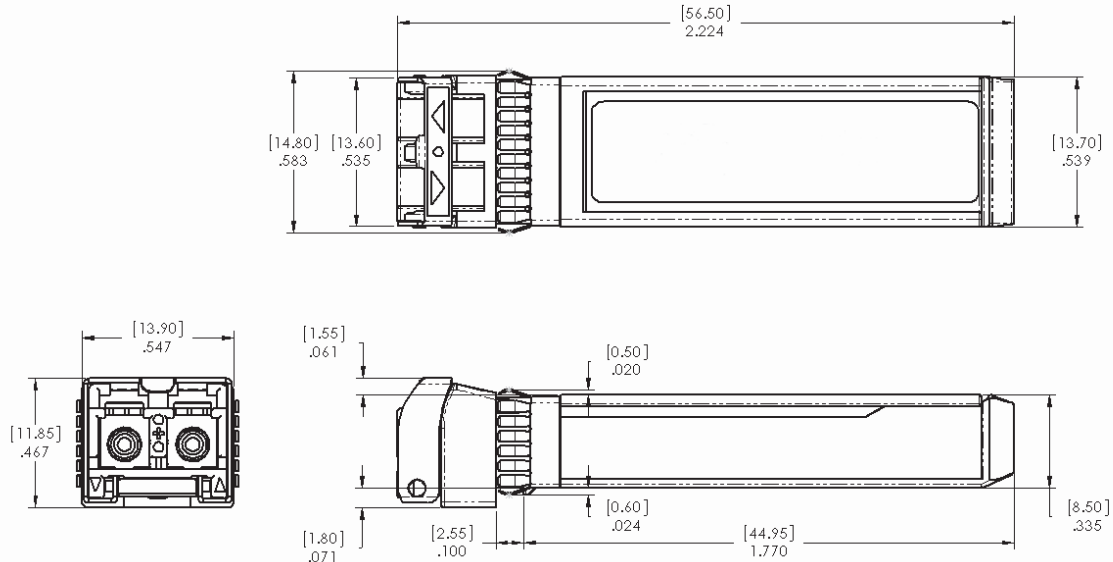

Mechanical Specifications

MRV's SFP-10GD-SX SFP+ transceivers are compatible with the SFF-8432 specification for improved pluggable form factor. Bail color is beige.

Ordering Information

Model	Description	Data Rate	Wavelength (nm)	Bail Latch Color	Max. Link Length (km)
SFP-10GD-LR	SFP+ Transceiver Single-Mode	9.95 - 10.52 Gbps	1310	Blue	0 - 10

MRV has more than 50 offices throughout the world. Addresses, phone numbers and fax numbers are listed at www.mrv.com. Please e-mail us at sales@mrv.com or call us for assistance.

MRV Los Angeles
20415 Nordhoff St.
Chatsworth, CA 91311
800-338-5316
818-773-0900

MRV Boston
295 Foster St.
Littleton, MA 01460
800-338-5316
978-952-4700

MRV International
Business Park Moerfelden
Waldeckerstrasse 13
64546 Moerfelden-Walldorf
Germany
Tel. (49) 6105/2070
Fax (49) 6105/207-100

All statements, technical information and recommendations related to the products herein are based upon information believed to be reliable or accurate. However, the accuracy or completeness thereof is not guaranteed, and no responsibility is assumed for any inaccuracies. Please contact MRV Communications for more information. MRV Communications and the MRV Communications logo are trademarks of MRV Communications, Inc. Other trademarks are the property of their respective holders.