

### FEATURES

- **Integrated NV SRAM, Real-Time Clock (RTC), Crystal, Power-Fail Control Circuit, and Lithium Energy Source**
- **Clock Registers are Accessed Identically to the Static RAM. These Registers are Resident in the Eight Top RAM Locations**
- **Century Byte Register (Y2K Compliant)**
- **Totally Nonvolatile with Over 10 Years of Operation in the Absence of Power**
- **BCD-Coded Century, Year, Month, Date, Day, Hours, Minutes, and Seconds with Automatic Leap Year Compensation Valid Up to the Year 2100**
- **Battery Voltage-Level Indicator Flag**
- **Power-Fail Write Protection Allows for  $\pm 10\%$   $V_{CC}$  Power-Supply Tolerance**
- **Lithium Energy Source is Electrically Disconnected to Retain Freshness Until Power is Applied for the First Time**
- **DIP Module Only:**  
Standard JEDEC Byte-Wide 512k x 8 Static RAM Pinout
- **PowerCap Module Board Only:**  
Surface-Mountable Package for Direct Connection to PowerCap Containing Battery and Crystal  
Replaceable Battery (PowerCap)  
Power-On Reset Output  
Pin-for-Pin Compatible with Other Densities of DS174xP Timekeeping RAM
- **Also Available in Industrial Temperature Range:  $-40^{\circ}\text{C}$  to  $+85^{\circ}\text{C}$**

### PIN CONFIGURATIONS

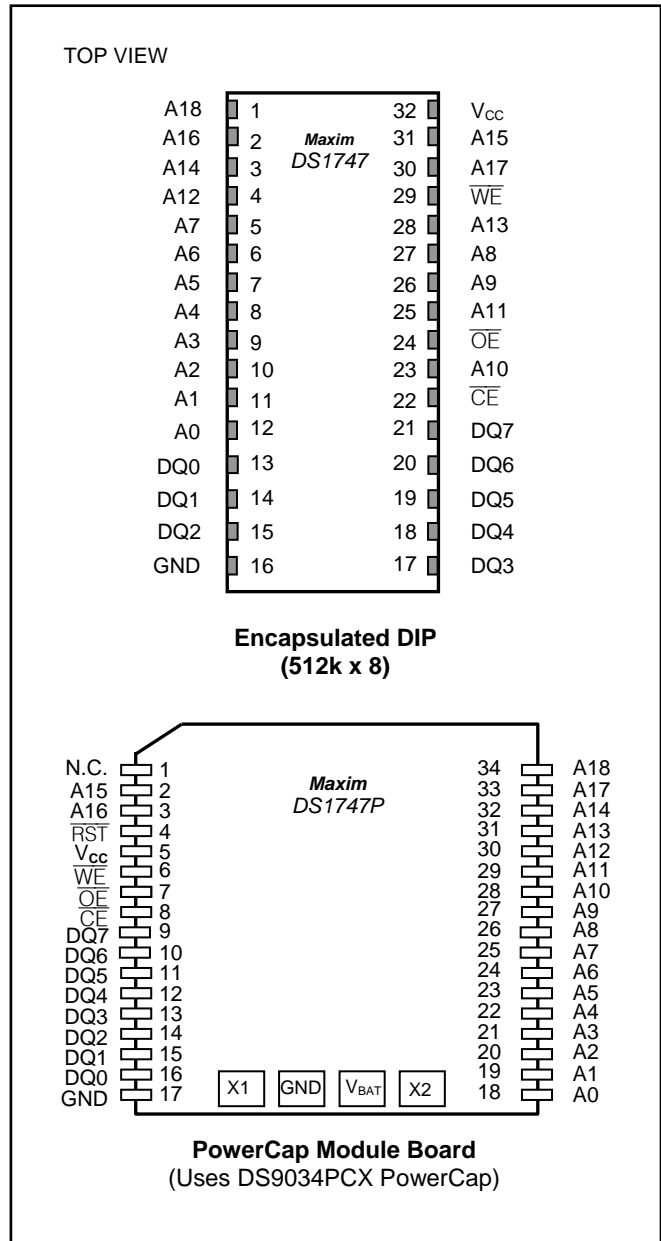

**Note:** Some revisions of this device may incorporate deviations from published specifications known as errata. Multiple revisions of any device may be simultaneously available through various sales channels. For information about device errata, click here: [www.maxim-ic.com/errata](http://www.maxim-ic.com/errata).

**PIN DESCRIPTION**

PIN		NAME	FUNCTION
EDIP	PowerCap		
1	34	A18	Address Input
2	3	A16	
3	32	A14	
4	30	A12	
5	25	A7	
6	24	A6	
7	23	A5	
8	22	A4	
9	21	A3	
10	20	A2	
11	19	A1	
12	18	A0	
23	28	A10	
25	29	A11	
26	27	A9	
27	26	A8	
28	31	A13	
30	33	A17	
31	2	A15	
13	16	DQ0	
14	15	DQ1	
15	14	DQ2	
17	13	DQ3	
18	12	DQ4	
19	11	DQ5	
20	10	DQ6	
21	9	DQ7	
16	17	GND	Ground
22	8	$\overline{\text{CE}}$	Active-Low Chip-Enable Input
24	7	$\overline{\text{OE}}$	Active-Low Output-Enable Input
29	6	$\overline{\text{WE}}$	Active-Low Write-Enable Input
32	5	V <sub>CC</sub>	Power-Supply Input
—	1	N.C.	No Connection
—	4	$\overline{\text{RST}}$	Active-Low Power-On Reset Output
—	(See Pin Configuration)	X1, X2	Crystal Input, Output Connections
—	(See Pin Configuration)	V <sub>BAT</sub>	Battery Connection

**ORDERING INFORMATION**

PART	SUPPLY VOLTAGE (V)	TEMP RANGE	PIN-PACKAGE	TOP MARK†
DS1747-70+	5.0	0°C to +70°C	32 EDIP (0.740a)	DS1747-70+
DS1747-70IND+	5.0	-40°C to +85°C	32 EDIP (0.740a)	DS1747-70IND+
DS1747P-70+	5.0	0°C to +70°C	34 PowerCap*	DS1747P+70
DS1747P-70IND+	5.0	-40°C to +85°C	34 PowerCap*	DS1747P+70 IND
DS1747W-120+	3.3	0°C to +70°C	32 EDIP (0.740a)	DS1747W-120+
DS1747W-120IND+	3.3	-40°C to +85°C	32 EDIP (0.740a)	DS1747W-120IND+
DS1747WP-120+	3.3	0°C to +70°C	34 PowerCap*	DS1747WP+120
DS1747WP-120IND+	3.3	-40°C to +85°C	34 PowerCap*	DS1747WP+120 IND

+ Denotes a lead(Pb)-free/RoHS-compliant package.

\*DS9034PCX+ or DS9034I-PCX+ required (must be ordered separately).

†A "+" indicates lead(Pb)-free. The top mark will include a "+" symbol on lead(Pb)-free devices.

**DESCRIPTION**

The DS1747 is a full-function, year-2000-compliant (Y2KC), real-time clock/calendar (RTC) and 512k x 8 nonvolatile static RAM. User access to all registers within the DS1747 is accomplished with a byte-wide interface as shown in Figure 1. The RTC information and control bits reside in the eight uppermost RAM locations. The RTC registers contain century, year, month, date, day, hours, minutes, and seconds data in 24-hour binary-coded decimal (BCD) format. Corrections for the date of each month and leap year are made automatically. The RTC clock registers are double buffered to avoid access of incorrect data that can occur during clock update cycles. The double-buffered system also prevents time loss as the timekeeping countdown continues unabated by access to time register data. The DS1747 also contains its own power-fail circuitry that deselected the device when the V<sub>CC</sub> supply is in an out-of-tolerance condition. This feature prevents loss of data from unpredictable system operation brought on by low V<sub>CC</sub> as errant access and update cycles are avoided.

Figure 1. Block Diagram

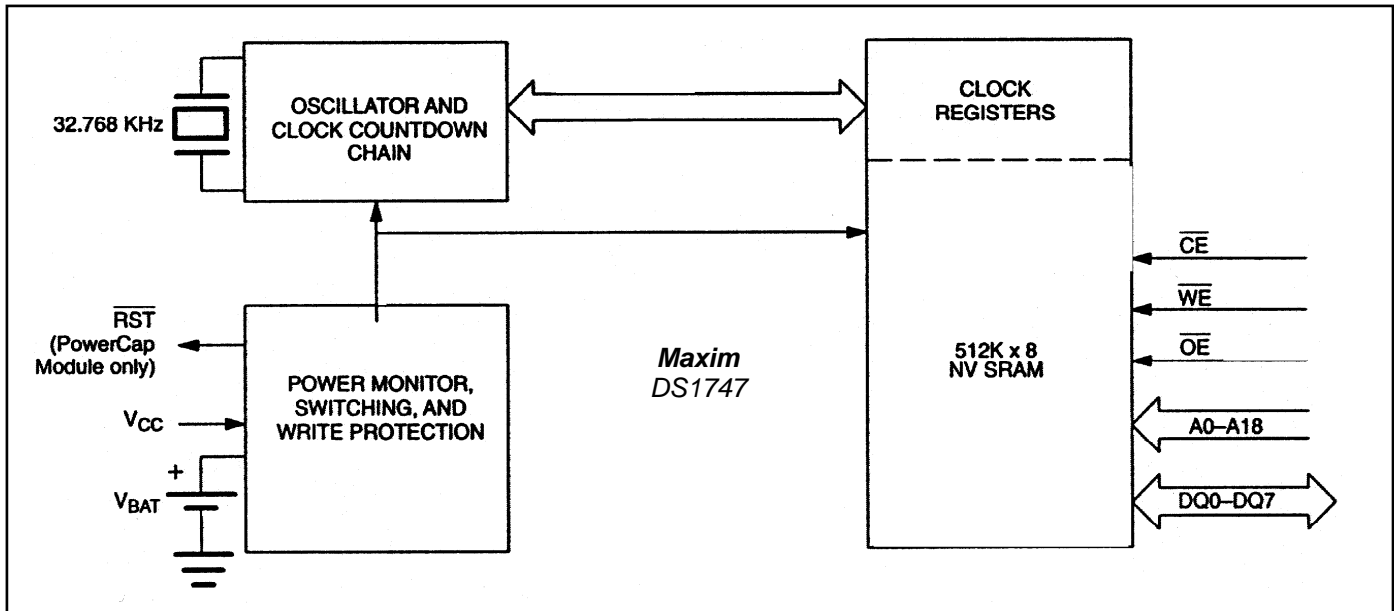

## PACKAGES

The DS1747 is available in two packages (32-pin DIP and 34-pin PowerCap module). The 32-pin DIP style module integrates the crystal, lithium energy source, and silicon all in one package. The 34-pin PowerCap Module Board is designed with contacts for connection to a separate PowerCap (DS9034PCX) that contains the crystal and battery. This design allows the Power-Cap to be mounted on top of the DS1747P after the completion of the surface mount process. Mounting the PowerCap after the surface mount process prevents damage to the crystal and battery due to the high temperatures required for solder reflow. The PowerCap is keyed to prevent reverse insertion. The PowerCap Module Board and PowerCap are ordered separately and shipped in separate containers. The part number for the PowerCap is DS9034PCX.

## TIME AND DATE OPERATIONS

The contents of the time and date registers are in BCD format. The day-of-week register increments at midnight. Values that correspond to the day of week are user-defined, but must be sequential (i.e., if 1 equals Sunday, then 2 equals Monday and so on). Illogical time and date entries result in undefined operation.

## CLOCK OPERATIONS—READING THE CLOCK

While the double-buffered register structure reduces the chance of reading incorrect data, internal updates to the DS1747 clock registers should be halted before clock data is read to prevent reading of data in transition. However, halting the internal clock register updating process does not affect clock accuracy. Updating is halted when a one is written into the read bit, bit 6 of the century register (see Table 2). As long as a one remains in that position, updating is halted. After a halt is issued, the registers reflect the count, that is day, date, and time that was current at the moment the halt command was issued. However, the internal clock registers of the double-buffered system continue to update so that the clock accuracy is not affected by the access of data. All the DS1747 registers are updated simultaneously after the internal clock register updating process has been re-enabled. Updating is within a second after the read bit is written to zero. The READ bit must be set to a zero for a minimum of 500 $\mu$ s to ensure the external registers will be updated.

**Table 1. Truth Table**

$V_{CC}$	$\overline{CE}$	$\overline{OE}$	$\overline{WE}$	MODE	DQ	POWER
$V_{CC} > V_{PF}$	$V_{IH}$	X	X	Deselect	High-Z	Standby
	$V_{IL}$	X	$V_{IL}$	Write	Data In	Active
	$V_{IL}$	$V_{IL}$	$V_{IH}$	Read	Data Out	Active
	$V_{IL}$	$V_{IH}$	$V_{IH}$	Read	High-Z	Active
$V_{SO} < V_{CC} < V_{PF}$	X	X	X	Deselect	High-Z	CMOS Standby
$V_{CC} < V_{SO} < V_{PF}$	X	X	X	Deselect	High-Z	Data-Retention Mode

## SETTING THE CLOCK

As shown in Table 2, bit 7 of the century register is the write bit. Setting the write bit to a one, like the read bit, halts updates to the DS1747 registers. The user can then load them with the correct day, date and time data in 24-hour format. Resetting the write bit to a zero then transfers those values to the actual clock counters and allows normal operation to resume.

## STOPPING AND STARTING THE CLOCK OSCILLATOR

The clock oscillator may be stopped at any time. To increase the shelf life, the oscillator can be turned off to minimize current drain from the battery. The  $\overline{OSC}$  bit is the MSB (bit 7) of the seconds registers, see Table 2. Setting it to a one stops the oscillator.

## FREQUENCY TEST BIT

As shown in Table 2, bit 6 of the day byte is the frequency test bit. When the frequency test bit is set to logic “1” and the oscillator is running, the LSB of the seconds register will toggle at 512Hz. When the seconds register is being read, the DQ0 line will toggle at the 512Hz frequency as long as conditions for access remain valid (i.e.,  $\overline{CE}$  low,  $\overline{OE}$  low,  $\overline{WE}$  high, and address for seconds register remain valid and stable).

## CLOCK ACCURACY (DIP MODULE)

The DS1747 is guaranteed to keep time accuracy to within  $\pm 1$  minute per month at  $+25^{\circ}\text{C}$ . The RTC is calibrated at the factory by Maxim using nonvolatile tuning elements, and does not require additional calibration. For this reason, methods of field clock calibration are not available and not necessary. The electrical environment also affects the clock accuracy, and caution should be taken to place the RTC in the lowest-level EMI section of the PC board layout. For additional information, refer to *Application Note 58*.

## CLOCK ACCURACY (PowerCap MODULE)

The DS1747 and DS9034PCX are each individually tested for accuracy. Once mounted together, the module typically keeps time accuracy to within  $\pm 1.53$  minutes per month (35 ppm) at  $+25^{\circ}\text{C}$ . Clock accuracy is also affected by the electrical environment and caution should be taken to place the RTC in the lowest-level EMI section of the PC board layout. For additional information, refer to *Application Note 58*.

**Table 2. Register Map**

ADDRESS	DATA								FUNCTION	RANGE	
	B7	B6	B5	B4	B3	B2	B1	B0			
7FFFF	10 Year				Year				Year	00-99	
7FFFE	X	X	X	10 Month	Month				Month	01-12	
7FFFD	X	X	10 Date		Date				Date	01-31	
7FFFC	BF	FT	X	X	X	Day			Day	01-07	
7FFFB	X	X	10 Hour		Hour				Hour	00-23	
7FFFA	X	10 Minutes				Minutes				Minutes	00-59
7FFF9	$\overline{\text{OSC}}$	10 Seconds				Seconds				Seconds	00-59
7FFF8	W	R	10 Century		Century				Century	00-39	

 $\overline{\text{OSC}}$  = Stop Bit

R = Read Bit

FT = Frequency Test

W = Write Bit

X = See Note

BF = Battery Flag

**NOTE:** All indicated "X" bits are unused, but must be set to "0" during write cycles to ensure proper clock operation.

## RETRIEVING DATA FROM RAM OR CLOCK

The DS1747 is in the read mode whenever  $\overline{\text{OE}}$  (output enable) is low,  $\overline{\text{WE}}$  (write enable) is high, and  $\overline{\text{CE}}$  (chip enable) is low. The device architecture allows ripple-through access to any of the address locations in the NV SRAM. Valid data will be available at the DQ pins within  $t_{AA}$  after the last address input is stable, providing that the  $\overline{\text{CE}}$  and  $\overline{\text{OE}}$  access times and states are satisfied. If  $\overline{\text{CE}}$  or  $\overline{\text{OE}}$  access times and states are not met, valid data will be available at the latter of chip-enable access ( $t_{CEA}$ ) or at output enable access time ( $t_{OEA}$ ). The state of the data input/output pins (DQ) is controlled by  $\overline{\text{CE}}$  and  $\overline{\text{OE}}$ . If the outputs are activated before  $t_{AA}$ , the data lines are driven to an intermediate state until  $t_{AA}$ . If the address inputs are changed while  $\overline{\text{CE}}$  and  $\overline{\text{OE}}$  remain valid, output data will remain valid for output data hold time ( $t_{OH}$ ) but will then go indeterminate until the next address access.

## WRITING DATA TO RAM OR CLOCK

The DS1747 is in the write mode whenever  $\overline{\text{WE}}$ , and  $\overline{\text{CE}}$  are in their active state. The start of a write is referenced to the latter occurring transition of  $\overline{\text{WE}}$  or  $\overline{\text{CE}}$ . The addresses must be held valid throughout the cycle.  $\overline{\text{CE}}$  or  $\overline{\text{WE}}$  must return inactive for a minimum of  $t_{WR}$  prior to the initiation of another read or write cycle. Data in must be valid  $t_{DS}$  prior to the end of write and remain valid for  $t_{DH}$  afterward. In a typical application, the  $\overline{\text{OE}}$  signal will be high during a write cycle. However,  $\overline{\text{OE}}$  can be active provided that care is taken with the data bus to avoid bus contention. If  $\overline{\text{OE}}$  is low prior to  $\overline{\text{WE}}$  transitioning low the data bus can become active with read data defined by the address inputs. A low transition on  $\overline{\text{WE}}$  will then disable the output  $t_{WEZ}$  after  $\overline{\text{WE}}$  goes active.

## DATA-RETENTION MODE

The 5V device is fully accessible and data can be written or read only when  $V_{CC}$  is greater than  $V_{PF}$ . However, when  $V_{CC}$  is below the power failing point,  $V_{PF}$ , (point at which write protection occurs) the internal clock registers and SRAM are blocked from any access. At this time the power fail reset output signal ( $\overline{RST}$ ) is driven active and will remain active until  $V_{CC}$  returns to nominal levels. When  $V_{CC}$  falls below the battery switch point  $V_{SO}$  (battery supply level), device power is switched from the  $V_{CC}$  pin to the backup battery. RTC operation and SRAM data are maintained from the battery until  $V_{CC}$  is returned to nominal levels. The 3.3V device is fully accessible and data can be written or read only when  $V_{CC}$  is greater than  $V_{PF}$ . When  $V_{CC}$  falls below the power fail point,  $V_{PF}$ , access to the device is inhibited. At this time the power fail reset output signal ( $\overline{RST}$ ) is driven active and will remain active until  $V_{CC}$  returns to nominal levels. If  $V_{PF}$  is less than  $V_{SO}$ , the device power is switched from  $V_{CC}$  to the backup supply ( $V_{BAT}$ ) when  $V_{CC}$  drops below  $V_{PF}$ . If  $V_{PF}$  is greater than  $V_{SO}$ , the device power is switched from  $V_{CC}$  to the backup supply ( $V_{BAT}$ ) when  $V_{CC}$  drops below  $V_{SO}$ . RTC operation and SRAM data are maintained from the battery until  $V_{CC}$  is returned to nominal levels. The  $\overline{RST}$  signal is an open drain output and requires a pull up. Except for the  $\overline{RST}$ , all control, data, and address signals must be powered down when  $V_{CC}$  is powered down.

## BATTERY LONGEVITY

The DS1747 has a lithium power source that is designed to provide energy for clock activity, and clock and RAM data retention when the  $V_{CC}$  supply is not present. The capability of this internal power supply is sufficient to power the DS1747 continuously for the life of the equipment in which it is installed. For specification purposes, the life expectancy is 10 years at +25°C with the internal clock oscillator running in the absence of  $V_{CC}$  power. Each DS1747 is shipped from Maxim with its lithium energy source disconnected, guaranteeing full energy capacity. When  $V_{CC}$  is first applied at a level greater than  $V_{PF}$ , the lithium energy source is enabled for battery backup operation. Actual life expectancy of the DS1747 will be much longer than 10 years since no lithium battery energy is consumed when  $V_{CC}$  is present.

## BATTERY MONITOR

The DS1747 constantly monitors the battery voltage of the internal battery. The Battery Flag bit (bit 7) of the day register is used to indicate the voltage level range of the battery. This bit is not writable and should always be a one when read. If a zero is ever present, an exhausted lithium energy source is indicated and both the contents of the RTC and RAM are questionable.

**ABSOLUTE MAXIMUM RATINGS**

Voltage Range on Any Pin Relative to Ground.....	-0.3V to +6.0V
Operating Temperature Range (Noncondensing)	
Commercial.....	0°C to +70°C
Industrial.....	-40°C to +85°C
Storage Temperature Range	
EDIP .....	-40°C to +85°C
PowerCap .....	-55°C to +125°C
Lead Temperature (soldering, 10s).....	+260°C
<b>Note:</b> EDIP is hand or wave-soldered only.	
Soldering Temperature (reflow, PowerCap) .....	+260°C

*This is a stress rating only and functional operation of the device at these or any other condition above those indicated in the operation sections of this specification is not implied. Exposure to absolute maximum rating conditions for extended periods of time may affect device reliability.*

**RECOMMENDED DC OPERATING CONDITIONS**

( $T_A$  = Over the Operating Range)

PARAMETER		SYMBOL	MIN	TYP	MAX	UNITS	NOTES
Logic 1 Voltage All Inputs	$V_{CC} = 5V \pm 10\%$	$V_{IH}$	2.2		$V_{CC} + 0.3V$	V	1
	$V_{CC} = 3.3V \pm 10\%$	$V_{IH}$	2.0		$V_{CC} + 0.3V$	V	1
Logic 0 Voltage All Inputs	$V_{CC} = 5V \pm 10\%$	$V_{IL}$	-0.3		+0.8	V	1
	$V_{CC} = 3.3V \pm 10\%$	$V_{IL}$	-0.3		+0.6	V	1

**DC ELECTRICAL CHARACTERISTICS**

( $V_{CC} = 5.0V \pm 10\%$ ,  $T_A$  = Over the Operating Range.)

PARAMETER	SYMBOL	MIN	TYP	MAX	UNITS	NOTES
Active Supply Current	$I_{CC}$			85	mA	2, 3, 10
TTL Standby Current ( $\overline{CE} = V_{IH}$ )	$I_{CC1}$			6	mA	2, 3
CMOS Standby Current ( $\overline{CE} \geq V_{CC} - 0.2V$ )	$I_{CC2}$			4	mA	2, 3
Input Leakage Current (Any Input)	$I_{IL}$	-1		+1	$\mu A$	
Output Leakage Current (Any Output)	$I_{OL}$	-1		+1	$\mu A$	
Output Logic 1 Voltage ( $I_{OUT} = -1.0mA$ )	$V_{OH}$	2.4				1
Output Logic 0 Voltage ( $I_{OUT} = +2.1mA$ )	$V_{OL}$			0.4		1
Write Protection Voltage	$V_{PF}$	4.25		4.50	V	1
Battery Switchover Voltage	$V_{SO}$		$V_{BAT}$			1, 4



**DC ELECTRICAL CHARACTERISTICS**(V<sub>CC</sub> = 3.3V ±10%, T<sub>A</sub> = Over the Operating Range.)

PARAMETER	SYMBOL	MIN	TYP	MAX	UNITS	NOTES
Active Supply Current	I <sub>CC</sub>			30	mA	2, 3, 10
TTL Standby Current ( $\overline{CE} = V_{IH}$ )	I <sub>CC1</sub>			2	mA	2, 3
CMOS Standby Current ( $\overline{CE} \geq V_{CC} - 0.2V$ )	I <sub>CC2</sub>			2	mA	2, 3
Input Leakage Current (Any Input)	I <sub>IL</sub>	-1		+1	μA	
Output Leakage Current (Any Output)	I <sub>OL</sub>	-1		+1	μA	
Output Logic 1 Voltage (I <sub>OUT</sub> = -1.0mA)	V <sub>OH</sub>	2.4				1
Output Logic 0 Voltage (I <sub>OUT</sub> = +2.1mA)	V <sub>OL</sub>			0.4		1
Write Protection Voltage	V <sub>PF</sub>	2.80		2.97	V	1
Battery Switchover Voltage	V <sub>SO</sub>		V <sub>BAT</sub> or V <sub>PF</sub>		V	1, 4

**AC CHARACTERISTICS—READ CYCLE (5V)**(V<sub>CC</sub> = 5.0V ±10%, T<sub>A</sub> = Over the Operating Range.)

PARAMETER	SYMBOL	MIN	TYP	MAX	UNITS	NOTES
Read Cycle Time	t <sub>RC</sub>	70			ns	
Address Access Time	t <sub>AA</sub>			70	ns	
$\overline{CE}$ to DQ Low-Z	t <sub>CEL</sub>	5			ns	
$\overline{CE}$ E Access Time	t <sub>CEA</sub>			70	ns	
$\overline{CE}$ Data Off Time	t <sub>CEZ</sub>			25	ns	
$\overline{OE}$ to DQ Low-Z	t <sub>OEL</sub>	5			ns	
$\overline{OE}$ Access Time	t <sub>OEA</sub>			35	ns	
$\overline{OE}$ Data Off Time	t <sub>OEZ</sub>			25	ns	
Output Hold from Address	t <sub>OH</sub>	5			ns	

### AC CHARACTERISTICS—READ CYCLE (3.3V)

( $V_{CC} = 3.3V \pm 10\%$ ,  $T_A =$  Over the Operating Range.)

PARAMETER	SYMBOL	MIN	TYP	MAX	UNITS	NOTES
Read Cycle Time	$t_{RC}$	120			ns	
Address Access Time	$t_{AA}$			120	ns	
$\overline{CE}$ to DQ Low-Z	$t_{CEL}$	5			ns	
$\overline{CE}$ E Access Time	$t_{CEA}$			120	ns	
$\overline{CE}$ Data Off Time	$t_{CEZ}$			40	ns	
$\overline{OE}$ to DQ Low-Z	$t_{OEL}$	5			ns	
$\overline{OE}$ Access Time	$t_{OEA}$			100	ns	
$\overline{OE}$ Data Off Time	$t_{OEZ}$			35	ns	
Output Hold from Address	$t_{OH}$	5			ns	

### READ CYCLE TIMING DIAGRAM

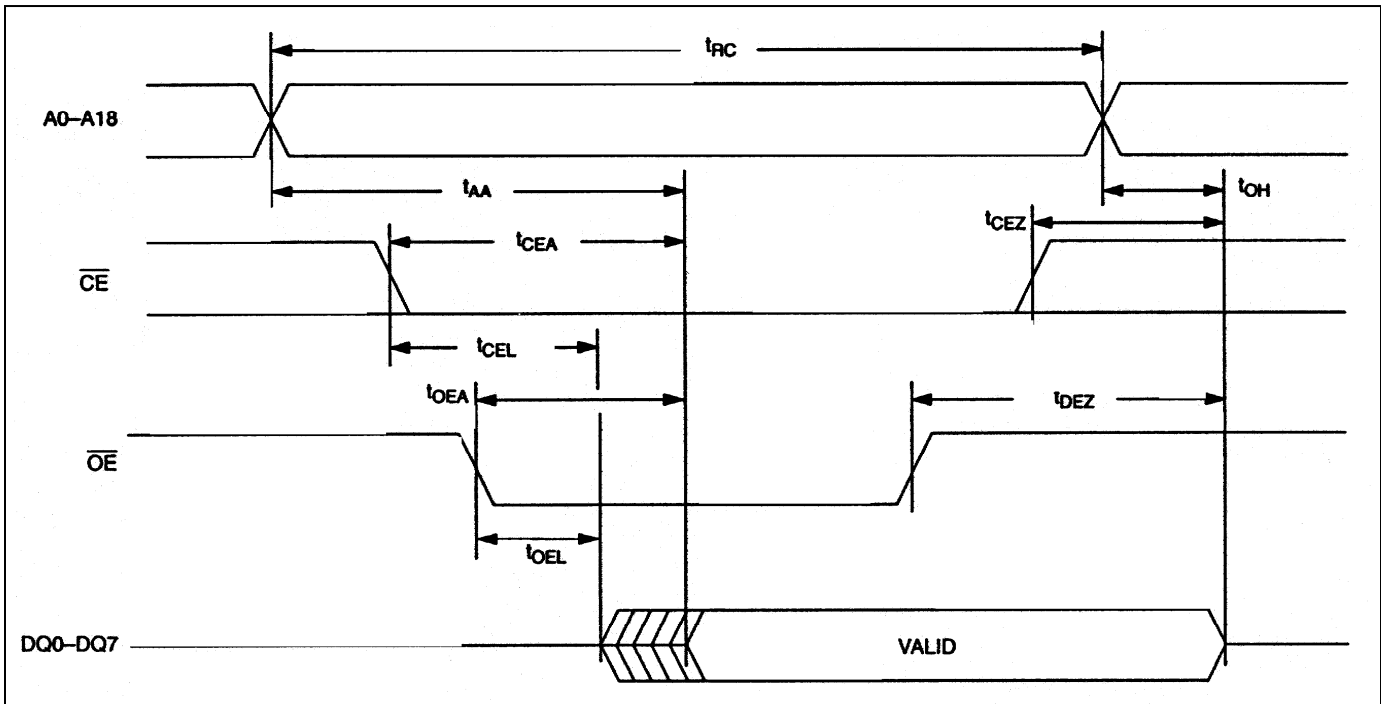

**AC CHARACTERISTICS—WRITE CYCLE (5V)**(V<sub>CC</sub> = 5.0V ±10%, T<sub>A</sub> = Over the Operating Range.)

PARAMETER	SYMBOL	MIN	TYP	MAX	UNITS	NOTES
Write Cycle Time	t <sub>WC</sub>	70			ns	
Address Setup Time	t <sub>AS</sub>	0			ns	
$\overline{\text{WE}}$ Pulse Width	t <sub>WEW</sub>	50			ns	
$\overline{\text{CE}}$ Pulse Width	t <sub>CEW</sub>	60			ns	
Data Setup Time	t <sub>DS</sub>	30			ns	
Data Hold Time	t <sub>DH1</sub>	0			ns	8
Data Hold Time	t <sub>DH2</sub>	0			ns	9
Address Hold Time	t <sub>AH1</sub>	5			ns	8
Address Hold Time	t <sub>AH2</sub>	5			ns	9
$\overline{\text{WE}}$ Data Off Time	t <sub>WEZ</sub>			25	ns	
Write Recovery Time	t <sub>WR</sub>	5			ns	

**AC CHARACTERISTICS—WRITE CYCLE (3.3V)**(V<sub>CC</sub> = 3.3V ±10%, T<sub>A</sub> = Over the Operating Range.)

PARAMETER	SYMBOL	MIN	TYP	MAX	UNITS	NOTES
Write Cycle Time	t <sub>WC</sub>	120			ns	
Address Setup Time	t <sub>AS</sub>	0		120	ns	
$\overline{\text{WE}}$ Pulse Width	t <sub>WEW</sub>	100			ns	
$\overline{\text{CE}}$ Pulse Width	t <sub>CEW</sub>	110			ns	
$\overline{\text{CE}}$ and CE2 Pulse Width	t <sub>CEW</sub>	110			ns	
Data Setup Time	t <sub>DS</sub>	80			ns	
Data Hold Time	t <sub>DH1</sub>	0			ns	8
Data Hold Time	t <sub>DH2</sub>	0			ns	9
Address Hold Time	t <sub>AH1</sub>	0			ns	8
Address Hold Time	t <sub>AH2</sub>	10			ns	9
$\overline{\text{WE}}$ Data Off Time	t <sub>WEZ</sub>			40	ns	
Write Recovery Time	t <sub>WR</sub>	10			ns	

**WRITE CYCLE TIMING DIAGRAM, WRITE-ENABLE CONTROLLED**

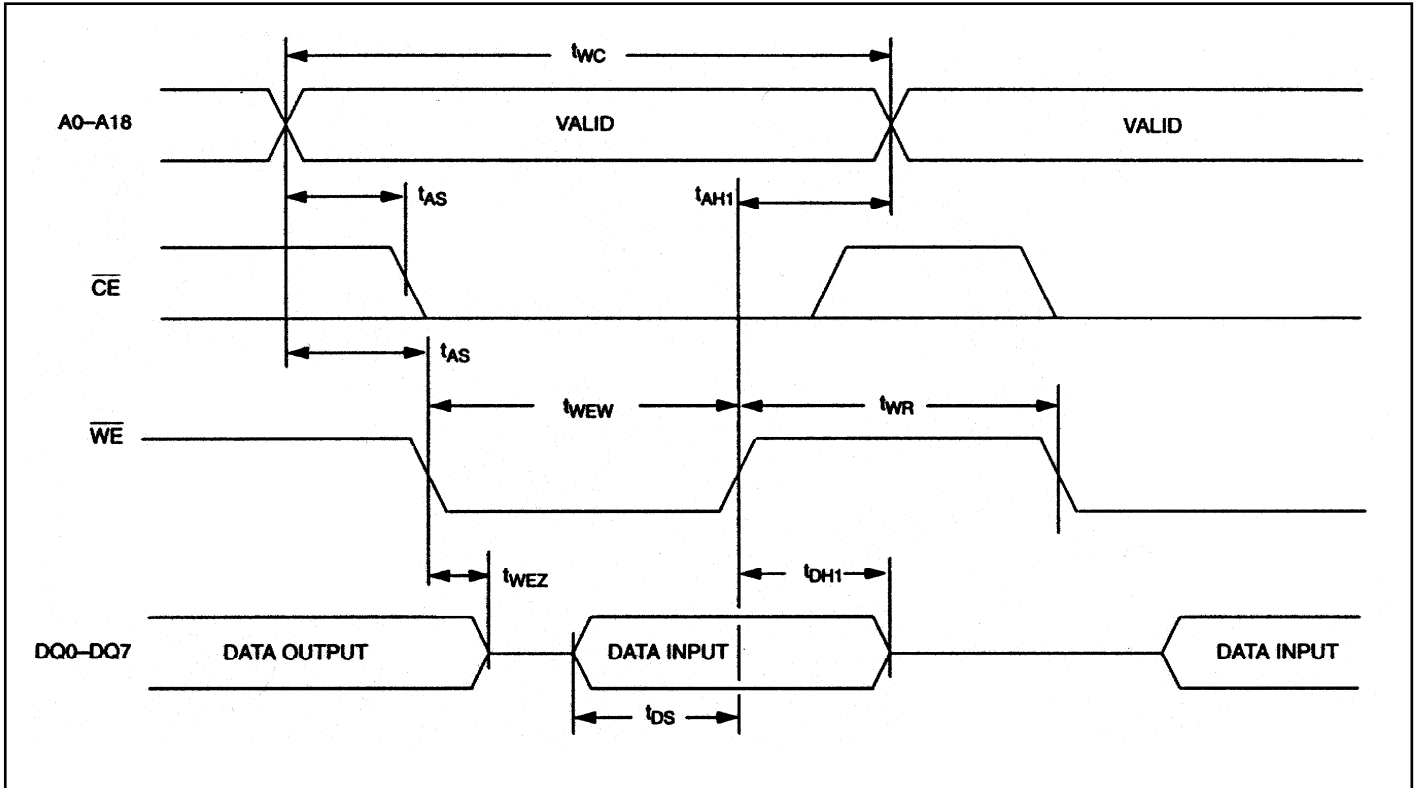

**WRITE CYCLE TIMING DIAGRAM, CHIP-ENABLE CONTROLLED**

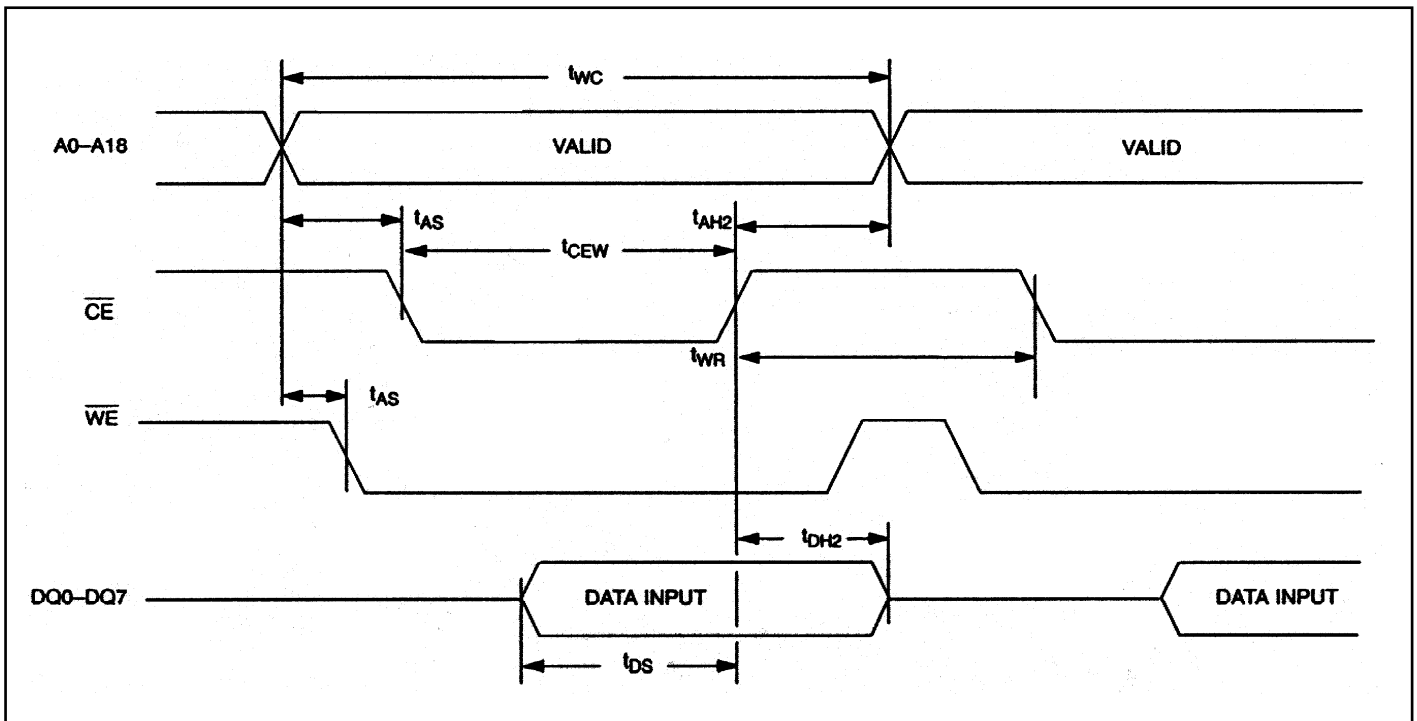

### POWER-UP/DOWN AC CHARACTERISTICS (5V)

( $V_{CC} = 5.0V \pm 10\%$ ,  $T_A =$  Over the Operating Range.)

PARAMETER	SYMBOL	MIN	TYP	MAX	UNITS	NOTES
$\overline{CE}$ or $\overline{WE}$ at $V_H$ Before Power-Down	$t_{PD}$	0			$\mu s$	
$V_{CC}$ Fall Time: $V_{PF(MAX)}$ to $V_{PF(MIN)}$	$t_F$	300			$\mu s$	
$V_{CC}$ Fall Time: $V_{PF(MIN)}$ to $V_{SO}$	$t_{FB}$	10			$\mu s$	
$V_{CC}$ Rise Time: $V_{PF(MIN)}$ to $V_{PF(MAX)}$	$t_R$	0			$\mu s$	
Power-Up Recover Time $V_{PF}$ to $\overline{RST}$ High (PowerCap Only)	$t_{REC}$			35	ms	
Expected Data-Retention Time (Oscillator ON)	$t_{DR}$	10			years	5, 6

### POWER-UP/DOWN TIMING (5V DEVICE)

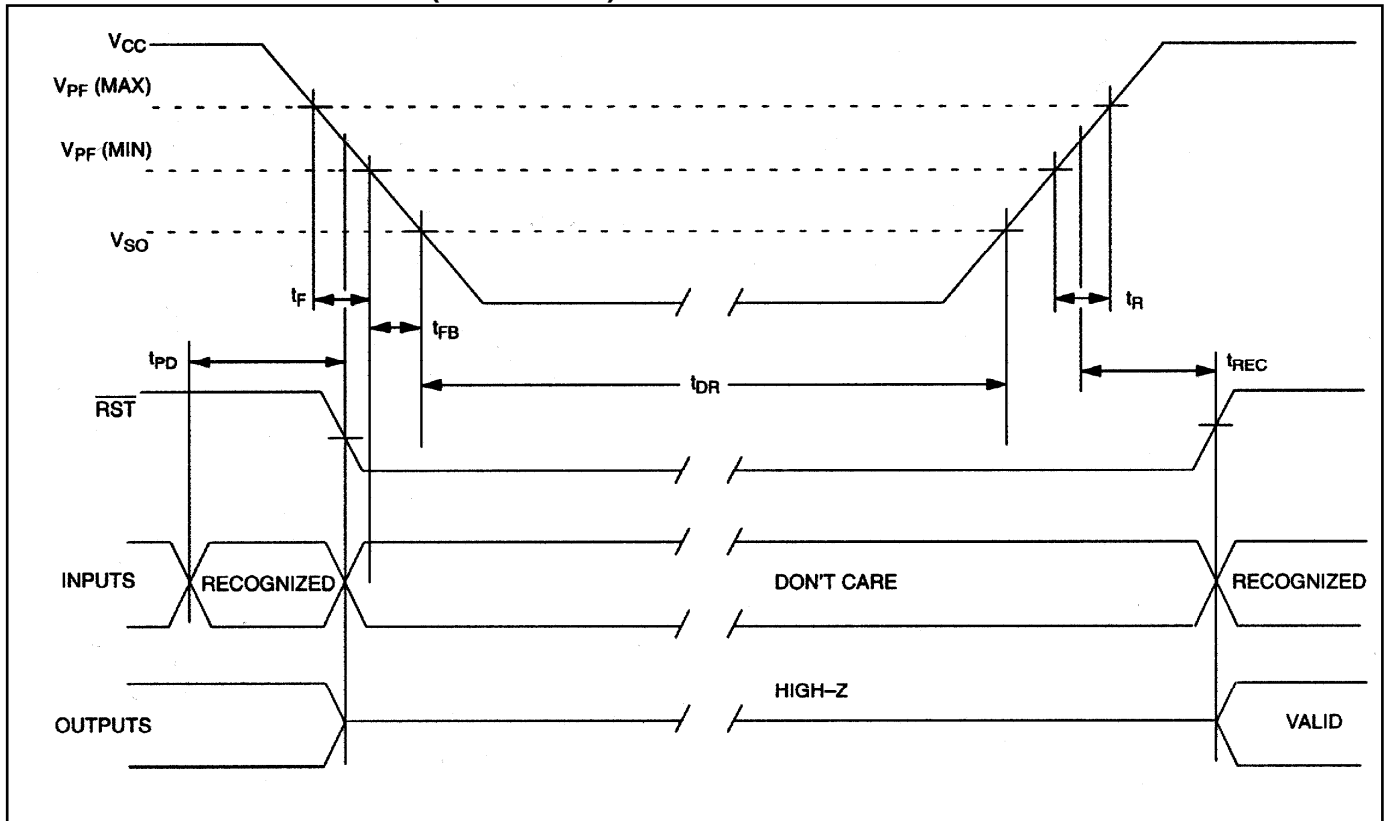

**POWER-UP/DOWN CHARACTERISTICS (3.3V)** $(V_{CC} = 3.3V \pm 10\%, T_A = \text{Over the Operating Range.})$ 

PARAMETER	SYMBOL	MIN	TYP	MAX	UNITS	NOTES
$\overline{CE}$ or $\overline{WE}$ at $V_H$ , Before Power-Down	$t_{PD}$	0			$\mu\text{s}$	
$V_{CC}$ Fall Time: $V_{PF(MAX)}$ to $V_{PF(MIN)}$	$t_F$	300			$\mu\text{s}$	
$V_{CC}$ Rise Time: $V_{PF(MIN)}$ to $V_{PF(MAX)}$	$t_R$	0			$\mu\text{s}$	
Power-Up Recover Time $V_{PF}$ to $\overline{RST}$ High (PowerCap Only)	$t_{REC}$			35	ms	
Expected Data-Retention Time (Oscillator ON)	$t_{DR}$	10			years	5, 6

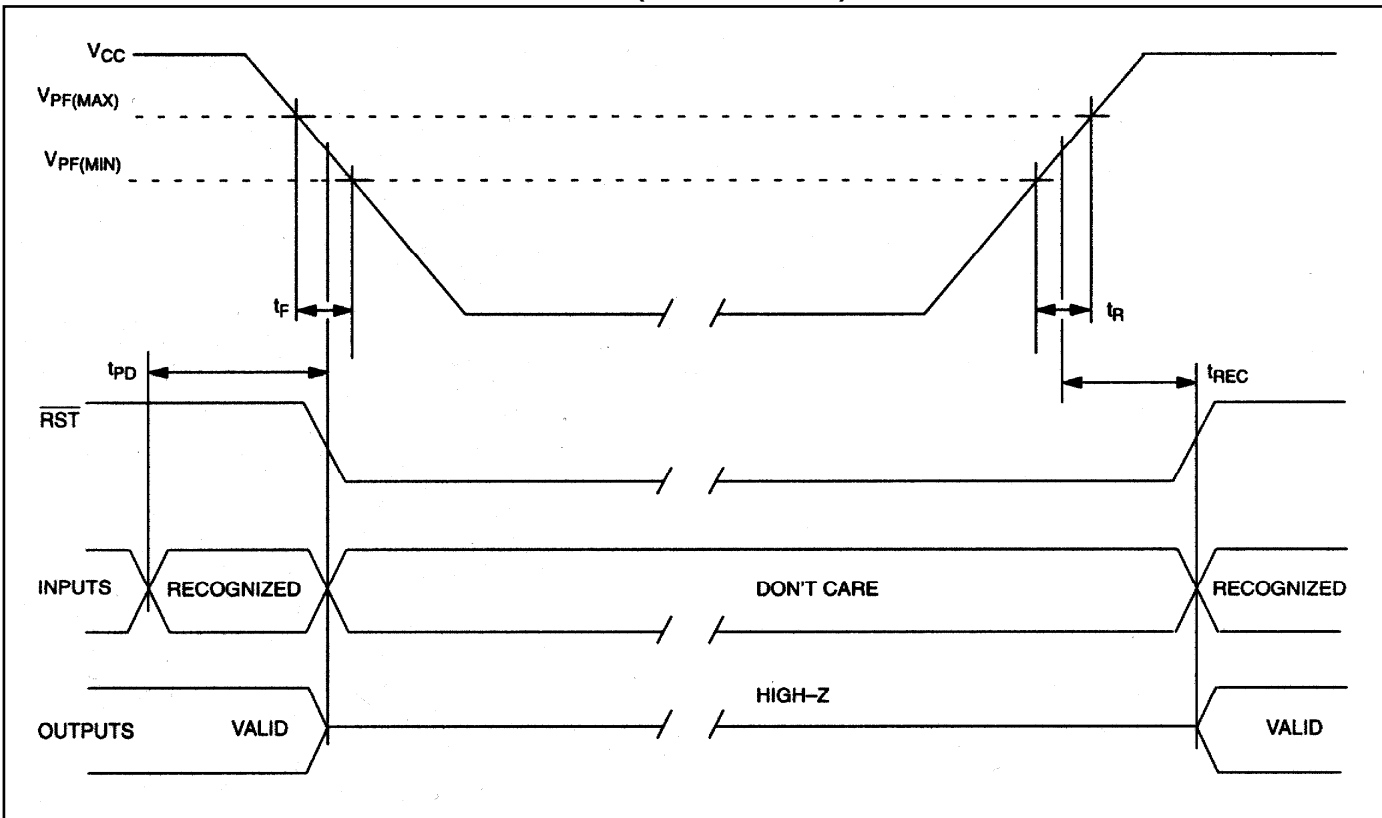
**POWER-UP/DOWN WAVEFORM TIMING (3.3V DEVICE)****CAPACITANCE** $(T_A = +25^\circ\text{C})$ 

PARAMETER	SYMBOL	MIN	TYP	MAX	UNITS	NOTES
Capacitance on All Input Pins	$C_{IN}$			14	pF	
Capacitance on All Output Pins	$C_O$			10	pF	

**AC TEST CONDITIONS**

Output Load: 50 pF + 1TTL Gate

Input Pulse Levels: 0 to 3.0V

Timing Measurement Reference Levels:

Input: 1.5V

Output: 1.5V

Input Pulse Rise and Fall Times: 5ns

**NOTES:**

- 1) Voltages are referenced to ground.
- 2) Typical values are at +25°C and nominal supplies.
- 3) Outputs are open.
- 4) Battery switchover occurs at the lower of either the battery terminal voltage or  $V_{PF}$ .
- 5) Data-retention time is at +25°C.
- 6) Each DS1747 has a built-in switch that disconnects the lithium source until the user first applies  $V_{CC}$ . The expected  $t_{DR}$  is defined for DIP modules and assembled PowerCap modules as accumulative time in the absence of  $V_{CC}$  starting from the time power is first applied by the user.
- 7) RTC encapsulated DIP (EDIP) modules can be successfully processed through conventional wave-soldering techniques as long as temperatures as long as temperature exposure to the lithium energy source contained within does not exceed +85°C. Post-solder cleaning with water-washing techniques is acceptable, provided that ultra-sonic vibration is not used.  
See the PowerCap package drawing on our website for details regarding the PowerCap package ([www.maxim-ic.com/packages](http://www.maxim-ic.com/packages)).
- 8)  $t_{AH1}$ ,  $t_{DH1}$  are measured from  $\overline{WE}$  going high.
- 9)  $t_{AH2}$ ,  $t_{DH2}$  are measured from  $\overline{CE}$  going high.
- 10)  $t_{WC} = 200ns$ .

**PACKAGE INFORMATION**

For the latest package outline information and land patterns, go to [www.maxim-ic.com/packages](http://www.maxim-ic.com/packages). Note that a "+", "#", or "-" in the package code indicates RoHS status only. Package drawings may show a different suffix character, but the drawing pertains to the package regardless of RoHS status.

PACKAGE TYPE	PACKAGE CODE	DOCUMENT NO.	LAND PATTERN NO.
32 EDIP	MDT32+4	<a href="#">21-0245</a>	—
34 PWRCP	PC2+1	<a href="#">21-0246</a>	—

**REVISION HISTORY**

<b>REVISION DATE</b>	<b>DESCRIPTION</b>	<b>PAGES CHANGED</b>
9/10	Updated the <i>Ordering Information</i> table top mark information and removed leaded parts; updated the <i>Absolute Maximum Ratings</i> section to include the storage temperature range and lead and soldering temperatures for EDIP and PowerCap packages; added Note 10 to the $I_{CC}$ parameter in the <i>DC Electrical Characteristics</i> tables (for 5.0V and 3.3V) and the <i>Notes</i> section; updated the <i>Package Information</i> table	3, 8, 9, 15

Maxim cannot assume responsibility for use of any circuitry other than circuitry entirely embodied in a Maxim product. No circuit patent licenses are implied. Maxim reserves the right to change the circuitry and specifications without notice at any time.

**Maxim Integrated Products, 120 San Gabriel Drive, Sunnyvale, CA 94086 408-737-7600**