

# HD74LS156

## Dual 2-line-to-4-line Decoders / Demultiplexers (with open collector outputs)

REJ03D0441-0300

Rev.3.00

Jul.13.2005

This circuit features dual 1-line-to-4-line demultiplexer with individual strobes and common binary-address input. When both sections are enabled by the strobes, the common binary-address inputs sequentially select and route associated input data to the appropriate output of each section. The individual strobes permit activating or inhibiting each of the 4-bit sections as desired. Data applied to input 1C is inverted through its outputs. The inverter following the 1C data input permits use as a 3-to-8-line decoder or 1-to-8-line demultiplexer without external gating.

### Features

- Ordering Information

Part Name	Package Type	Package Code (Previous Code)	Package Abbreviation	Taping Abbreviation (Quantity)
HD74LS156P	DILP-16 pin	PRDP0016AE-B (DP-16FV)	P	—
HD74LS156RPEL	SOP-16 pin (JEDEC)	PRSP0016DG-A (FP-16DNV)	FP	EL (2,500 pcs/reel)

Note: Please consult the sales office for the above package availability.

### Pin Arrangement

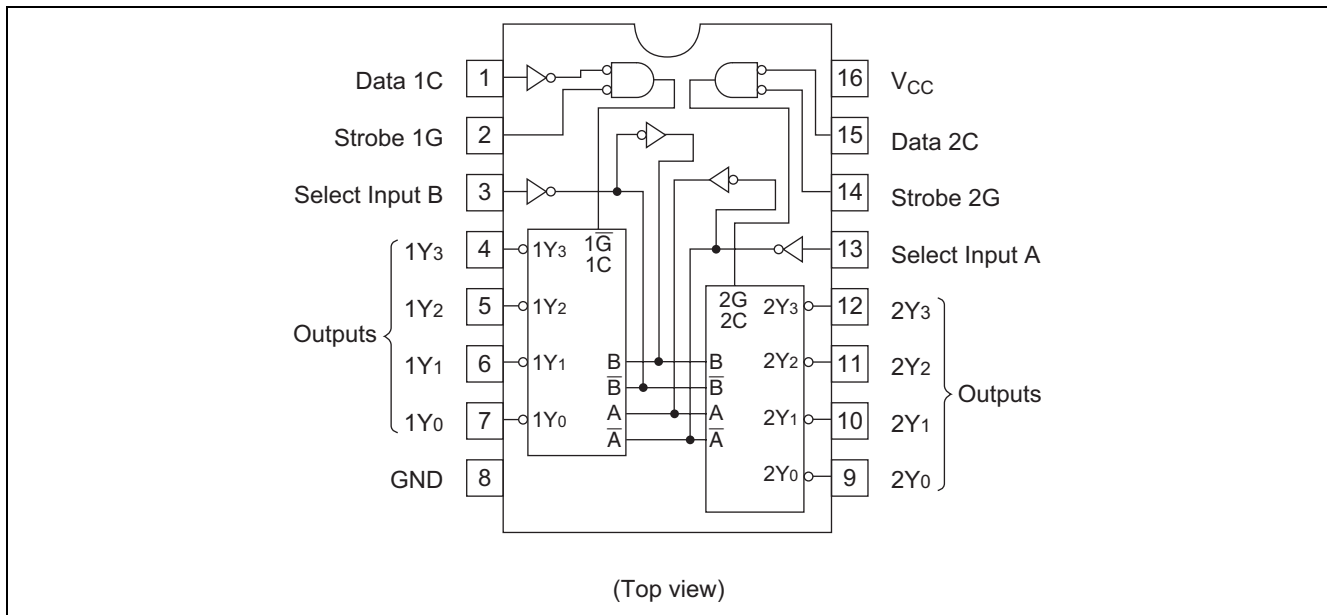

## Function Table

### • 2-to-4-line Decoder / 1-to-4-line Demultiplexer

Inputs				Outputs			
Select		Strobe	Data	1Y <sub>0</sub>	1Y <sub>1</sub>	1Y <sub>2</sub>	1Y <sub>3</sub>
B	A	1G	1C				
X	X	H	X	H	H	H	H
L	L	L	H	L	H	H	H
L	H	L	H	H	L	H	H
H	L	L	H	H	H	L	H
H	H	L	H	H	H	H	L
X	X	X	L	H	H	H	H

Inputs				Outputs			
Select		Strobe	Data	2Y <sub>0</sub>	2Y <sub>1</sub>	2Y <sub>2</sub>	2Y <sub>3</sub>
B	A	2G	2C				
X	X	H	X	H	H	H	H
L	L	L	L	L	H	H	H
L	H	L	L	H	L	H	H
H	L	L	L	H	H	L	H
H	H	L	L	H	H	H	L
X	X	X	H	H	H	H	H

### • 3-to-8-line Decoder / 1-to-8-line Demultiplexer

Inputs				Outputs							
Select			Strobe or Data	(0)	(1)	(2)	(3)	(4)	(5)	(6)	(7)
C <sup>*1</sup>	B	A	G <sup>*2</sup>	2Y <sub>0</sub>	2Y <sub>1</sub>	2Y <sub>2</sub>	2Y <sub>3</sub>	1Y <sub>0</sub>	1Y <sub>1</sub>	1Y <sub>2</sub>	1Y <sub>3</sub>
X	X	X	H	H	H	H	H	H	H	H	H
L	L	L	L	L	H	H	H	H	H	H	H
L	L	H	L	H	L	H	H	H	H	H	H
L	H	L	L	H	H	L	H	H	H	H	H
L	H	H	L	H	H	H	L	H	H	H	H
H	L	L	L	H	H	H	H	L	H	H	H
H	L	H	L	H	H	H	H	H	L	H	H
H	H	L	L	H	H	H	H	H	H	L	H
H	H	H	L	H	H	H	H	H	H	H	L

- Notes: 1. C; input 1C and 2C connected together  
 2. G; inputs 1G and 2G connected together  
 3. H; high level, L; low level, X; irrelevant

**Block Diagram**

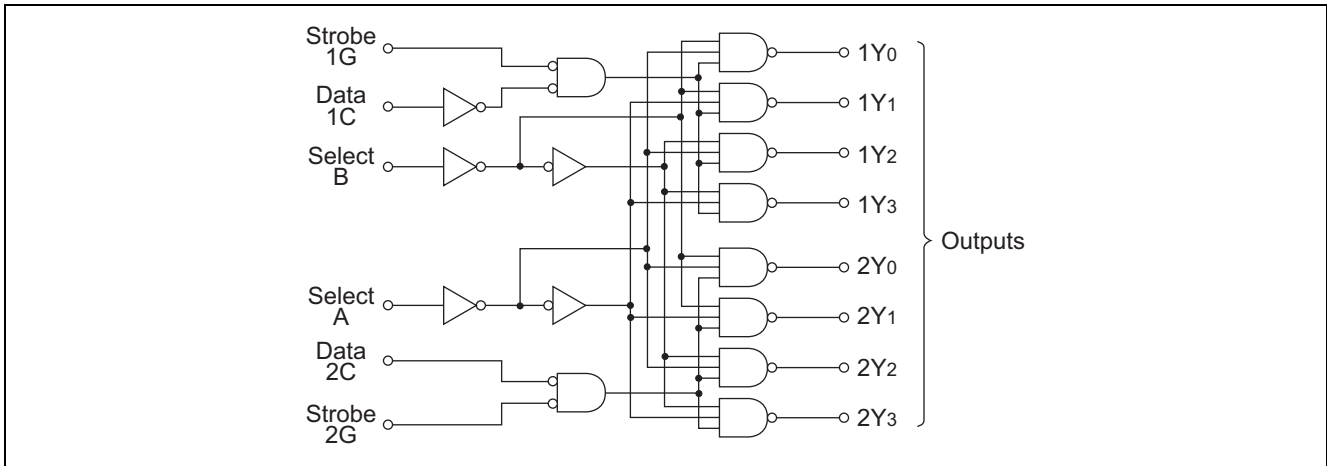

**Absolute Maximum Ratings**

Item	Symbol	Ratings	Unit
Supply voltage	$V_{CC}$	7	V
Input voltage	$V_{IN}$	7	V
Power dissipation	$P_T$	400	mW
Storage temperature	$T_{stg}$	-65 to +150	°C

Note: Voltage value, unless otherwise noted, are with respect to network ground terminal.

**Recommended Operating Conditions**

Item	Symbol	Min	Typ	Max	Unit
Supply voltage	$V_{CC}$	4.75	5.00	5.25	V
High level output voltage	$V_{OH}$	—	—	5.5	V
Low level output current	$I_{OL}$	—	—	8	mA
Operating temperature	$T_{opr}$	-20	25	75	°C

**Electrical Characteristics**

( $T_a = -20$  to  $+75$  °C)

Item	Symbol	min.	typ.*	max.	Unit	Condition
Input voltage	$V_{IH}$	2.0	—	—	V	
	$V_{IL}$	—	—	0.8	V	
Output current	$I_{OH}$	—	—	100	μA	$V_{CC} = 4.75$ V, $V_{IH} = 2$ V, $V_{IL} = 0.8$ V, $V_{OH} = 5.5$ V
Output voltage	$V_{OL}$	—	—	0.4	V	$V_{CC} = 4.75$ V, $V_{IH} = 2$ V, $V_{IL} = 0.8$ V
		—	—	0.5		
Input current	$I_{IH}$	—	—	20	μA	$V_{CC} = 5.25$ V, $V_I = 2.7$ V
	$I_{IL}$	—	—	-0.4	mA	$V_{CC} = 5.25$ V, $V_I = 0.4$ V
	$I_I$	—	—	0.1	mA	$V_{CC} = 5.25$ V, $V_I = 7$ V
Supply current**	$I_{CC}$	—	6.1	10	mA	$V_{CC} = 5.25$ V
Input clamp voltage	$V_{IK}$	—	—	-1.5	V	$V_{CC} = 4.75$ V, $I_{IN} = -18$ mA

Notes: \*  $V_{CC} = 5$  V,  $T_a = 25$ °C

\*\*  $I_{CC}$  is measured with outputs open, A, B, and 1C inputs at 4.5 V, and 2C, 1G, and 2G inputs grounded.

Switching Characteristics

( $V_{CC} = 5\text{ V}$ ,  $T_a = 25^\circ\text{C}$ )

Item	Symbol	Inputs	Output	Level of logic	min.	typ.	max.	Unit	Condition
Propagation delay time	$t_{PLH}$	A, B, 2C, 1G or 2G	Y	2	—	25	40	ns	$C_L = 15\text{ pF}$ , $R_L = 2\text{ k}\Omega$
	$t_{PHL}$	A, B, 2C, 1G or 2G	Y	2	—	34	51		
	$t_{PLH}$	A or B	Y	3	—	31	46		
	$t_{PHL}$	A or B	Y	3	—	34	51		
	$t_{PLH}$	1C	Y	3	—	32	48		
	$t_{PHL}$	1C	Y	3	—	32	48		

Testing Method

Test Circuit

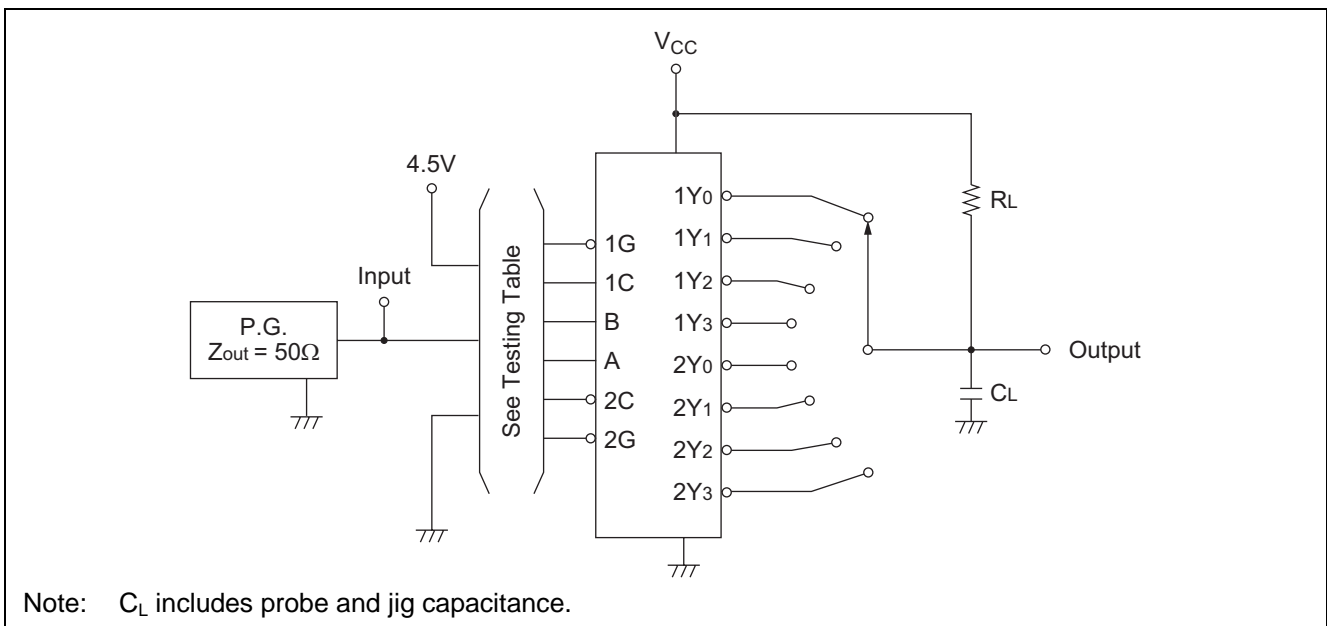

Waveform

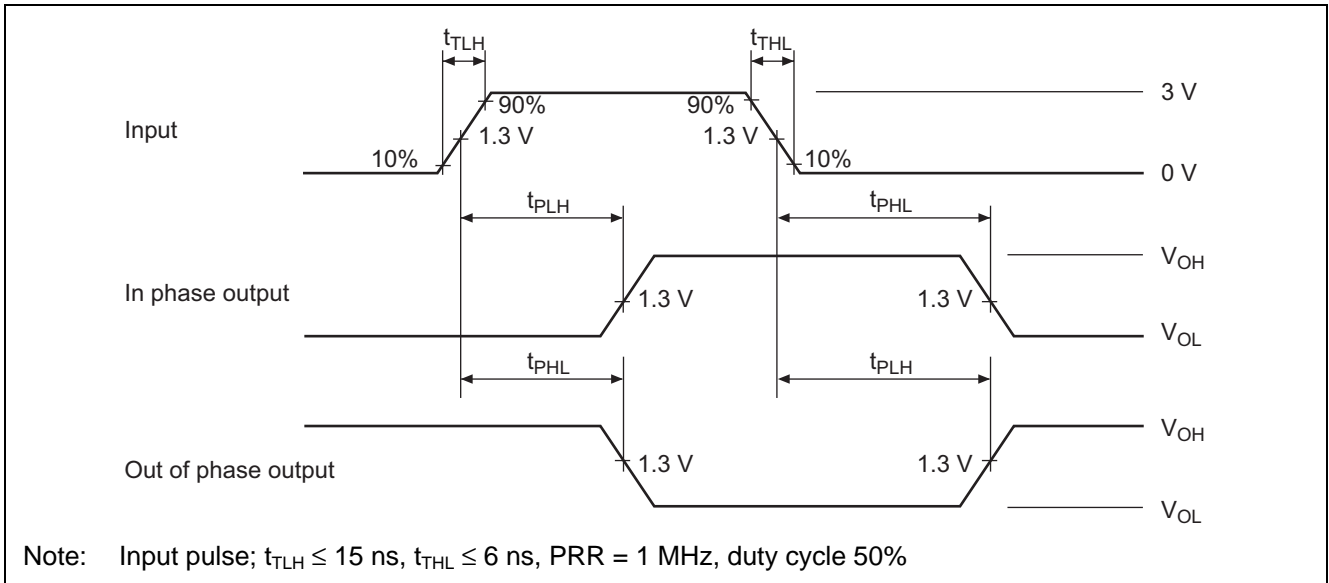

Package Dimensions

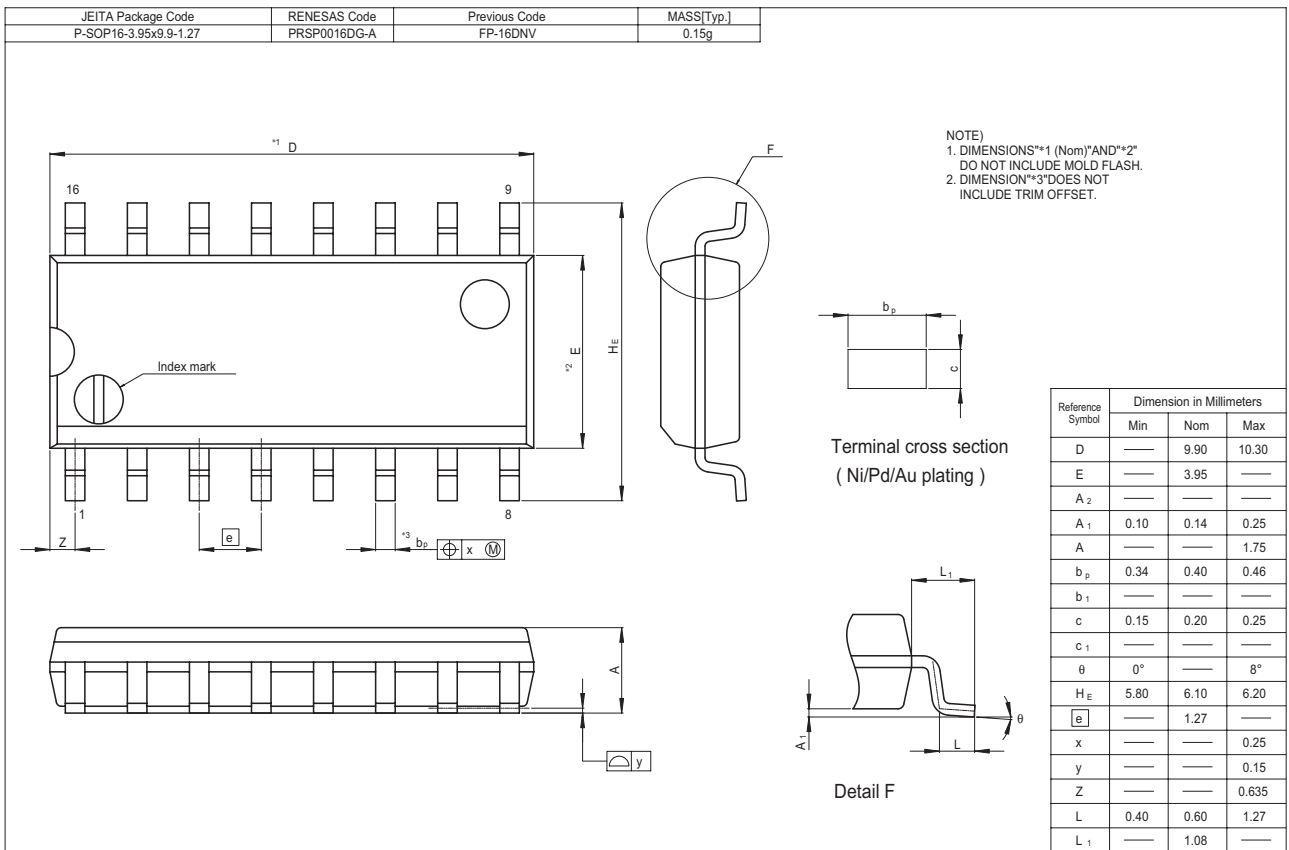
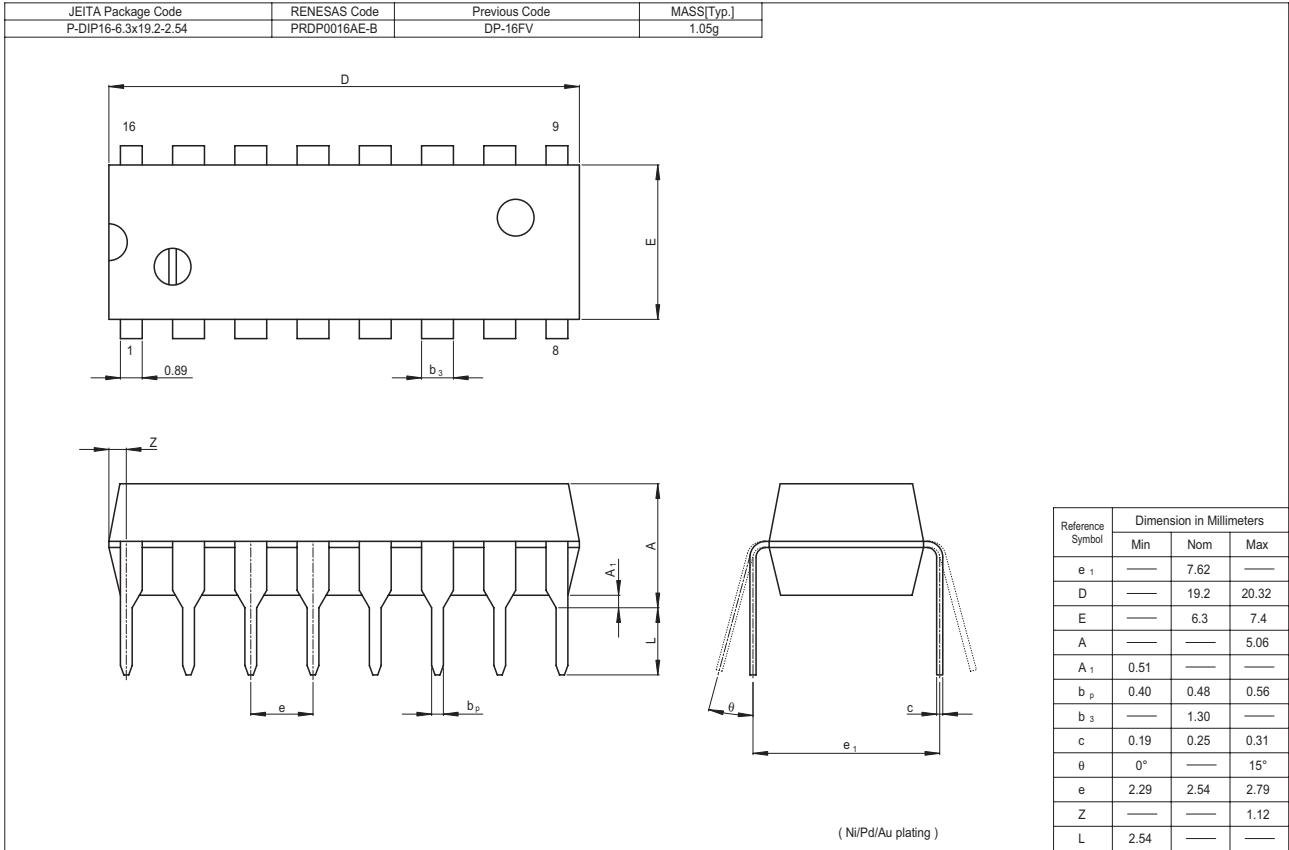

## Renesas Technology Corp. Sales Strategic Planning Div. Nippon Bldg., 2-6-2, Ohte-machi, Chiyoda-ku, Tokyo 100-0004, Japan

Keep safety first in your circuit designs!

1. Renesas Technology Corp. puts the maximum effort into making semiconductor products better and more reliable, but there is always the possibility that trouble may occur with them. Trouble with semiconductors may lead to personal injury, fire or property damage. Remember to give due consideration to safety when making your circuit designs, with appropriate measures such as (i) placement of substitutive, auxiliary circuits, (ii) use of nonflammable material or (iii) prevention against any malfunction or mishap.

Notes regarding these materials

1. These materials are intended as a reference to assist our customers in the selection of the Renesas Technology Corp. product best suited to the customer's application; they do not convey any license under any intellectual property rights, or any other rights, belonging to Renesas Technology Corp. or a third party.
2. Renesas Technology Corp. assumes no responsibility for any damage, or infringement of any third-party's rights, originating in the use of any product data, diagrams, charts, programs, algorithms, or circuit application examples contained in these materials.
3. All information contained in these materials, including product data, diagrams, charts, programs and algorithms represents information on products at the time of publication of these materials, and are subject to change by Renesas Technology Corp. without notice due to product improvements or other reasons. It is therefore recommended that customers contact Renesas Technology Corp. or an authorized Renesas Technology Corp. product distributor for the latest product information before purchasing a product listed herein.  
The information described here may contain technical inaccuracies or typographical errors.  
Renesas Technology Corp. assumes no responsibility for any damage, liability, or other loss rising from these inaccuracies or errors.  
Please also pay attention to information published by Renesas Technology Corp. by various means, including the Renesas Technology Corp. Semiconductor home page (<http://www.renesas.com>).
4. When using any or all of the information contained in these materials, including product data, diagrams, charts, programs, and algorithms, please be sure to evaluate all information as a total system before making a final decision on the applicability of the information and products. Renesas Technology Corp. assumes no responsibility for any damage, liability or other loss resulting from the information contained herein.
5. Renesas Technology Corp. semiconductors are not designed or manufactured for use in a device or system that is used under circumstances in which human life is potentially at stake. Please contact Renesas Technology Corp. or an authorized Renesas Technology Corp. product distributor when considering the use of a product contained herein for any specific purposes, such as apparatus or systems for transportation, vehicular, medical, aerospace, nuclear, or undersea repeater use.
6. The prior written approval of Renesas Technology Corp. is necessary to reprint or reproduce in whole or in part these materials.
7. If these products or technologies are subject to the Japanese export control restrictions, they must be exported under a license from the Japanese government and cannot be imported into a country other than the approved destination.  
Any diversion or reexport contrary to the export control laws and regulations of Japan and/or the country of destination is prohibited.
8. Please contact Renesas Technology Corp. for further details on these materials or the products contained therein.



### RENESAS SALES OFFICES

<http://www.renesas.com>

Refer to "<http://www.renesas.com/en/network>" for the latest and detailed information.

#### Renesas Technology America, Inc.

450 Holger Way, San Jose, CA 95134-1368, U.S.A  
Tel: <1> (408) 382-7500, Fax: <1> (408) 382-7501

#### Renesas Technology Europe Limited

Dukes Meadow, Millboard Road, Bourne End, Buckinghamshire, SL8 5FH, U.K.  
Tel: <44> (1628) 585-100, Fax: <44> (1628) 585-900

#### Renesas Technology Hong Kong Ltd.

7th Floor, North Tower, World Finance Centre, Harbour City, 1 Canton Road, Tsimshatsui, Kowloon, Hong Kong  
Tel: <852> 2265-6688, Fax: <852> 2730-6071

#### Renesas Technology Taiwan Co., Ltd.

10th Floor, No.99, Fushing North Road, Taipei, Taiwan  
Tel: <886> (2) 2715-2888, Fax: <886> (2) 2713-2999

#### Renesas Technology (Shanghai) Co., Ltd.

Unit2607 Ruijing Building, No.205 Maoming Road (S), Shanghai 200020, China  
Tel: <86> (21) 6472-1001, Fax: <86> (21) 6415-2952

#### Renesas Technology Singapore Pte. Ltd.

1 Harbour Front Avenue, #06-10, Keppel Bay Tower, Singapore 098632  
Tel: <65> 6213-0200, Fax: <65> 6278-8001

#### Renesas Technology Korea Co., Ltd.

Kukje Center Bldg. 18th Fl., 191, 2-ka, Hangang-ro, Yongsan-ku, Seoul 140-702, Korea  
Tel: <82> 2-796-3115, Fax: <82> 2-796-2145

#### Renesas Technology Malaysia Sdn. Bhd.

Unit 906, Block B, Menara Amcorp, Amcorp Trade Centre, No.18, Jalan Persiaran Barat, 46050 Petaling Jaya, Selangor Darul Ehsan, Malaysia  
Tel: <603> 7955-9390, Fax: <603> 7955-9510