

Adjustable shunt regulator

LM432XA3/N3

Description

The LM432 is a three terminal adjustable shunt regulator with thermal stability guaranteed over temperature. The output voltage can be adjusted to any value from 1.24V(V_{REF}) to 20V with two external resistors. The LM432 has a typical dynamic output impedance of $0.05\ \Omega$. Active output circuitry provides a very sharp turn on characteristic, making the LM432 an excellent replacement for zener diodes. The LM432 shunt regulator is available with four voltage tolerances(0.25%,0.5%,1% and 2%), and two package options(TO-92 and SOT-23). This allows the designer the opportunity to select the optimum combination of cost and performance for their application.

Features

- ◆ Low voltage operation(down to 1.24V)
- ◆ Wide operating current range $80\ \mu\text{A}$ to 100mA
- ◆ Low dynamic output impedance $0.05\ \Omega$ typ.
- ◆ Trimmed bandgap design $\pm 0.25\%$
- ◆ Upgrade for LM431
- ◆ Available in TO-92 and SOT-23 packages

Applications

- ◆ Linear Regulators
- ◆ Adjustable Supplies
- ◆ Switching Power Supplies
- ◆ Battery Operated Computers
- ◆ Instrumentation
- ◆ Computer Disk Drives

Typical Application Circuit(Note 1,2)

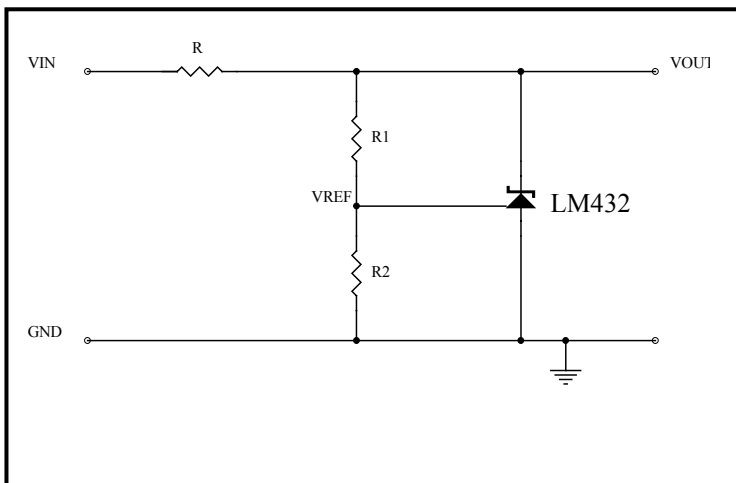

Notes:

- 1) Set V_{OUT} according to the following equation:

$$V_{OUT} = V_{REF}(1 + R1/R2) + I_{REF}R1$$
- 2) Choose the value for R as follows:
 - The maximum limit for R should be such that the cathode current, I_z , is greater than the minimum operating current($80\ \mu\text{A}$) at $V_{IN(MIN)}$.
 - The minimum limit for R should be as such that I_z does not exceed 100mA under all load conditions, and the instantaneous turn-on value for I_z does not exceed 150mA. Both of the following conditions must be met:

$$R_{min} \geq V_{IN(max)}/150\text{mA}$$
 (to limit instantaneous turn-on I_z)

$$R_{min} \geq \frac{V_{IN(max)} - V_{OUT}}{I_{OUT(min)} + 100\text{mA}}$$
 (to limit I_z under normal operating conditions)



Absolute Maximum Ratings

Parameter	Symbol	Maximum	Units
Cathode Voltage	V _Z	20	V
Continuous Cathode Current	I _Z	100	mA
Reference Input Current	I _{REF}	3	mA
Power Dissipation at T _A =25°C			
SOT-23	P _D	0.37	W
TO-92		0.95	
Thermal Resistance			
SOT-23	Θ _{JA}	336	°C/W
TO-92		132	
Operating Ambient Temperature Range	T _A	0 to +70	°C
Operating Junction Temperature Range	T _J	0 to +150	°C
Storage Temperature Range	T _{stg}	-65 to +150	°C
Lead Temperature(Soldering) 10 seconds	T _{LEAD}	300	°C
ESD Rating(Human Body Model)	V _{ESD}	2	kV

Electrical Characteristics

Unless otherwise specified, T_A=25°C. Values in bold apply over full operating ambient temperature range.

Parameter	Symbol	Condition	LM432D			LM432C			Unit
			Min	Typ	Max	Min	Typ	Max	
Reference Voltage	V _{REF}	V _Z =V _{REF} , I _Z =10mA(Note 1)	1.237 1.224	1.240	1.243 1.256	1.234 1.222	1.240	1.246 1.258	V
V _{REF} Temperature Deviation	V _{DEV}	V _Z =V _{REF} , I _Z =10mA(Note 1)	-	10	25	-	10	25	mV
Ratio of Change in V _{REF} to change in V _Z	$\frac{\Delta V_{REF}}{\Delta V_Z}$	I _Z =10mA, ΔV _Z =16V to V _{REF}	-	-1.0	-2.7	-	-1.0	-2.7	mV/V
Reference Input Current	I _{REF}	R1=10kΩ, R2=∞, I _Z =10mA(Note2)	-	0.15	0.5	-	0.15	0.5	μA
I _{REF} Temperature Deviation	I _{REF(DEV)}	R1=10kΩ, R2=∞, I _Z =10mA(Note 2)	-	0.1	0.4	-	0.1	0.4	μA
Off-state Cathode Current	I _{Z(OFF)}	V _{REF} =0V, V _Z =6V(Note 3)	-	0.125	0.150	-	0.125	0.150	μA
		V _{REF} =0V, V _Z =16V(Note 3)	-	0.135	0.150	-	0.135	0.150	μA
Dynamic Output Impedance	r _Z	f < 1kHz, V _Z =V _{REF} I _Z =100 μA to 100mA(Note 1)	-	0.05	0.15	-	0.05	0.15	Ω
Minimum Operating Current	I _{Z(MIN)}	V _Z =V _{REF} (Note 1)	-	20	80	-	20	80	μA

Electrical Characteristics(Cont.)

Unless otherwise specified, TA=25°C. Values in bold apply over full operating ambient temperature range.

Parameter	Symbol	Condition	LM432B			LM432A			Unit
			Min	Typ	Max	Min	Typ	Max	
Reference Voltage	V _{REF}	V _Z =V _{REF} , I _Z =10mA(Note 1)	1.228 1.215	1.240	1.252 1.265	1.215 1.200	1.240	1.265 1.280	V
V _{REF} Temperature Deviation	V _{DEV}	V _Z =V _{REF} , I _Z =10mA(Note 1)	-	10	25	-	10	35	mV
Ratio of Change in V _{REF} to change in V _Z	$\frac{\Delta V_{REF}}{\Delta V_Z}$	I _Z =10mA, ΔV _Z =16V to V _{REF}	-	-1.0	-2.7	-	-1.0	-2.7	mV/V
Reference Input Current	I _{REF}	R1=10kΩ, R2=∞, I _Z =10mA(Note2)	-	0.15	0.5	-	0.15	0.5	μA
I _{REF} Temperature Deviation	I _{REF(DEV)}	R1=10kΩ, R2=∞, I _Z =10mA(Note 2)	-	0.1	0.4	-	0.1	0.4	μA
Off-state Cathode Current	I _{Z(OFF)}	V _{REF} =0V, V _Z =6V(Note 3)	-	0.125	0.150	-	0.125	0.150	μA
		V _{REF} =0V, V _Z =16V(Note 3)	-	0.135	0.150	-	0.135	0.150	μA
Dynamic Output Impedance	r _Z	f<1kHz, V _Z =V _{REF} I _Z =100 μA to 100mA(Note 1)	-	0.05	0.15	-	0.05	0.15	Ω
Minimum Operating Current	I _{Z(MIN)}	V _Z =V _{REF} (Note 1)	-	20	80	-	20	80	μA

Notes:

- (1) See Test Circuit 1.
- (2) See Test Circuit 2.
- (3) See Test Circuit 3.

Recommended Operating Conditions

	Symbol	Min	Max	Unit
Cathode Voltage	V _Z	V _{REF}	16	V
Cathode Current	I _Z	0.08	100	mA

Test Circuits

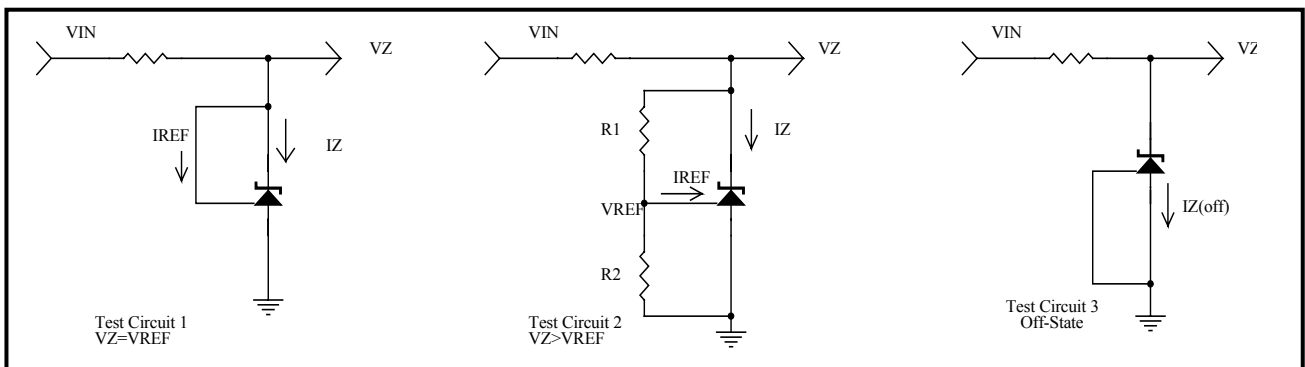

Pin Configurations

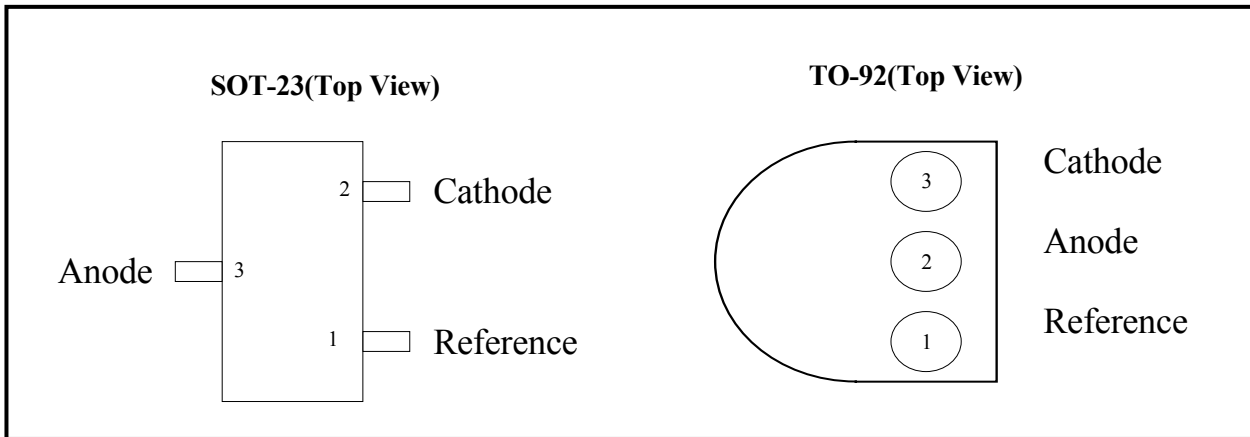

Block Diagram

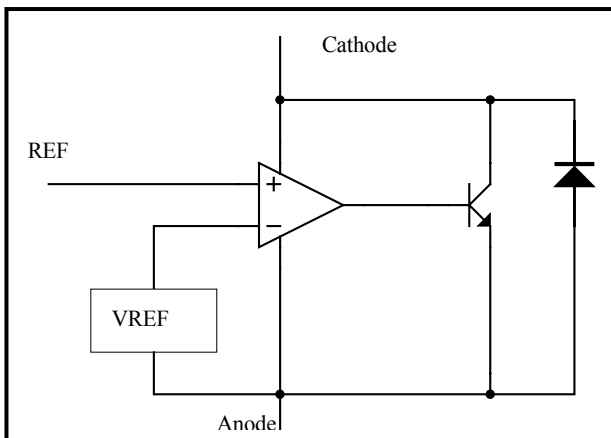

Symbol

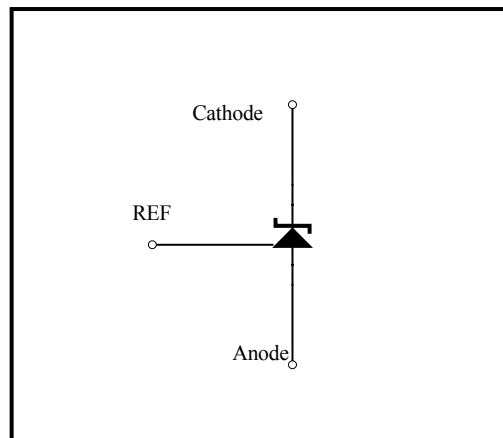

Ordering Information

Package	Tolerance			
	0.25%	0.5%	1%	2%
TO-92	LM432DA3	LM432CA3	LM432BA3	LM432AA3
SOT-23	LM432DN3	LM432CN3	LM432BN3	LM432AN3

Characteristic Curves



Cathode Current vs Cathode Voltage

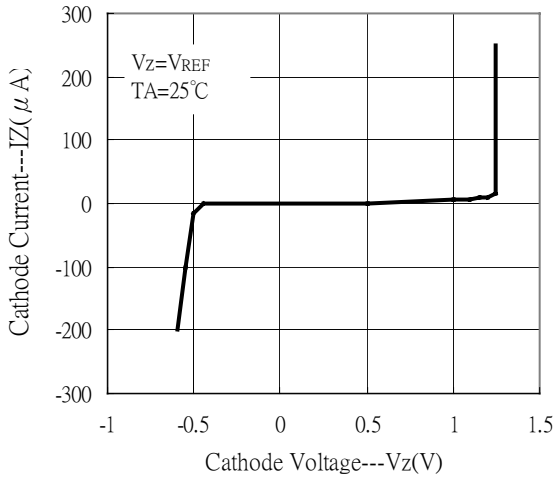

Cathode Current vs Cathode Voltage

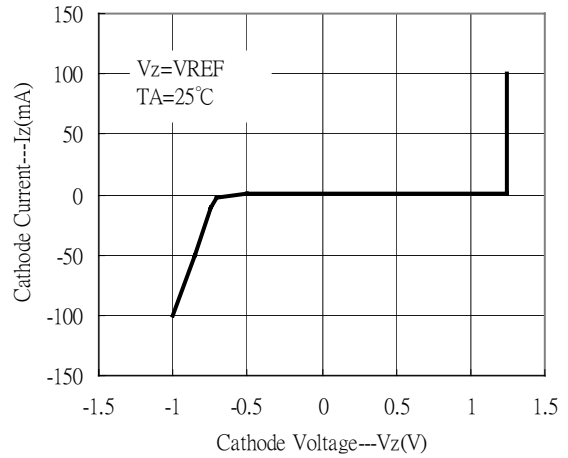

Reference Voltage vs Junction Temperature

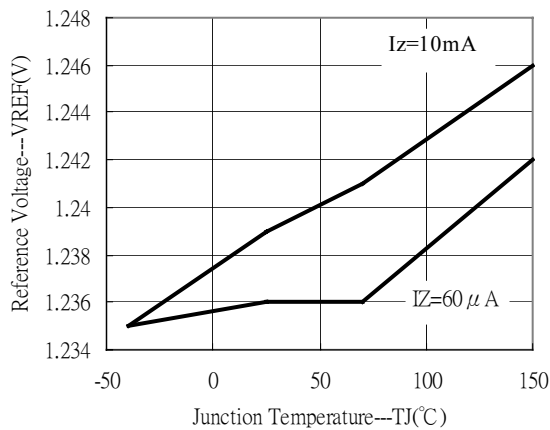

Reference Input Current vs Junction Temperature

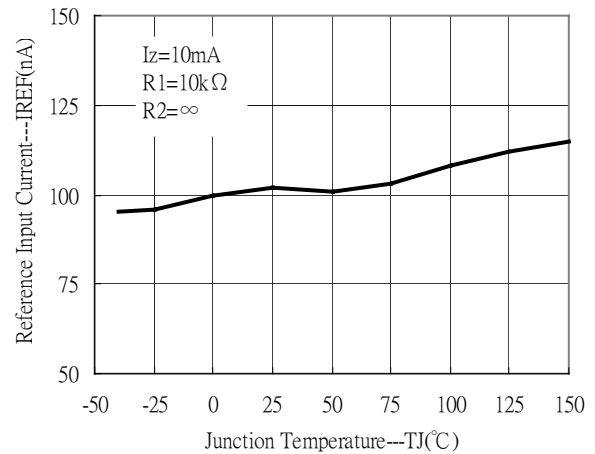

Ratio of Delta Reference Voltage to Delta Cathode Voltage vs Junction Temperature

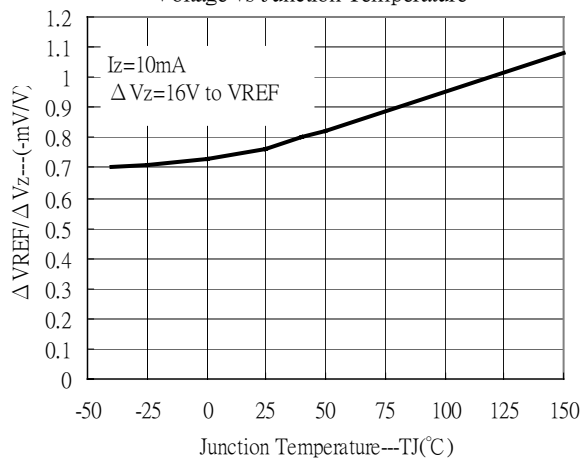

Off-State Cathode Current vs Junction Temperature

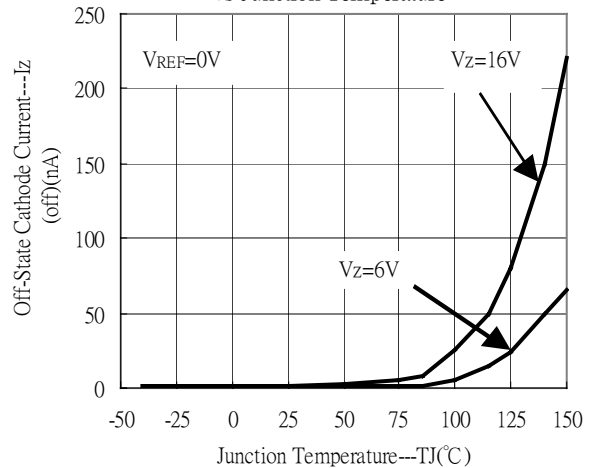

Reference Impedance vs Junction Temperature

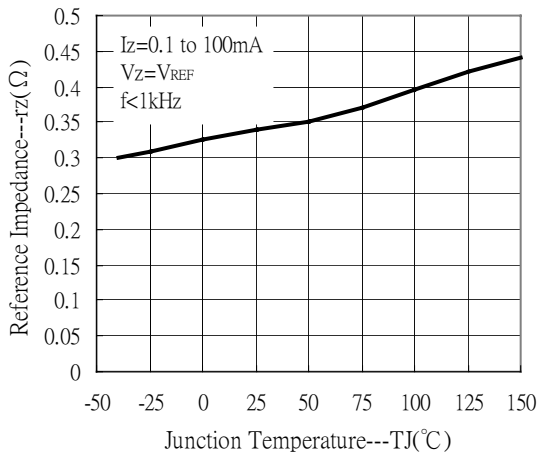

Reference Impedance vs Frequency

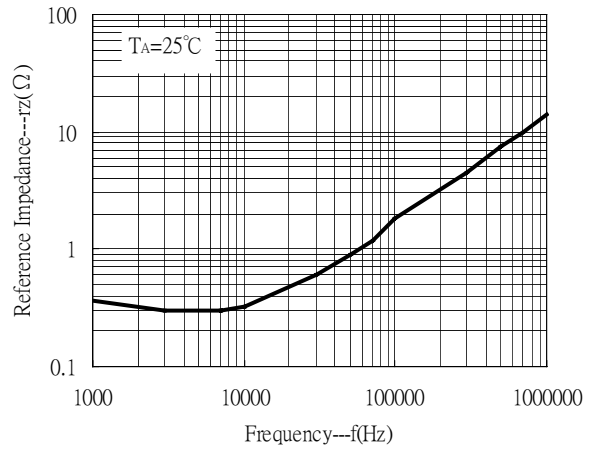

Small-Signal Gain vs Frequency

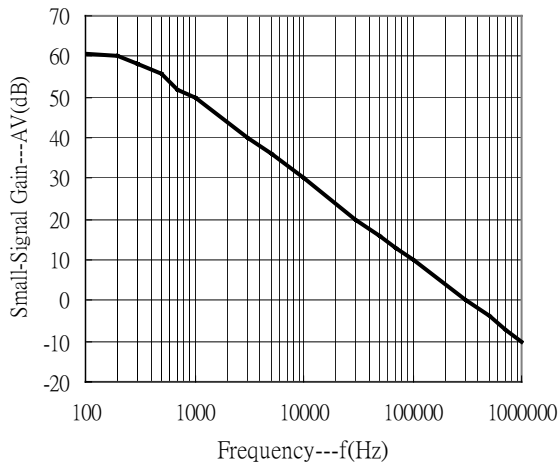

Small-Signal Phase Shift vs Frequency

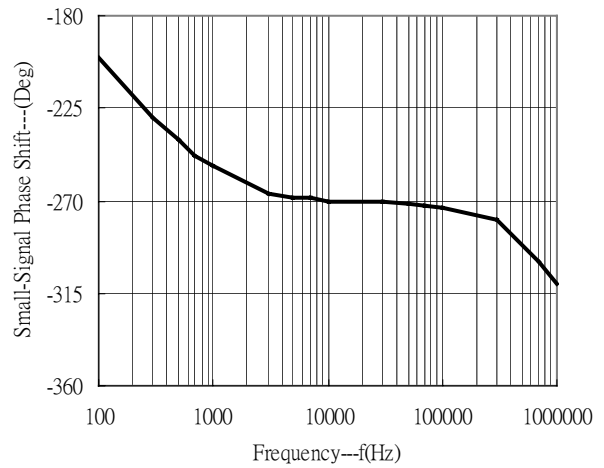

Stability Boundary Condition For Shunt Regulation vs Cathode Current and Load Capacitance

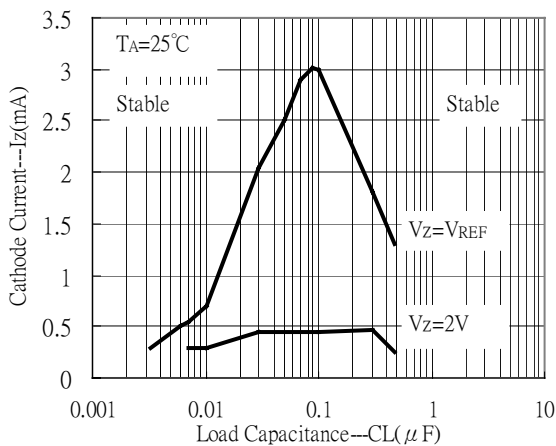

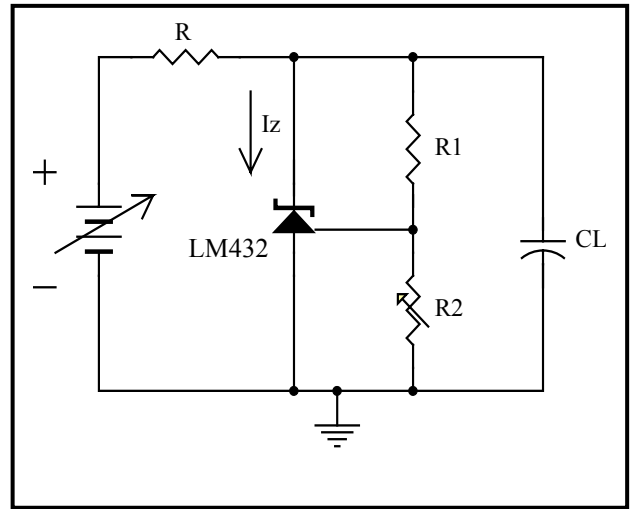
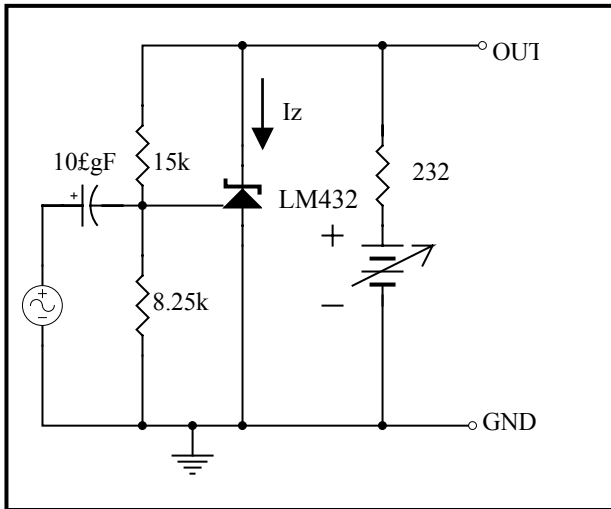

Applications Information - Stability

Selection of load capacitance when using LM432 as a shunt regulator

When the LM432 is used as a shunt regulator, two options for selection of C_L (see diagram on page 6) are recommended for optimal stability:

- 1) No load capacitance across the device, decouple at the load.
- 2) Large capacitance across the device, optimal decoupling at the load.

The reason for this is that LM432 exhibits instability with capacitances in the range of 10nF to 1 µF (approx.) at light cathode currents (up to 3mA typical). The device is less stable the lower the cathode voltage has been set for. Therefore while the device will be perfectly stable operating at a cathode current of (say) 10mA with a 0.1 µF capacitor across it, it will oscillate transiently during start-up as the cathode current passes through the instability region. Selecting a very low (or preferably, no) capacitance, or alternatively a high capacitance (such as 10 µF) will avoid this issue altogether. Since the user will probably wish to have local decoupling at the load anyway, the most cost effective method is to use no capacitance at all directly across the device. PCB trace/via resistance and inductance prevent the local load decoupling from causing the oscillation during the transient start-up phase.

Note : if the LM432 is located right at the load, so the load decoupling capacitor is directly across it, then this capacitor will have to be $\leq 1\text{nF}$ or $\geq 10\ \mu\text{F}$.

TO-92 Dimension

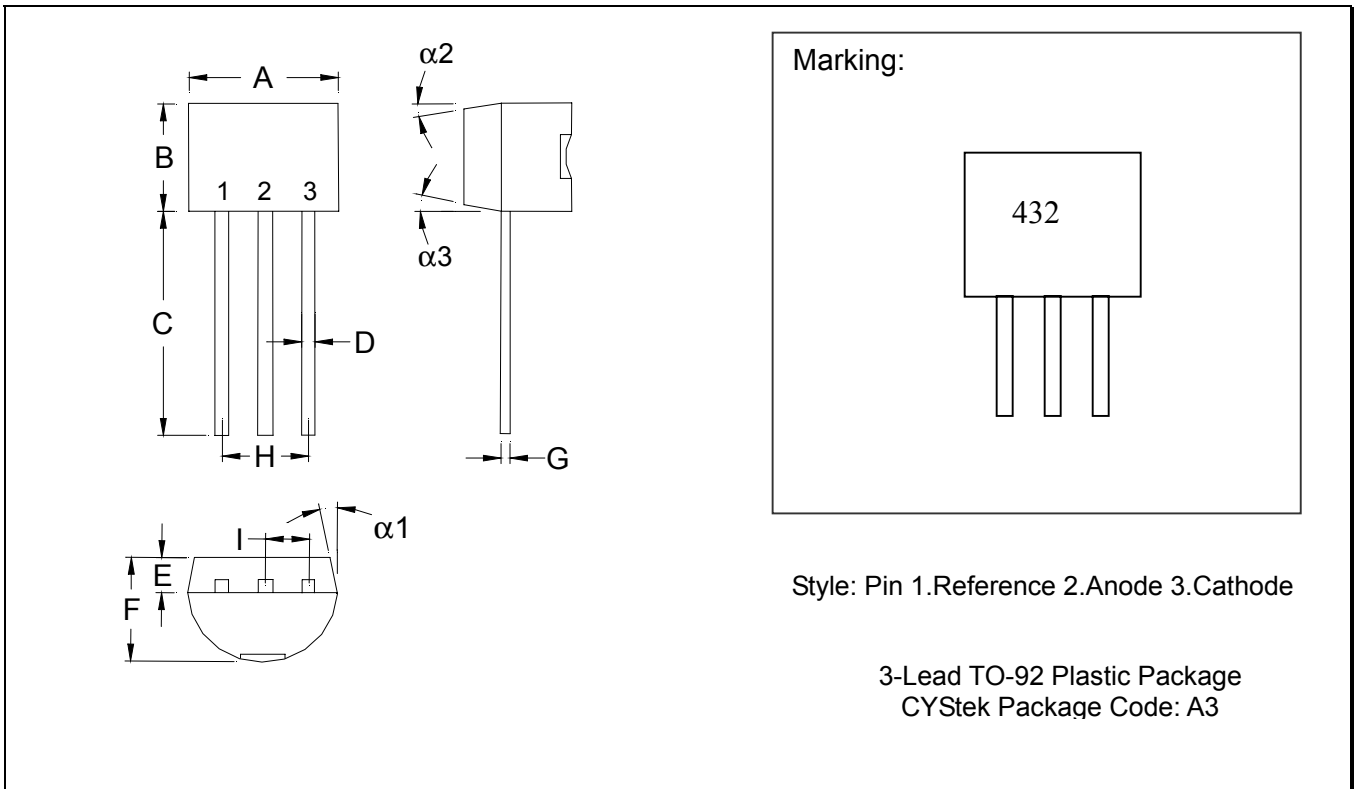

*: Typical

DIM	Inches		Millimeters		DIM	Inches		Millimeters	
	Min.	Max.	Min.	Max.		Min.	Max.	Min.	Max.
A	0.1704	0.1902	4.33	4.83	G	0.0142	0.0220	0.36	0.56
B	0.1704	0.1902	4.33	4.83	H	-	*0.1000	-	*2.54
C	0.5000	-	12.70	-	I	-	*0.0500	-	*1.27
D	0.0142	0.0220	0.36	0.56	$\alpha 1$	-	*5°	-	*5°
E	-	*0.0500	-	*1.27	$\alpha 2$	-	*2°	-	*2°
F	0.1323	0.1480	3.36	3.76	$\alpha 3$	-	*2°	-	*2°

Notes: 1.Controlling dimension: millimeters.
 2.Maximum lead thickness includes lead finish thickness, and minimum lead thickness is the minimum thickness of base material.
 3.If there is any question with packing specification or packing method, please contact your local CYStek sales office.

Material:

- Lead: 42 Alloy ; solder plating
- Mold Compound: Epoxy resin family, flammability solid burning class: UL94V-0

SOT-23 Dimension

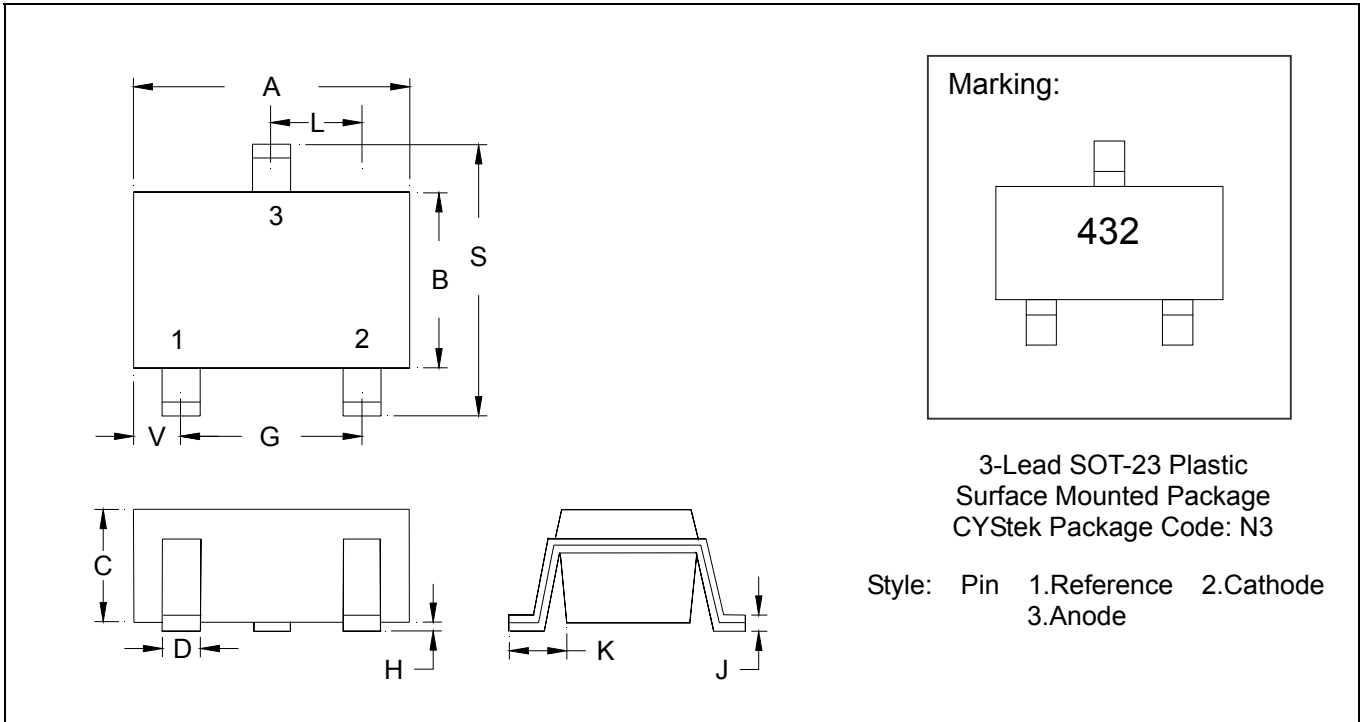

*: Typical

DIM	Inches		Millimeters		DIM	Inches		Millimeters	
	Min.	Max.	Min.	Max.		Min.	Max.	Min.	Max.
A	0.1102	0.1204	2.80	3.04	J	0.0034	0.0070	0.085	0.177
B	0.0472	0.0630	1.20	1.60	K	0.0128	0.0266	0.32	0.67
C	0.0335	0.0512	0.89	1.30	L	0.0335	0.0453	0.85	1.15
D	0.0118	0.0197	0.30	0.50	S	0.0830	0.1083	2.10	2.75
G	0.0669	0.0910	1.70	2.30	V	0.0098	0.0256	0.25	0.65
H	0.0005	0.0040	0.013	0.10					

Notes: 1.Controlling dimension: millimeters.
 2.Maximum lead thickness includes lead finish thickness, and minimum lead thickness is the minimum thickness of base material.
 3.If there is any question with packing specification or packing method, please contact your local CYCtek sales office.

Material:

- Lead: 42 Alloy; solder plating
- Mold Compound: Epoxy resin family, flammability solid burning class: UL94V-0

Important Notice:

- All rights are reserved. Reproduction in whole or in part is prohibited without the prior written approval of CYStek.
- CYStek reserves the right to make changes to its products without notice.
- CYStek **semiconductor products are not warranted to be suitable for use in Life-Support Applications, or systems.**
- CYStek assumes no liability for any consequence of customer product design, infringement of patents, or application assistance.