



VINCULUM

BINDING USB TECHNOLOGIES

Future Technology Devices International Ltd.

Vinculo Development Module

Datasheet

The Vinculo module is a Vinculum based development platform inspired by Arduino projects.

Document Reference No.: FT_000327

Version 1.0

Issue Date: 2010-10-13

Future Technology Devices International Ltd (FTDI)

Unit 1, 2 Seaward Place, Centurion Business Park, Glasgow, G41 1HH, United Kingdom

Tel.: +44 (0) 141 429 2777 Fax: + 44 (0) 141 429 2758

E-Mail (Support): support1@ftdichip.com

Web: <http://www.vinculum.com>

Neither the whole nor any part of the information contained in, or the product described in this manual, may be adapted or reproduced in any material or electronic form without the prior written consent of the copyright holder. This product and its documentation are supplied on an as-is basis and no warranty as to their suitability for any particular purpose is either made or implied. Future Technology Devices International Ltd will not accept any claim for damages howsoever arising as a result of use or failure of this product. Your statutory rights are not affected. This product or any variant of it is not intended for use in any medical appliance, device or system in which the failure of the product might reasonably be expected to result in personal injury. This document provides preliminary information that may be subject to change without notice. No freedom to use patents or other intellectual property rights is implied by the publication of this document. Future Technology Devices International Ltd, Unit 1, 2 Seaward Place, Centurion Business Park, Glasgow, G41 1HH, United Kingdom. Scotland Registered Number: SC136640

1 Introduction

Vinculo is a development module based on the FTDI Vinculum II, VNC2 dual USB host/slave IC. Vinculo is designed as a prototyping platform for VNC2 based designs and applications.

The mechanical form of the module, and the concept of providing free software development library and tools, is inspired by the Arduino concept. Vinculo is a superset of the Duemilanove / Uno with 2 extra rows of headers providing an extra 10 pins.

The software development environment, Vinculum-II IDE, uses a subset of standard ANSI 'C' instead of the Arduino Programming Language (wiring and processing) based software platform.

Vinculo may also be used with many existing Arduino shields by porting the firmware to run on the VNC2 IC.

The module uses a VNC2-64Q package to facilitate 38 GPIO options on 0.1" pitch header pins. A 10 bit A/D converter has also been added to offer connectivity to analogue inputs. This A/D converter can be read by the VNC2-64Q SPI host interface.

For USB connectivity the module includes one USB type A connector for a USB host port and one mini-B connector for a USB slave port to provide access to the VNC2-64Q USB ports.

An additional connector, to mate with the VII Debugger module, (also available from FTDI) is provided to connect to the VNC2 IDE (Integrated Development Environment) for creating and debugging application code to run on the Vinculo module.

The Vinculum-II IDE comes with a variety of pre-compiled driver libraries for fast prototyping different modules including support for a variety of USB classes such as Mass Storage, Human Interface Devices (keyboards, mice), audio devices, video devices (webcam) and many more still under development.

The development module will also be provided with a suite of libraries to facilitate fast application development.

A bare prototyping Vinculo PCB (Vinculo_Proto) which has the same PCB form factor as the Vinculo is also available. This can be used to prototype most shield application, comes with a selection of components and mates directly to the Vinculo connectors in a style similar to Arduino shields.

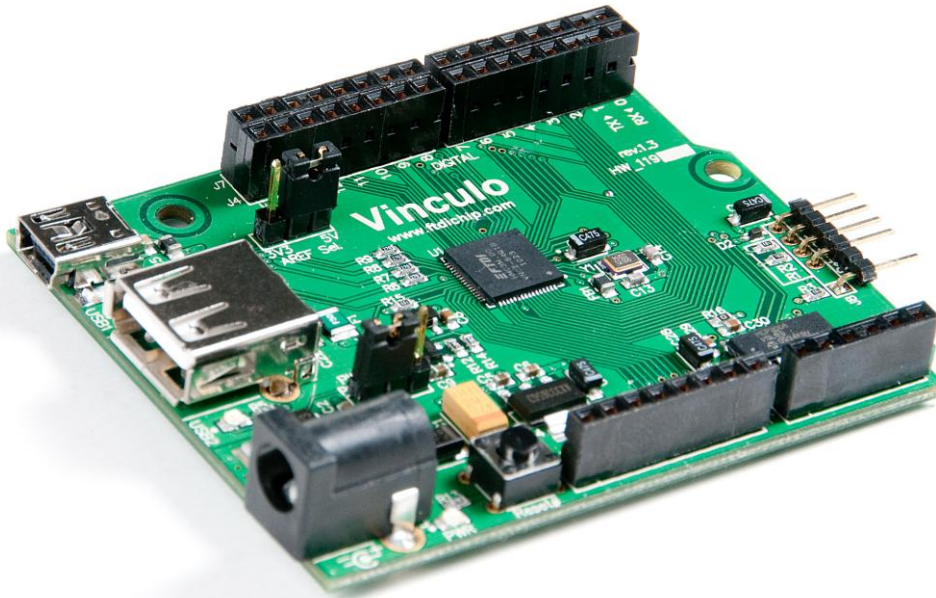

Figure 1.1 – VINCULO

1.1 Key Features

The Vinculo incorporates the following features:

- Microcontroller: VNC2-64Q
- Operating voltage: 5V
- Input power supply: 9V
- Digital I/O: 30
- Analogue I/O: 8
- USB port: 2 – configurable for host or device operation
- FLASH memory: 256kbytes
- RAM: 16kbytes
- Variable clock speeds: 12/24/48MHz
- Superset of the Arduino Duemilanove / Uno development boards.
- FTDI Integrated Development Environment (IDE) including code editor, compiler, assembler and debugger, which is supplied free of charge, and supports ANSII C coding for easy portability and maintainability.
- Precompiled drivers for a variety of interfaces e.g. USB, UART, SPI.
- Precompiled driver support for a wide range of USB host classes including Mass Storage, Human Interface Devices (keyboards, mice), audio devices, video devices (webcam) with many more under developed.
- Precompiled driver support for a wide range of USB device classes including FTDI peripheral ICs, Human Interface Devices (keyboards, mice) with many more under developed.
- Compatible with existing Arduino shields.
- A software configuration wizard is currently under development.

1.2 VNC2 IC

VNC2 is the second of FTDI's Vinculum family of Embedded dual USB host controller devices. VNC2 device provides USB Host interfacing capability for a variety of different USB device classes including support for BOMS (bulk only mass storage), Printer, HID (human interface devices). For mass storage devices such as USB Flash drives, VNC2 also transparently handles the FAT file structure.

Communication with non USB devices such as a low cost microcontroller is accomplished via either UART, SPI or parallel FIFO interfaces. VNC2 provides a new cost effective solution for providing USB Host capability into products that previously did not have the hardware resources available.

VNC2 has the capability to enable customers to develop custom firmware using the Vinculum II development software tool suite. The development tools support compiler, assembler, linker and debugger tools complete within an integrated development environment (IDE).

The Vinculum-II family of devices are available in Pb-free (RoHS compliant) 32-lead LQFP, 32-lead QFN, 48-lead LQFP, 48-lead QFN, 64-Lead LQFP and 64-lead QFN packages For more information on the ICs refer to <http://www.ftdichip.com/Products/ICs/VNC2.htm>

1.3 Part Numbers

Part Number	Description
VNCLO - MB1A	Vinculo Motherboard
VNCLO-PSU-US	Vinculo +9V/1A PSU (Optional) - USA
VNCLO-PSU-EU	Vinculo +9V/1A PSU (Optional) - Europe
VNCLO-PSU-UK	Vinculo +9V/1A PSU (Optional) - UK
VNCLO-SHLD1A	Vinculo_Proto prototyping shield (Optional)
VNC2 DEBUG MODULE	VNC2 debugger module
USB "A" to Mini-"B" Cable, 1m	USB "A" to Mini-"B" Cable, 1m

Table of Contents

1	Introduction	1
1.1	Key Features	2
1.2	VNC2 IC	2
1.3	Part Numbers.....	3
2	Functionality	3
2.1	Power	3
2.2	Input/Output.....	3
2.3	LEDs.....	3
3	Pin Out and Signal Description	4
3.1	Module Connector Descriptions.....	4
3.2	Vinculo Connectors : Pins and Signal Description.....	5
3.3	USB Slave Port : Pins and Signal Description	7
3.4	USB Host Port : Pins and Signal Description.....	7
3.5	Configuration Jumpers.....	8
4	Configurable Pin outs	9
4.1	UART Interface	9
4.1.1	Signal Description – UART Interface.....	9
4.2	Serial Peripheral Interface (SPI)	10
4.2.1	Signal Description - SPI Slave	10
4.2.2	Signal Description - SPI Master	10
4.3	Parallel FIFO Interface - Asynchronous Mode	11
4.3.1	Signal Description - Parallel FIFO Interface	11
5	Debugger Interface	12
5.1	Signal Description - Debugger Interface	12
6	ADC Converter.....	13
7	Firmware.....	14
7.1	Firmware Support	14
7.2	Available Firmware	14
7.3	Firmware Upgrades.....	14
7.4	Arduino Shield Compatible Firmware	14
8	Mechanical Dimensions	15
9	Schematic Diagram	16

10 Arduino Shields	17
11 Contact Information	18
Appendix A – References	19
Appendix B – List of Figures and Tables	20
List of Figures	20
List of Tables	20
Appendix C – Revision History	21

2 Functionality

2.1 Power

The Vinculo requires +5V for the USB host ports to power USB devices from the module. This is further regulated to +3.3V for VNC2.

A +9V/1A DC supply is also available which can be used as an AC-DC adapter (wall-wart). The +9V is regulated to +5V and +3V3 on the Vinculo module.

As an alternative to the AC-DC adapter the on board regulators can be taken out of circuit with jumpers to allow the +5V from a USB host port to power the module. Care should be taken with this approach as a USB host port can only provide a maximum of 500mA, which must power the Vinculo and potentially any devices connected to the Vinculo.

The +5V and +3V3 supplies may also be accessed on the J1 header pins.

VNC2 requires between 8 and 24mA depending on the clock speed at which the VNC2 core is running.

2.2 Input/Output

Due to the flexibility of the VNC2 IC the actual definition of each pin is not fixed. The firmware developed for any application can use the VNC2 IO Mux to route a signal, e.g. UART TXD, to a range of IO pins. An IOMux utility built into the free tool chain development environment, IDE, allows the developer to define the IO from a GUI interface. The utility will then convert the users IO selection into C code to be included as part of the project firmware...

There are 38 configurable IO pins available to the user, 8 of which are reserved for connecting to the onboard ADC device. The other 30 pins may be used for GPIO, UART, SPI or FIFO connectivity depending on the interface of the shield designed to connect to the Vinculo module.

There are 2 USB ports on the Vinculo. The firmware will determine if the port is configured for USB host operation or USB device operation.

2.3 LEDs

There are 3 LEDs on Vinculo.

LED1 is driven by the VNC2-64Q IC depending on which firmware is loaded. It may be used to indicate traffic on the USB slave port connected via CN3.

LED2 is driven by the VNC2-64Q IC depending on which firmware is loaded. It may be used to indicate traffic on the USB host port connected via CN2.

LED3 is driven by the 3V3 supply connected to the VNC2-64Q IC. It will indicate when the Vinculo module is powered.

3 Pin Out and Signal Description

3.1 Module Connector Descriptions

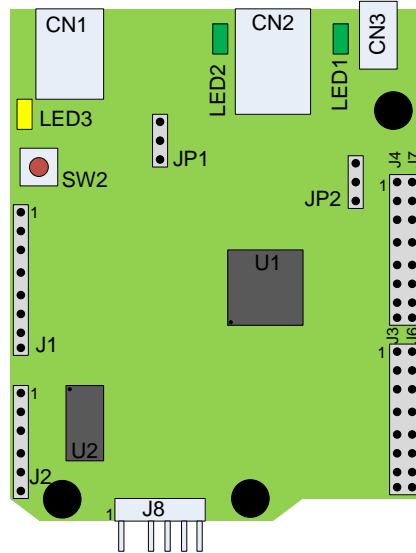

Figure 3.1 - Vinculo Diagram

A detailed description of each pin out is given in the next section.

CONNECTOR	FUNCTION
CN1	Power input
CN2	USB host port
CN3	USB slave port
J1	Interface to shield boards
J2	Interface to shield boards
J3	Interface to shield boards
J4	Interface to shield boards
J6	Interface to shield boards
J7	Interface to shield boards
J8	Debug port

3.2 Vinculo Connectors : Pins and Signal Description

Pin No.	Name	Pin Name on PCB	Type	Description
CN1	9V	PWR	PWR Input	9V module supply pin. This pin can be used to provide the 5.0V input to the Vinculo when the V2DIP2-64 is not powered from the USB connector (VBUS) or the debugger interface. Also connected to DIL connector pins J1-1 and J3-6.
CN2	USB	USB2	USB host port	Connects to VNC2-64Q USB port 2
CN3	USB	USB1	USB slave port	Connects to VNC2-64Q USB port 1
J1-1	AIN6	ADC6	Analogue Input	Analogue input to channel 6 of the ADC
J1-2	AIN7	ADC7	Analogue Input	Analogue input to channel 7 of the ADC
J1-3	RESET#	RESET#	Input	Reset for the VNC2-64Q
J1-4	VCC3V3	3V3	PWR Output	3V3 output for external circuitry
J1-5	VCC5V	5V	Power output	5V output for external circuitry
J1-6	GND	GND	GND	GND for PCB
J1-7	GND	GND	GND	GND for PCB
J1-8	VCCIN	VCCIN	PWR Input	Alternative input to CN1 for supply.
J2-1	AIN0	ADC0	Analogue Input	Analogue input to channel 0 of the ADC
J2-2	AIN1	ADC1	Analogue Input	Analogue input to channel 1 of the ADC
J2-3	AIN2	ADC2	Analogue Input	Analogue input to channel 2 of the ADC
J2-4	AIN3	ADC3	Analogue Input	Analogue input to channel 3 of the ADC
J2-5	AIN4	ADC4	Analogue Input	Analogue input to channel 4 of the ADC
J2-6	AIN5	ADC5	Analogue Input	Analogue input to channel 5 of the ADC
J3-1	IOBUS33	RXD	I/O	5V safe bidirectional data / control bus bit 33 - default to RXD
J3-2	IOBUS32	TXD	I/O	5V safe bidirectional data / control bus bit 33 - default to TXD
J3-3	IOBUS34	IO34	I/O	5V safe bidirectional data / control bus bit 34
J3-4	IOBUS35	IO35	I/O	5V safe bidirectional data / control bus bit 35
J3-5	IOBUS36	IO36	I/O	5V safe bidirectional data / control bus bit 36
J3-6	IOBUS37	IO37	I/O	5V safe bidirectional data / control bus bit 37
J3-7	IOBUS38	IO38	I/O	5V safe bidirectional data / control bus bit 38
J3-8	IOBUS39	IO39	I/O	5V safe bidirectional data / control bus bit 39
J4-1	IOBUS6	IO6	I/O	5V safe bidirectional data / control bus bit 6
J4-2	IOBUS7	IO7	I/O	5V safe bidirectional data / control bus bit 7
J4-3	SS	IO11	I/O	5V safe bidirectional data / control bus bit 34 - default to SPI Slave select
J4-4	MOSI	IO9	I/O	5V safe bidirectional data / control bus bit 35 - default to SPI MOSI. Also connectors to onboard ADC
J4-5	MISO	IO10	I/O	5V safe bidirectional data / control bus bit 36 - default to SPI MISO Also connectors to onboard ADC
J4-6	SCK	IO8	I/O	5V safe bidirectional data / control bus bit 37 - default to SPI SCK. Also connects to onboard ADC

Pin No.	Name	Pin Name on PCB	Type	Description
J4-7	GND	GND	GND	GND for PCB
J4-8	AREF	AREF	Analogue Input	Analogue input to provide reference voltage for ADC
J6-1	IOBUS41	IO41	I/O	5V safe bidirectional data / control bus bit 41
J6-2	IOBUS42	IO42	I/O	5V safe bidirectional data / control bus bit 42
J6-3	IOBUS43	IO43	I/O	5V safe bidirectional data / control bus bit 43
J6-4	IOBUS1	IO1	I/O	5V safe bidirectional data / control bus bit 1
J6-5	IOBUS2	IO2	I/O	5V safe bidirectional data / control bus bit 2
J6-6	IOBUS3	IO3	I/O	5V safe bidirectional data / control bus bit 3
J6-7	IOBUS4	IO4	I/O	5V safe bidirectional data / control bus bit 4
J6-8	IOBUS5	IO5	I/O	5V safe bidirectional data / control bus bit 5
J7-1	IOBUS12	IO12	I/O	5V safe bidirectional data / control bus bit 12
J7-2	IOBUS13	IO13	I/O	5V safe bidirectional data / control bus bit 13
J7-3	IOBUS14	IO14	I/O	5V safe bidirectional data / control bus bit 14
J7-4	IOBUS15	IO15	I/O	5V safe bidirectional data / control bus bit 15
J7-5	IOBUS16	IO16	I/O	5V safe bidirectional data / control bus bit 16
J7-6	IOBUS17	IO17	I/O	5V safe bidirectional data / control bus bit 17
J7-7	IOBUS18	IO18	I/O	5V safe bidirectional data / control bus bit 18
J7-8	IOBUS19	IO19	I/O	5V safe bidirectional data / control bus bit 19
J8-1	Debug I/F	Debug I/F	I/O	Interface to VNC2-64Q debugger pin
J8-2	NC		NV	Not connected – used as a key for VII Debugger
J8-3	GND	GND	GND	GND for PCB
J8-4	RESET#	RESET#	Input	Reset for the VNC2-64Q
J8-5	PROG#	PROG#	Input	Used to put the VNC2-64Q into PROGRAM mode if loading ROM file over UART
J8-6	VBUS	5V	PWR Input	May be used by debugger to power module

Table 3.1 - Pin Signal Descriptions

3.3 USB Slave Port : Pins and Signal Description

Connector CN3 is a USB mini-B, designed for connecting to USB hosts. This connector routes to the VNC2-64Q USB port 1 and the firmware on the VNC2-64Q should be written to ensure it is in slave mode.

The port is USB 2.0 full speed compliant.

This port can also be used to provide power to the Vinculo with 5V at 500mA max.

Pin No.	Signal
1	5V (can be used to power PCB or disabled with JP1)
2	USB DM
3	USB DP
4	Not connected
5	GND

Table 3.2 - USB Slave Pin Out

3.4 USB Host Port : Pins and Signal Description

Connector CN2 is a USB type A connector designed for connecting to USB devices. This connector routes to the VNC2-64Q USB port 2 and the firmware on the VNC2-64Q should be written to ensure it is in host mode.

The port is USB 2.0 full speed compliant.

Pin No.	Signal
1	5V supply to peripheral device. Enabled by the VNC2-64Q
2	USB DM
3	USB DP
4	GND

Table 3.3 - USB Slave Pin Out

3.5 Configuration Jumpers

There are two configuration jumper links on the Vinculo.

JP1 is used to select the Vinculo power source.

JP2 is used to select the reference voltage for the ADC (U2)

	1-2	2-3
JP1	Vinculo is Powered from USB host via CN3	Vinculo is Powered from external 9V supply
JP2	ADC reference voltage = 3V3	ADC reference voltage = 5V0

Table 3.4 – Jumper Options

4 Configurable Pin outs

4.1 UART Interface

When the Vinculo data and control buses are configured as a UART interface, the interface implements a standard asynchronous serial UART port with flow control. The UART can support baud rates from 300baud to 6Mbaud. The UART interface is described in more detail in the Vinculum-II datasheet please refer to: - [FTDI website](#)

4.1.1 Signal Description – UART Interface

The UART signals can be programmed to a choice of available I/O pins. **Table 4.1** explains the available pins for each of the UART signals. This is a subset of what the VNC2-64Q is capable of to avoid conflict with other functions on the Vinculo module.

<i>Available Pins</i>	<i>Name</i>	<i>Type</i>	<i>Description</i>
J3-2, J3-5, J6-7, J7-1, J7-5	uart_txd	Output	Transmit asynchronous data output (Default J3-2)
J3-1, J3-6, J6-1, J6-4, J6-8, J7-2, J7-6	uart_rxd	Input	Receive asynchronous data input (Default J3-1)
J3-3, J3-7, J4-1, J6-2, J6-5, J7-3, J7-7	uart_rts#	Output	Request To Send Control Output
J3-4, J3-8, J4-2, J6-3, J6-6, J7-4, J7-8	uart_cts#	Input	Clear To Send Control Input
J3-2, J3-5, J6-7, J7-1, J7-5	uart_dtr#	Output	Data Acknowledge (Data Terminal Ready Control) Output
J3-1, J3-6, J6-1, J6-4, J6-8, J7-2, J7-6	uart_dsr#	Input	Data Request (Data Set Ready Control) Input
J3-3, J3-7, J4-1, J6-2, J6-5, J7-3, J7-7	uart_dcd#	Input	Data Carrier Detect Control Input
J3-4, J3-8, J4-2, J6-3, J6-6, J7-4, J7-8	uart_ri#	Input	Ring Indicator Control Input. RI# low can be used to resume the PC USB Host controller from suspend.
J3-2, J3-5, J6-7, J7-1, J7-5	uart_tx_active	Output	Enable Transmit Data for RS485 designs. TXDEN may be used to signal that a transmit operation is in progress. The TXDEN signal will be set high one bit-time before data is transmitted and return low one bit time after the last bit of a data frame has been transmitted

Table 4.1 - Data and Control Bus Signal Mode Options – UART

Note: # defines active low signals.

4.2 Serial Peripheral Interface (SPI)

The VNC2-64Q has one master module and two slave modules. These modules are described more fully in a VNC2 datasheet please refer to: - [FTDI website](#)

4.2.1 Signal Description - SPI Slave

The SPI Slave signals can be programmed to a choice of available I/O pins. **Table 4.2** explains the available pins for each of the SPI Slave signals. This is a subset of what the VNC2-64Q is capable of to avoid conflict with other functions on the Vinculo module.

Available Pins	Name	Type	Description
J3-5, J6-7, J7-1, J7-5	spi_s0_clk spi_s1_clk	Input	Slave clock input
J3-6, J6-1, J6-4, J6-8, J7-2, J7-6	spi_s0_mosi spi_s1_mosi	Input/Output	Master Out Slave In Synchronous data from master to slave
J3-3, J3-7, J4-1, J6-2, J6-5, J7-3, J7-7	spi_s0_miso spi_s1_miso	Output	Master In Slave Out Synchronous data from slave to master
J3-4, J3-8, J4-2, J6-3, J6-6, J7-4, J7-8	spi_s0_ss# spi_s1_ss#	Input	Slave chip select

Table 4.2 - Data and Control Bus Signal Mode Options – SPI Slave

Note: # defines active low signals.

4.2.2 Signal Description - SPI Master

The SPI Master signals can be programmed to a choice of available I/O pins. **Table 4.3** shows the SPI master signals and the available pins that they can be mapped. This is a subset of what the VNC2-64Q is capable of to avoid conflict with other functions on the Vinculo module.

Available Pins	Name	Type	Description
J3-5, J4-6, J6-7, J7-1, J7-5	spi_m_clk	Output	SPI master clock input (J4-6 is the default)
J3-6, J4-4, J6-1, J6-4, J6-8, J7-2, J7-6	spi_m_mosi	Output	Master Out Slave In Synchronous data from master to slave (J4-4 is the default)
J3-3, J3-7, J4-1, J4-5, J6-2, J6-5, J7-3, J7-7	spi_m_miso	Input	Master In Slave Out Synchronous data from slave to master (J4-5 is the default)
J3-4, J3-8, J4-2, J4-3, J6-3, J6-6, J7-4, J7-8	spi_m_ss_0#	Output	Active low slave select 0 from master to slave 0 This SS# is used with the onboard ADC
3-5, J6-7, J7-1, J7-5	spi_m_ss_1#	Output	Active low slave select 1 from master to slave 1

Table 4.3 - Data and Control Bus Signal Mode Options – SPI Master

Note: # defines active low signals.

4.3 Parallel FIFO Interface - Asynchronous Mode

The Parallel FIFO Asynchronous mode is functionally the same as the Parallel FIFO Interface available in the FTDI VDIP1 module and has an eight bit data bus, individual read and write strobes and two hardware flow control signals.

4.3.1 Signal Description - Parallel FIFO Interface

The Parallel FIFO Interface signals can be programmed to a choice of available I/O pins. **Table 4.4** shows the Parallel FIFO Interface signals and the pins that they can be mapped. Details of the operation and timing can be found in the VNC2 datasheet.

Available Pins	Name	Type	Description
J3-5, J6-7, J7-1, J7-5	fifo_data[0]	I/O	FIFO data bus Bit 0
J3-6, J6-1, J6-4, J6-8, J7-2, J7-6	fifo_data[1]	I/O	FIFO data bus Bit 1
J3-3, J3-7, J4-1, J6-2, J6-5, J7-3, J7-7	fifo_data[2]	I/O	FIFO data bus Bit 2
J3-4, J3-8, J4-2, J6-3, J6-6, J7-4, J7-8	fifo_data[3]	I/O	FIFO data bus Bit 3
J3-5, J6-7, J7-1, J7-5	fifo_data[4]	I/O	FIFO data bus Bit 4
J3-6, J6-1, J6-4, J6-8, J7-2, J7-6	fifo_data[5]	I/O	FIFO data bus Bit 5
J3-3, J3-7, J4-1, J6-2, J6-5, J7-3, J7-7	fifo_data[6]	I/O	FIFO data bus Bit 6
J3-4, J3-8, J4-2, J6-3, J6-6, J7-4, J7-8	fifo_data[7]	I/O	FIFO data bus Bit 7
J3-5, J6-7, J7-1, J7-5	fifo_rxf#	Output	When high, do not read data from the FIFO. When low, there is data available in the FIFO which can be read by strobing RD# low, then high.
J3-6, J6-1, J6-4, J6-8, J7-2, J7-6	fifo_txe#	Output	When high, do not write data into the FIFO. When low, data can be written into the FIFO by strobing WR high, then low.
J3-3, J3-7, J4-1, J6-2, J6-5, J7-3, J7-7	fifo_rd#	Input	Enables the current FIFO data byte on D0...D7 when low. Fetches the next FIFO data byte (if available) from the receive FIFO buffer when RD# goes from high to low
J3-4, J3-8, J4-2, J6-3, J6-6, J7-4, J7-8	fifo_wr#	Input	Writes the data byte on the D0...D7 pins into the transmit FIFO buffer when WR goes from high to low.

Table 4.4 - Data and Control Bus Signal Mode Options – Parallel FIFO Interface

Note: # defines active low signals.

5 Debugger Interface

The purpose of the debugger interface, J8, is to provide access to the VNC2 silicon/firmware debugger. The debug interface can be accessed by connecting a *VNC2_Debug_Module* to the J8 connector. This debug module will give access to the debugger through a USB connection to a PC via the Integrated Development Environment (IDE). The IDE is accessed through a GUI to the VNC2 software development tool-chain and gives the following debug capabilities through the debugger interface:

- Flash Erase, Write and Program.
- Application debug - application code can have breakpoints, be single stepped and can be halted.
- Detailed internal debug - memory and register read/write access.

The IDE may be downloaded from <http://www.ftdichip.com/Firmware/V2TC/VNC2toolchain.htm>

The Debugger Interface, and how to use it, is further described in the following applications Note [Vinculum-II Debug Interface Description](#)

5.1 Signal Description - Debugger Interface

Table 5.1 shows the signals and pins description for the Debugger Interface pin header J8

<i>Pin No.</i>	<i>Name</i>	<i>Name On PCB</i>	<i>Type</i>	<i>Description</i>
J8-1	I00	DBG	I/O	Debugger Interface
J8-2	-	[Key]	-	Not connected. Used to make sure that the debug module is connected correctly.
J8-3	GND	GND	PWR	Module ground supply pin
J8-4	RESET#	RST#	Input	Can be used by an external device to reset the VNC2. This pin is also used in combination with PROG# and the UART interface to program firmware into the VNC2.
J8-5	PROG#	PRG#	Input	This pin is used in combination with the RESET# pin and the UART interface to program firmware into the VNC2.
J8-6	5V0	VCC	PWR Input	5.0V module supply pin. This pin can be used to provide the 5.0V input to the Vinculo from the debugger interface when the Vinculo is not powered from the USB connector (VBUs) or the CN1

Table 5.1 - Signal Name and Description – Debugger Interface

Note: # defines active low signals.

6 ADC Converter

The Vinculo module is fitted with a MCP3008, 8 channel analogue to digital converter (ADC) with SPI output.

The analogue inputs are tracked out to the header pins such that an external signal may be applied for the VNC2-64Q to read the values with its SPI master interface.

Alternatively the VNC2-64Q PWM interface may be used to provide waveforms for the ADC to convert and the VNC2-64Q can read the digital output over SPI in a loopback arrangement.

<i>Pin No.</i>	<i>VNC2-64Q Pin</i>	<i>Name On PCB</i>	<i>Type</i>	<i>Description</i>
J2-1	43	AIN0	Input	MCP3008 analogue input channel 0 / VNC2-64Q PWM0
J2-2	44	AIN1	Input	MCP3008 analogue input channel 1 / VNC2-64Q PWM1
J2-3	45	AIN2	Input	MCP3008 analogue input channel 2 / VNC2-64Q PWM2
J2-4	46	AIN3	Input	MCP3008 analogue input channel 3 / VNC2-64Q PWM3
J2-5	47	AIN4	Input	MCP3008 analogue input channel 4 / VNC2-64Q PWM4
J2-6	48	AIN5	Input	MCP3008 analogue input channel 5 / VNC2-64Q PWM5
J1-1	49	AIN6	Input	MCP3008 analogue input channel 6 / VNC2-64Q PWM6
J1-2	50	AIN7	Input	MCP3008 analogue input channel 7 / VNC2-64Q PWM7

Table 6.1 – ADC Interface

7 Firmware

7.1 Firmware Support

The VNC2-64Q on the Vinculo is provided with no firmware pre-loaded however it can be programmed with the customers own firmware created using the Vinculum II firmware development tool-chain or with various pre-compiled firmware profiles to allow a designer to easily change the functionality of the chip. Please refer to: - [FTDI website](#) for full details on available pre-compiled firmware

7.2 Available Firmware

Please refer to: - [FTDI website](#) for full details.

7.3 Firmware Upgrades

Refer to the debugger interface section 6 which can be used to update the firmware.

7.4 Arduino Shield Compatible Firmware

As the mechanical form factor and pin out is inspired by the Arduino Duemilanove module, many Arduino shields are compatible with the Vinculo module. Libraries and example applications will be made available allowing the Vinculo to be used in association with stepper motors, GSM modules, LCD displays and many other applications. Additionally with the IDE it will be possible for users to develop new shields and applications.

8 Mechanical Dimensions

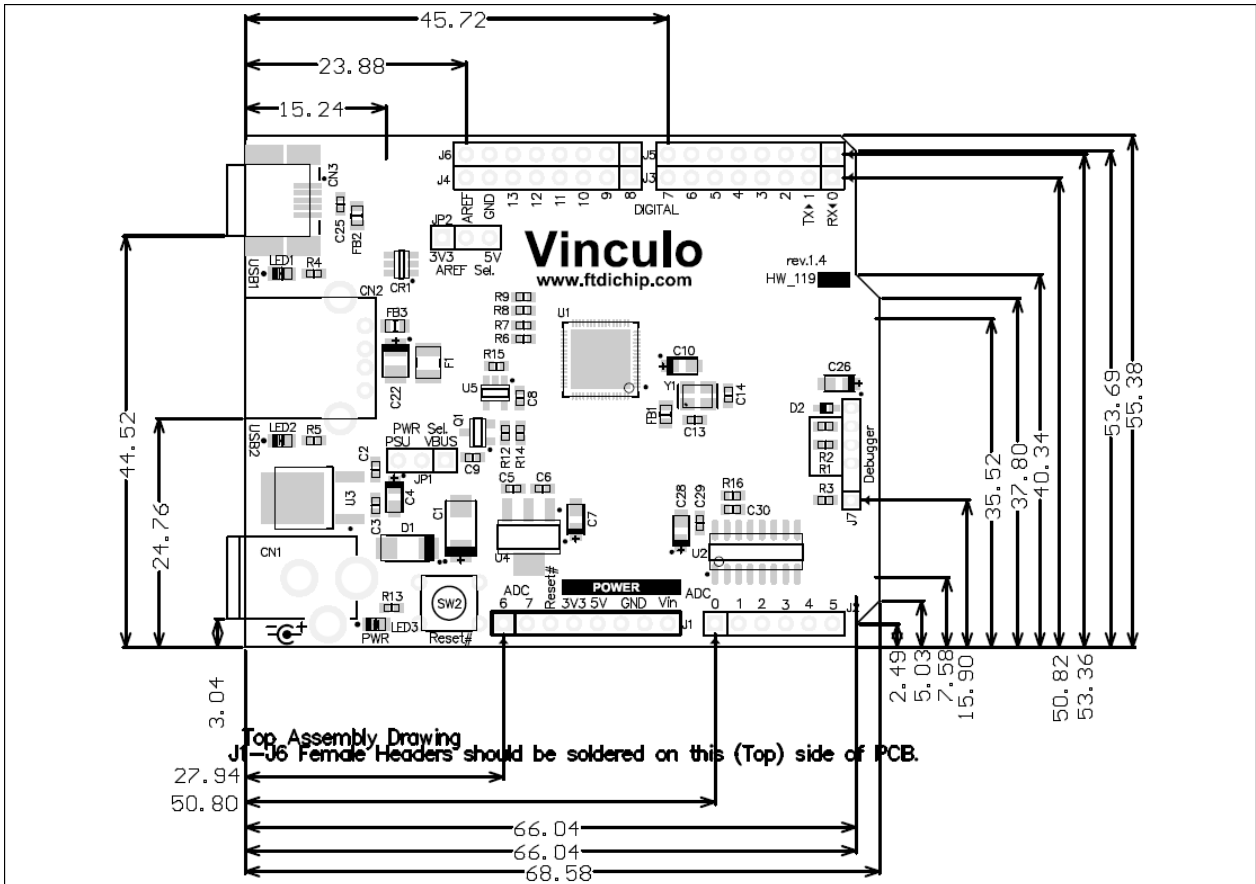

Figure 8.1 - Vinculo Dimensions

±0.20mm Tolerance (except pitch)
 Maximum height is 15mm
 All dimensions are in mm

9 Schematic Diagram

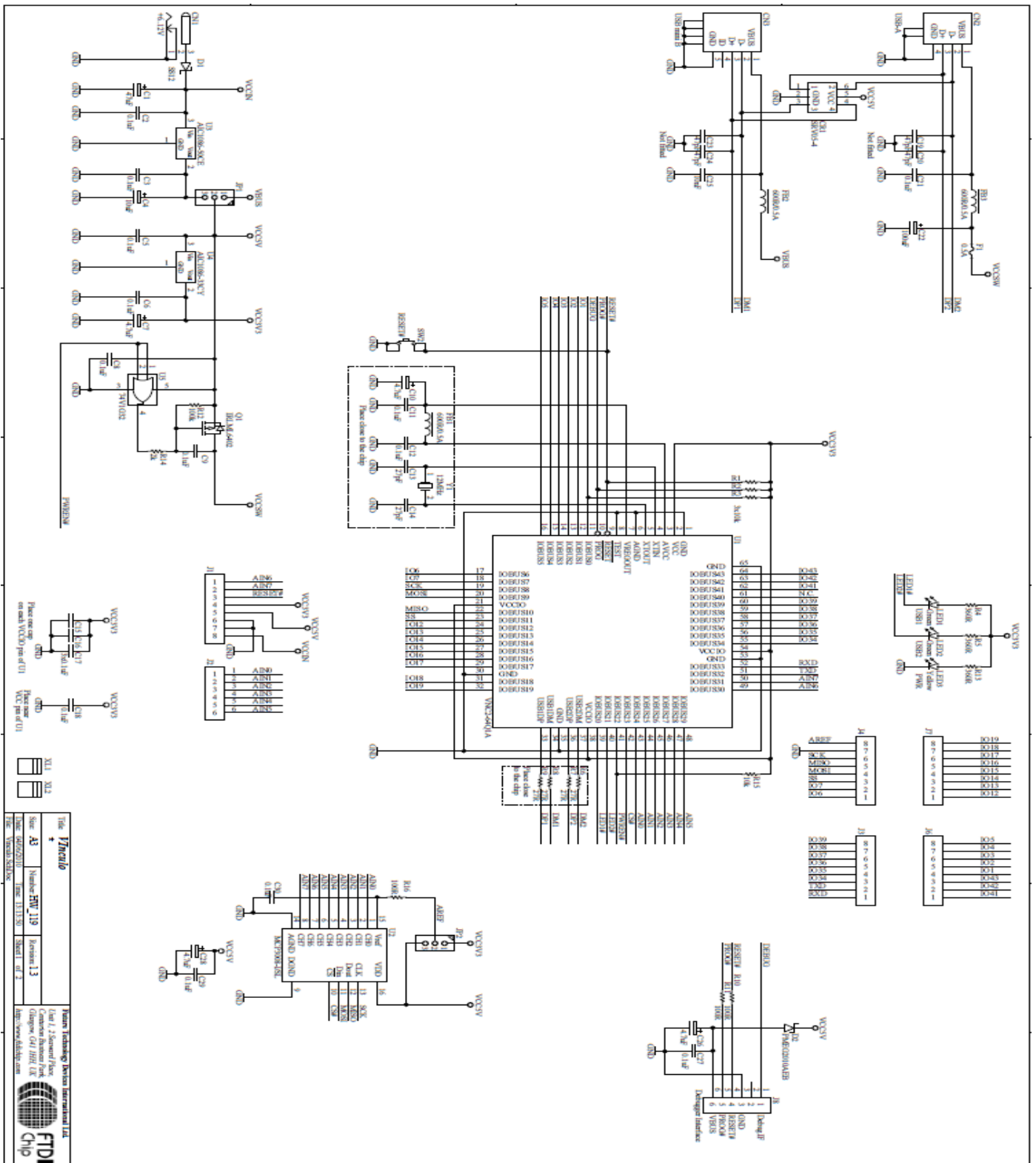

Figure 9.1 - Vinculo Schematics

10 Arduino Shields

The Vinculo module has the same form factor as the Arduino Duemilanove under the terms of the Creative Commons Attribution Share-Alike license, which allows for both personal and commercial derivative works.

This allows for other Arduino compatible shields to mate directly to the Vinculo PCB.

In addition to the existing shields on the market, a bare shield with a prototyping area, Vinculo_Proto, is also available to enable users to make their own shield. This shield includes connectors and an assortment of resistors and LEDs to provide a starting point aimed at the hobbyist.

11 Contact Information

Head Office – Glasgow, UK

Future Technology Devices International Limited
Unit 1, 2 Seaward Place,
Centurion Business Park
Glasgow, G41 1HH
United Kingdom
Tel: +44 (0) 141 429 2777
Fax: +44 (0) 141 429 2758

E-mail (Sales) sales1@ftdichip.com
E-mail (Support) support1@ftdichip.com
E-mail (General Enquiries) admin1@ftdichip.com
Web Site URL <http://www.ftdichip.com>
Web Shop URL <http://www.ftdichip.com>

Branch Office – Taipei, Taiwan

Future Technology Devices International Limited (Taiwan)
2F, No 516, Sec. 1 NeiHu Road
Taipei 114
Taiwan, R.O.C.
Tel: +886 (0) 2 8791 3570
Fax: +886 (0) 2 8791 3576

E-mail (Sales) tw.sales1@ftdichip.com
E-mail (Support) tw.support1@ftdichip.com
E-mail (General Enquiries) tw.admin1@ftdichip.com
Web Site URL <http://www.ftdichip.com>

Branch Office – Hillsboro, Oregon, USA

Future Technology Devices International Limited (USA)
7235 NW Evergreen Parkway, Suite 600
Hillsboro, OR 97123-5803
USA
Tel: +1 (503) 547 0988
Fax: +1 (503) 547 0987

E-Mail (Sales) us.sales@ftdichip.com
E-Mail (Support) us.support@ftdichip.com
E-Mail (General Enquiries) us.admin@ftdichip.com
Web Site URL <http://www.ftdichip.com>

Branch Office – Shanghai, China

Future Technology Devices International Limited (China)
Room 408, 317 Xianxia Road,
ChangNing District,
ShangHai, China

Tel: +86 (21) 62351596
Fax: +86(21) 62351595

E-Mail (Sales): cn.sales@ftdichip.com
E-Mail (Support): cn.support@ftdichip.com
E-Mail (General Enquiries): cn.admin1@ftdichip.com
Web Site URL <http://www.ftdichip.com>

Distributor and Sales Representatives

Please visit the Sales Network page of the FTDI Web site for the contact details of our distributor(s) and sales representative(s) in your country.

Appendix A – References

[VNC2 Datasheet](#)

[Vinculum-II Errata Technical Note](#)

Application and Technical Notes available at
<http://www.ftdichip.com/Support/Documents/AppNotes.htm>

[Vinculum-II IO Cell Description](#)

[Vinculum-II Debug Interface Description](#)

[Vinculum-II IO Mux Explained](#)

[Vinculum-II PWM Example](#)

[Migrating Vinculum Designs From VNC1L to VNC2-48L1A](#)

[Vinculum-II Toolchain Installation Guide](#)

[Vinculum-II Toolchain Getting Started Guide](#)

[Vinculum-II User Guide](#)

[MCP3008 Datasheet](#)

(<http://ww1.microchip.com/downloads/en/DeviceDoc/21295d.pdf>)

Appendix B – List of Figures and Tables

List of Figures

Figure 1.1 – VINCULO	1
Figure 3.1 - Vinculo Diagram.....	4
Figure 8.1 - Vinculo Dimensions	15
Figure 9.1 - Vinculo Schematics.....	16

List of Tables

Table 3.1 - Pin Signal Descriptions	6
Table 3.2 - USB Slave Pin Out	7
Table 3.3 - USB Slave Pin Out	7
Table 3.4 – Jumper Options	8
Table 4.1 - Data and Control Bus Signal Mode Options – UART	9
Table 4.2 - Data and Control Bus Signal Mode Options – SPI Slave	10
Table 4.3 - Data and Control Bus Signal Mode Options – SPI Master	10
Table 4.4 - Data and Control Bus Signal Mode Options – Parallel FIFO Interface	11
Table 5.1 - Signal Name and Description – Debugger Interface	12
Table 6.1 – ADC Interface.....	13

Appendix C – Revision History

Version 1.0 First Release

October 13th 2010