

**PLEASE CHECK WWW.MOLEX.COM FOR LATEST PART INFORMATION**

**Part Number:** [0901190111](#)  
**Status:** **Active**  
**Overview:** [cgrid\\_iii](#)  
**Description:** C-Grid III™ Crimp Terminal, 22-24 AWG, Reel, 0.76µm (30µ") Selective Gold (Au)

**Documents:**

[3D Model](#) [RoHS Certificate of Compliance \(PDF\)](#)  
[Drawing \(PDF\)](#)

**General**

Product Family	Crimp Terminals
Series	<a href="#">90119</a>
Comments	Left-hand feed
Crimp Quality Equipment	Yes
Overview	<a href="#">cgrid_iii</a>
Product Name	C-Grid III™

**Physical**

Gender	Female
Material - Metal	Phosphor Bronze
Material - Plating Mating	Gold
Material - Plating Termination	Tin
Packaging Type	Reel
Plating min: Mating (µin)	30.4
Plating min: Mating (µm)	0.76
Plating min: Termination (µin)	120
Plating min: Termination (µm)	3
Termination Interface: Style	Crimp or Compression
Wire Insulation Diameter	1.02-1.47mm (.040-.058")
Wire Size AWG	22, 24
Wire Size mm²	N/A

**Material Info**

**Reference - Drawing Numbers**

Sales Drawing	SD-90119
---------------	----------

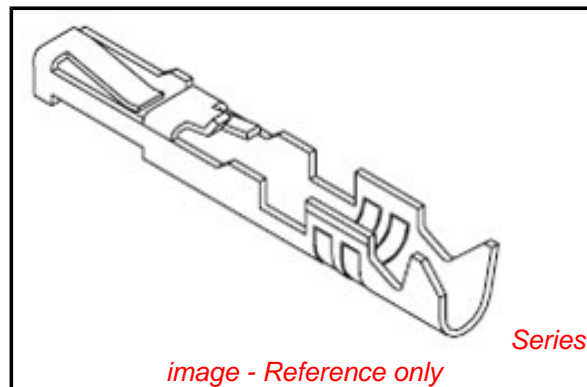

*image - Reference only*

**EU RoHS**

**ELV and RoHS Compliant**  
**REACH SVHC**  
**Contains SVHC: No**  
**Halogen-Free Status**

**China RoHS**



**Halogen-Free**

**Need more information on product environmental compliance?**

Email [productcompliance@molex.com](mailto:productcompliance@molex.com)  
 For a multiple part number RoHS Certificate of Compliance, [click here](#)

Please visit the [Contact Us](#) section for any non-product compliance questions.

**Search Parts in this Series**

[90119Series](#)

**Use With**

C-Grid III™ Modular Crimp Housing [90156](#) ,  
[90123](#) , [90142](#) , [90143](#) , [90160](#)

**Application Tooling | FAQ**

*Tooling specifications and manuals are found by selecting the products below. Crimp Height Specifications are then contained in the Application Tooling Specification document.*

**Global**

Description	Product #
C-Grid Insertion Tool	<a href="#">0690080140</a>
Extraction Aid	<a href="#">0690080003</a>
Hand Crimp Tool	<a href="#">0638190200</a>
T2 Terminator Die	<a href="#">0638514100</a>
FineAdjust™	<a href="#">0638614100</a>

**Japan**

Description	Product #
-------------	-----------

Applicator for M211A 0571983000  
Bench Press, 22-24  
AWG, for 90119  
Crimp Terminal

This document was generated on 05/28/2010

**PLEASE CHECK [WWW.MOLEX.COM](http://WWW.MOLEX.COM) FOR LATEST PART INFORMATION**

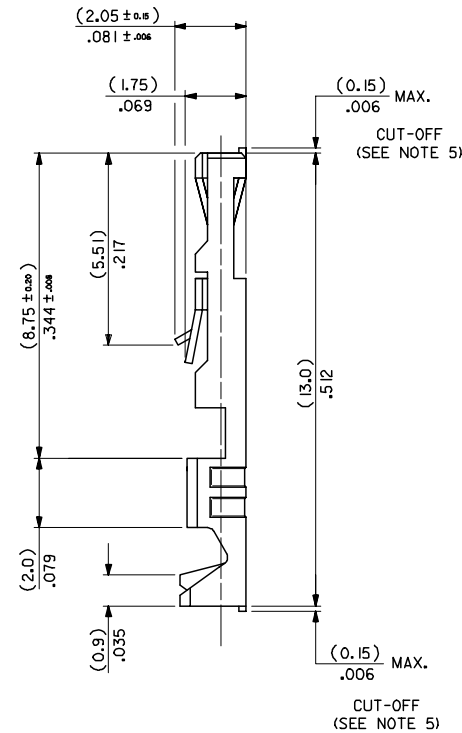
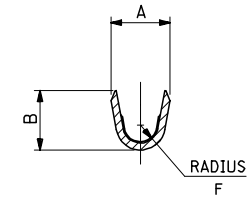
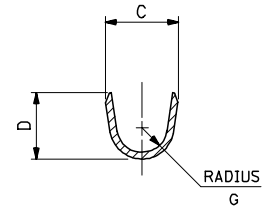
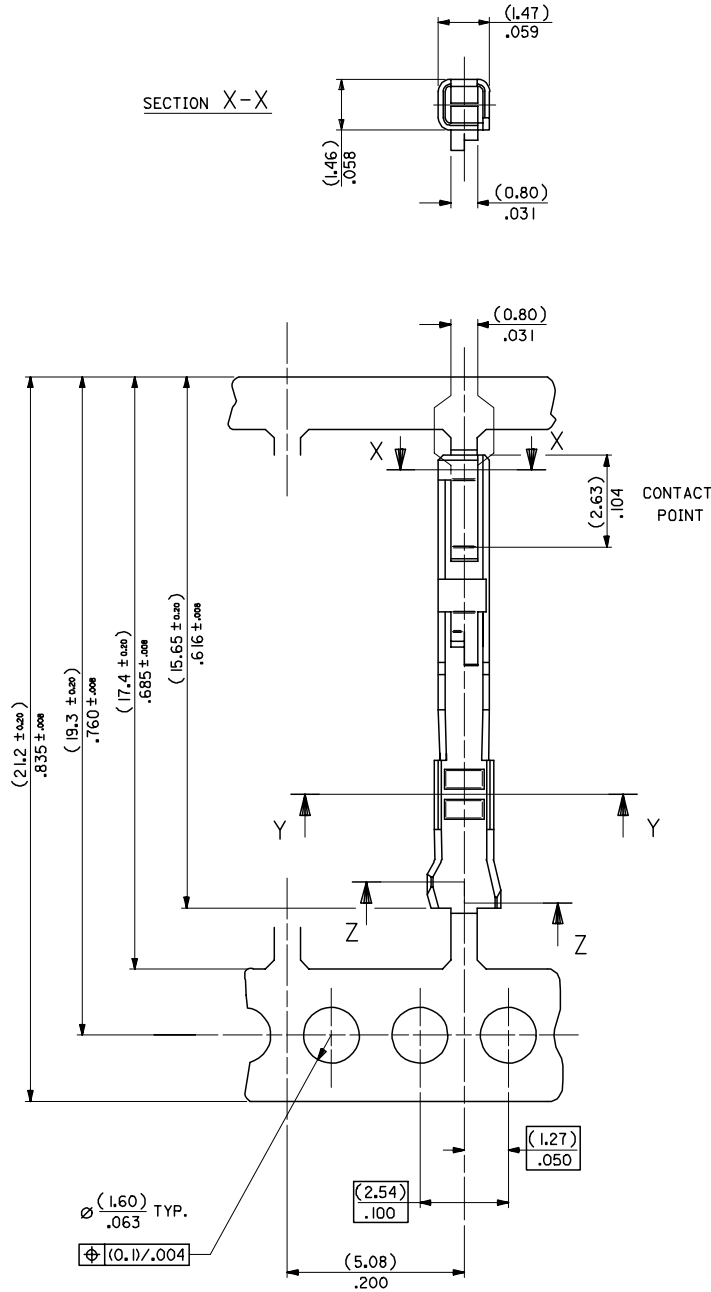

NOTES:

1. MATERIAL -  
PHOSPHOR BRONZE CDA 521  
THICKNESS:  $(0.200)_{-0.008}$   
TENSILE STRENGTH: 655-760 N/mm<sup>2</sup>  
PLATING - SEE SHEET 2
2. FOR DIMENSIONS A, B, C, D, F & G  
SEE SHEET 2
3. FOR WIRE SIZE & INSULATION DIA  
SEE SHEET 2
4. THIS TERMINAL TO MATE WITH  
 $(0.635)_{-0.025}$  SQUARE PIN
5. MAX BURR AFTER CUT-OFF  
 $(0.025)_{-0.001}$

REMOVED LEAD REF. EC NO. E2006-0155 DRAWN: JDENNEHY 2005/08/29 CHKD: DMORIARTY 2005/08/29 APPR: JDENNEHY 2005/09/05	QUALITY SYMBOLS $\nabla=0$ $\nabla=0$	GENERAL TOLERANCES (UNLESS SPECIFIED)		DIMENSION STYLE MM ONLY		SCALE 10:1	DESIGN UNITS METRIC	THIRD ANGLE PROJECTION	
		mm	INCH	DRAWN BY NPC	DATE 1987/08/27	TITLE C-GRID III FEMALE CRIMP TERMINAL			
		4 PLACES ± ---	± ---	CHECKED BY D.MORIARTY	DATE 2005/08/26	MOLEX INCORPORATED			
		3 PLACES ± ---	± .004	APPROVED BY JDENNEHY	DATE 2005/08/26				
		2 PLACES ± 0.1	± .008	MATERIAL NO. SD-90119		DOCUMENT NO. SD-90119		SHEET NO. 1 OF 2	
		1 PLACE ± 0.2	± ---	DRAFT WHERE APPLICABLE MUST REMAIN WITHIN DIMENSIONS					
		ANGULAR ± 5 °		SEE CHART					
		THIS DRAWING CONTAINS INFORMATION THAT IS PROPRIETARY TO MOLEX INCORPORATED AND SHOULD NOT BE USED WITHOUT WRITTEN PERMISSION							

10 9 8 7 6 5 4 3 2 1

PART No	PLATING	REELING	WIRE SIZE (AWG)	INSULATION RANGE	CRIMP DIMENSIONS					
					WIRE BARREL			INSULATION BARREL		
					A $\pm \frac{(0.15)}{.006}$	B $\pm \frac{(0.15)}{.006}$	F $\pm \frac{(0.15)}{.006}$	C $\pm \frac{(0.15)}{.006}$	D $\pm \frac{(0.15)}{.006}$	G $\pm \frac{(0.15)}{.006}$
90119-0109	A	L.H FEED	22,24	(1.02-1.47)	(1.70)	(1.70)	(0.51)	(2.10)	(1.90)	(0.70)
-0110	E			.040-.058	.067	.067	0.20	.083	.075	0.27
-0111	F			26,28	(0.76-1.22)	(1.37)	(1.37)	(0.28)	(2.00)	(1.70)
-0120	A		.030-.048		.054	.054	0.11	.079	.067	0.24
-0121	E		22,24		(1.02-1.47)	(1.70)	(1.70)	(0.51)	(2.10)	(1.90)
-0122	F			.040-.058	.067	.067	0.20	.083	.075	0.27
-2109	A	26,28		(0.76-1.22)	(1.37)	(1.37)	(0.28)	(2.00)	(1.70)	(0.60)
-2110	E		.030-.048	.054	.054	0.11	.079	.067	0.24	
-2111	F		LOOSE PIECE PARTS	(1.02-1.47)	(1.70)	(1.70)	(0.51)	(2.10)	(1.90)	(0.70)
-2120	A	.040-.058		.067	.067	0.20	.083	.075	0.27	
-2121	E	90119-2122		(0.76-1.22)	(1.37)	(1.37)	(0.28)	(2.00)	(1.70)	(0.60)
-2122	F		.030-.048	.054	.054	0.11	.079	.067	0.24	

TYPE	PLATING
A	PRE-PLATED HOT DIP TIN (1.0 to 2.5 um)/.00004 TO .0001
E	(1.27 TO 1.78um)/.00005 TO .00007 NICKEL OVERALL. (0.38 TO 0.64um)/.000015 TO .000025 GOLD ON CONTACT AREA. (3.0 TO 5.0 um)/.00012 TO .0002 TIN ON TERMINATION AREA.
F	(1.27 TO 1.78um)/.00005 TO .00007 NICKEL OVERALL. (0.76 TO 01.0 um)/.00003 TO .00004 GOLD ON CONTACT AREA. (3.0 TO 5.0 um)/.00012 TO .0002 TIN ON TERMINATION AREA.

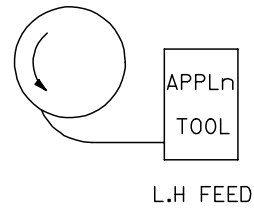

REMOVED LEAD REF. EC NO: E2006-0155 DRWN: DENNEHY 2005/08/29 CHKD:DMORIARTY 2005/08/29 APPR: DENNEHY 2005/09/05	DESCRIPTION REV K	QUALITY SYMBOLS ▽=0 ◻=0	GENERAL TOLERANCES (UNLESS SPECIFIED) <table border="1"> <tr> <td></td> <td>mm</td> <td>INCH</td> </tr> <tr> <td>4 PLACES</td> <td>±---</td> <td>±---</td> </tr> <tr> <td>3 PLACES</td> <td>±---</td> <td>±---</td> </tr> <tr> <td>2 PLACES</td> <td>±---</td> <td>±---</td> </tr> <tr> <td>1 PLACE</td> <td>±---</td> <td>±---</td> </tr> <tr> <td colspan="3">ANGULAR ±---°</td> </tr> </table>		mm	INCH	4 PLACES	±---	±---	3 PLACES	±---	±---	2 PLACES	±---	±---	1 PLACE	±---	±---	ANGULAR ±---°			DIMENSION STYLE MM ONLY	SCALE ---	DESIGN UNITS METRIC	THIRD ANGLE PROJECTION
			mm	INCH																					
		4 PLACES	±---	±---																					
		3 PLACES	±---	±---																					
2 PLACES	±---	±---																							
1 PLACE	±---	±---																							
ANGULAR ±---°																									
DRAWN BY: KS DATE: 1987/09/01 CHECKED BY: DMORIARTY DATE: 2005/08/26 APPROVED BY: JDENNEHY DATE: 2005/08/26			TITLE C-GRID III FEMALE CRIMP TERMINAL																						
DRAFT WHERE APPLICABLE MUST REMAIN WITHIN DIMENSIONS			MATERIAL NO. SEE CHART		DOCUMENT NO. SD-90119		SHEET NO. 2 OF 2																		
THIS DRAWING CONTAINS INFORMATION THAT IS PROPRIETARY TO MOLEX INCORPORATED AND SHOULD NOT BE USED WITHOUT WRITTEN PERMISSION																									

9 8 7 6 5 4 3 2 1