

5 V Stereo DAC with 2 V_{RMS} Ground-centered Output

Features

- ◆ Advanced Multi-bit Delta-Sigma Modulator
- ◆ 101 dB A-wt Dynamic Range
- ◆ -86 dB THD+N
- ◆ Single-ended Ground Centered Analog Architecture
 - No DC-blocking Capacitors Required
 - Integrated Inverting Charge Pump
 - Filtered Line-level Outputs
 - 2 V_{RMS} Full-scale Output
- ◆ Low-latency Digital Filtering
- ◆ Supports Sample Rates up to 192 kHz
- ◆ 24-bit I²S Input
- ◆ +5 V Analog Supply with Integrated Inverting Charge Pump and Regulator for Core Logic, and +1.8 V to +5 V Interface Power Supplies
- ◆ 50 mW Power Consumption
- ◆ 14-pin SOIC, Lead-free Assembly

Description

The CS4354 is a complete stereo digital-to-analog system including digital interpolation, third-order multi-bit delta-sigma digital-to-analog conversion, digital de-emphasis, analog filtering, and on-chip 2 V_{RMS} line-level driver from a 5 V supply.

The advantages of this architecture include ideal differential linearity, no distortion mechanisms due to resistor matching errors, no linearity drift over time and temperature, high tolerance to clock jitter, and a minimal set of external components.

The CS4354 is available in a 14-pin SOIC package in Commercial (-40°C to +85°C) grade. The CDB4354 Customer Demonstration Board is also available for device evaluation and implementation suggestions. Please see “[Ordering Information](#)” on page 23 for complete details.

These features are ideal for cost-sensitive, 2-channel audio systems including video game consoles, Blu-Ray Disc® and DVD players, set-top boxes, digital TVs, and DAB/DMB devices.

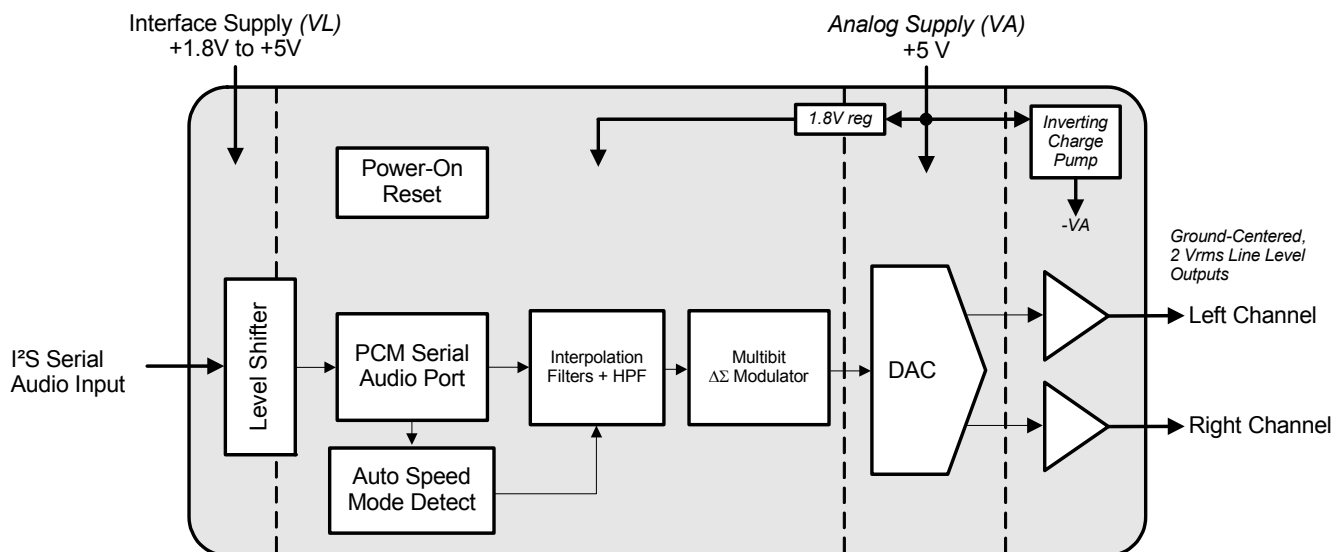

TABLE OF CONTENTS

1. PIN DESCRIPTIONS	4
2. CHARACTERISTICS AND SPECIFICATIONS	5
RECOMMENDED OPERATING CONDITIONS	5
ABSOLUTE MAXIMUM RATINGS	5
DAC ANALOG CHARACTERISTICS	6
COMBINED DIGITAL AND ON-CHIP ANALOG FILTER CHARACTERISTICS	7
SWITCHING SPECIFICATIONS - SERIAL AUDIO INTERFACE	8
DIGITAL INTERFACE CHARACTERISTICS	10
INTERNAL POWER-ON RESET THRESHOLD VOLTAGES	10
DC ELECTRICAL CHARACTERISTICS	11
2.1 Digital I/O Pin Characteristics	11
3. TYPICAL CONNECTION DIAGRAM	12
4. APPLICATIONS	13
4.1 Ground-Centered Line Outputs	13
4.2 Sample Rate Range/Operational Mode Detect	13
4.3 System Clocking	13
4.4 Serial Clock	14
4.4.1 External Serial Clock Mode	14
4.4.2 Internal Serial Clock Mode	14
4.4.2.1 De-Emphasis Control	14
4.5 Internal High-Pass Filter	15
4.6 Digital Interface Format	15
4.7 Internal Power-On Reset	15
4.8 Initialization	16
4.9 Recommended Power-Up and Power-Down Sequences	18
4.9.1 Power-Up Sequence	18
4.9.2 Power-Down Sequence	18
4.10 Grounding and Power Supply Arrangements	18
4.10.1 Capacitor Placement	18
5. COMBINED DIGITAL AND ON-CHIP ANALOG FILTER RESPONSE PLOTS	19
6. PARAMETER DEFINITIONS	21
7. PACKAGE INFORMATION	22
7.1 Dimensions	22
7.2 Thermal Characteristics	22
8. ORDERING INFORMATION	23
9. REVISION HISTORY	24

LIST OF FIGURES

Figure 1. External Serial Clock Mode Input Timing	9
Figure 2. Internal Serial Clock Mode Input Timing	9
Figure 3. Internal Serial Clock Generation	9
Figure 4. Power-On Reset Threshold Sequence	10
Figure 5. Typical Connection Diagram	12
Figure 6. CS4354 Data Format (I ² S)	14
Figure 7. De-Emphasis Curve, F _s = 44.1 kHz	15
Figure 8. Internal Power-On Reset Circuit	15
Figure 9. Initialization and Power-Down Sequence Diagram	17
Figure 10. Single-Speed Stopband Rejection	19
Figure 11. Single-Speed Transition Band	19
Figure 12. Single-Speed Transition Band (detail)	19
Figure 13. Single-Speed Passband Ripple	19
Figure 14. Double-Speed Stopband Rejection	19

Figure 15. Double-Speed Transition Band	19
Figure 16. Double-Speed Transition Band (detail)	20
Figure 17. Double-Speed Passband Ripple	20
Figure 18. Quad-Speed Stopband Rejection	20
Figure 19. Quad-Speed Transition Band	20
Figure 20. Quad-Speed Transition Band (detail)	20
Figure 21. Quad-Speed Passband Ripple	20

LIST OF TABLES

Table 1. Power-On Reset Threshold Voltages	10
Table 2. Digital I/O Pin Characteristics	11
Table 3. CS4354 Operational Mode Auto-Detect	13
Table 4. Common MCLK and LRCK Frequencies	13
Table 5. Internal SCLK Frequencies	14

1. PIN DESCRIPTIONS

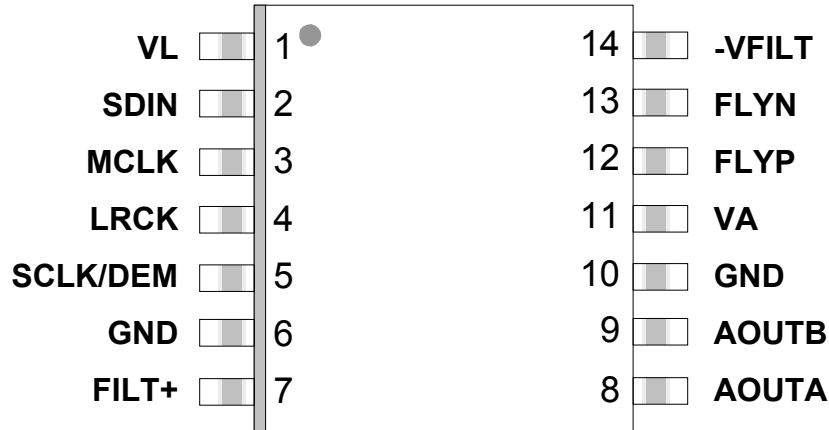

Pin Name	Pin #	Pin Description
VL	1	Serial Audio Interface Power (Input) - Positive power for the serial audio interface.
SDIN	2	Serial Audio Data Input (Input) - Input for two's complement serial audio data.
MCLK	3	Master Clock (Input) - Clock source for the delta-sigma modulator and digital filters.
LRCK	4	Left / Right Clock (Input) - Determines which channel, Left or Right, is currently active on the serial audio data line.
SCLK/DEM	5	Serial Clock (Input) - Serial clock for the serial audio interface.
FILT+	7	Positive Voltage Reference (Output) - Positive reference voltage for the internal sampling circuits.
AOUTA AOUTB	8 9	Analog Outputs (Output) - The full-scale analog line output level is specified in the Analog Characteristics table.
GND	6, 10	Ground (Input) - Ground reference. See Section 4.10 on page 18 for layout considerations.
VA	11	Analog, Charge Pump, and Regulator Power (Input) - Positive power supply for the analog, inverting charge pump, and regulator for the digital core logic sections.
FLYP FLYN	12 13	Inverting Charge Pump Cap Positive/Negative Nodes (Output) - Positive and Negative nodes for the inverting charge pump's flying capacitor.
-VFILT	14	Inverting Charge Pump Filter Connection (Output) - Power supply from the inverting charge pump that provides the negative rail for the output amplifiers.

2. CHARACTERISTICS AND SPECIFICATIONS

RECOMMENDED OPERATING CONDITIONS

GND = 0 V; all voltages with respect to ground. (Note 1)

Parameters		Symbol	Min	Typ	Max	Units
DC Power Supply	Analog power	VA	4.75	5.0	5.25	V
	Interface power	VL	1.4	1.8, 3.3, 5.0	5.25	V
Ambient Operating Temperature (Power Applied)		-CSZ T _A	-40	-	+85	°C

Notes: 1. Device functional operation is guaranteed within these limits. Functionality is not guaranteed or implied outside of these limits. Operation outside of these limits may adversely affect device reliability.

ABSOLUTE MAXIMUM RATINGS

GND = 0 V; all voltages with respect to ground.

Parameters		Symbol	Min	Max	Units
DC Power Supply	Low Voltage Analog Power	VA	-0.3	6.0	V
	Interface Power	VL	-0.3	6.0	V
Input Current, Any Pin Except Supplies		I _{in}	-	±10	mA
Digital Input Voltage (Note 2)	Digital Interface	V _{IN-L}	-0.3	VL+ 0.4	V
Ambient Operating Temperature (Power Applied)		T _A	-55	+125	°C
Storage Temperature		T _{stg}	-65	+150	°C

WARNING: Operation at or beyond these limits may result in permanent damage to the device. Normal operation is not guaranteed at these extremes.

Notes: 2. The maximum over/under voltage is limited by the input current except on the power supply pin.

DAC ANALOG CHARACTERISTICS

Test conditions (unless otherwise specified): $T_A = 25\text{ }^\circ\text{C}$; $V_A = 5\text{ V}$, $V_L = 3.3\text{ V}$; $\text{GND} = 0\text{ V}$; $\text{FILT}+$, $-\text{VFILT}$, and FLYP/N capacitors as shown in [Figure 5 on page 12](#); input test signal is a 997 Hz sine wave at 0 dBFS; measurement bandwidth 20 Hz to 20 kHz.

Parameter	Symbol	Min	Typ	Max	Unit	
Dynamic Performance, $F_s = 48, 96, \text{ and } 192\text{ kHz}$ (Notes 3, 5)						
Dynamic Range	24-bit A-Weighted		95	101	-	dB
		unweighted	92	98	-	dB
	16-bit A-Weighted		-	96	-	dB
		unweighted		-	93	-
Total Harmonic Distortion + Noise	24-bit	0 dB	-	-86	-80	dB
		-20 dB	-	-78	-72	dB
		-60 dB	-	-38	-32	dB
	16-bit	0 dB	-	-86	-	dB
		-20 dB	-	-73	-	dB
		-60 dB	-	-33	-	dB
THD+N						
Idle Channel Noise / Signal-to-Noise Ratio	(A-wt)	-	101	-	dB	
Interchannel Isolation	(1 kHz)	-	100	-	dB	
Analog Output (Note 4)						
Full Scale AOUTx Output Voltage	(Notes 6, 7)		$0.38 \cdot V_A$	$0.40 \cdot V_A$	$0.42 \cdot V_A$	V_{RMS}
			$1.07 \cdot V_A$	$1.13 \cdot V_A$	$1.19 \cdot V_A$	V_{pp}
Interchannel Gain Mismatch		-	0.1	-	dB	
Output Offset		-	± 1	± 8	mV	
Gain Drift		-	100	-	ppm/ $^\circ\text{C}$	
Output Impedance	Z_{OUT}	-	100	-	Ω	
Load Resistance	R_L	3	-	-	k Ω	
Load Capacitance	C_L	-	-	100	pF	

- Notes:**
3. Measured at the output of the external low-pass filter on AOUTx as shown in [Figure 5 on page 12](#).
 4. Measured between the AOUTx and GND pins.
 5. One LSB of triangular PDF dither is added to data.
 6. Does not include attenuation due to Z_{OUT} . Additional impedance between the AOUTx pin and the load will lower the voltage delivered to the load.
 7. V_{PP} is the controlling specification. V_{RMS} specification valid for sine wave signals only.

Note that for sine wave signals: $V_{\text{RMS}} = \frac{V_{\text{PP}}}{2\sqrt{2}}$

COMBINED DIGITAL AND ON-CHIP ANALOG FILTER CHARACTERISTICS

The filter characteristics have been normalized to the sample rate (Fs) and can be referenced to the desired sample rate by multiplying the given characteristic by Fs. Reference level (0 dB) is set at 997 Hz. (Note 11)

Parameter	Min	Typ	Max	Unit	
Single-Speed Mode - 48 kHz					
Passband (Note 8)	to -0.05 dB corner	1.796•10 ⁻⁴	-	0.470	Fs
	to -3 dB corner	1.947•10 ⁻⁵	-	0.500	Fs
Frequency Response 20 Hz to 20 kHz	-0.05	-	+0.05		dB
StopBand	0.550	-	-		Fs
StopBand Attenuation (Note 9)	80 dB	-	-		dB
High Pass Filter Settling Time (input signal goes to 95% of its final value)	-	2.452•10 ⁴ /Fs	-		s
Total Group Delay	-	9.4/Fs	-		s
De-emphasis Error (Note 10)(Relative to 1 kHz)	Fs = 44.1 kHz	-	-	±0.14	dB
Double-Speed Mode - 96 kHz					
Passband (Note 8)	to -0.05 dB corner	8.980•10 ⁻⁵	-	0.290	Fs
	to -3 dB corner	9.736•10 ⁻⁶	-	0.500	Fs
Frequency Response 20 Hz to 20 kHz	-0.05	-	+0.05		dB
StopBand	0.583	-	-		Fs
StopBand Attenuation (Note 9)	82 dB	-	-		dB
High Pass Filter Settling Time (input signal goes to 95% of its final value)	-	4.903•10 ⁴ /Fs	-		s
Total Group Delay	-	7.0/Fs	-		s
Quad-Speed Mode - 192 kHz					
Passband (Note 8)	to -0.05 dB corner	4.490•10 ⁻⁵	-	0.253	Fs
	to -3 dB corner	4.868•10 ⁻⁶	-	0.486	Fs
Frequency Response 20 Hz to 20 kHz	-0.05	-	+0.05		dB
StopBand	0.630	-	-		Fs
StopBand Attenuation (Note 9)	85 dB	-	-		dB
High Pass Filter Settling Time (input signal goes to 95% of its final value)	-	9.807•10 ⁴ /Fs	-		s
Total Group Delay	-	4.9/Fs	-		s

Notes: 8. Response is clock-dependent and will scale with Fs.

9. For Single- and Double-Speed Mode, the Measurement Bandwidth is from stopband to 3 Fs.
For Quad-Speed Mode, the Measurement Bandwidth is from stopband to 1.34 Fs.

10. De-emphasis is available only in Single-Speed Mode.

11. Amplitude vs. frequency plots of this data are available in [“Combined Digital and On-chip Analog Filter Response Plots”](#) on page 19.

SWITCHING SPECIFICATIONS - SERIAL AUDIO INTERFACE

Parameters	Symbol	Min	Typ	Max	Units
MCLK Frequency		7.6	-	55.3	MHz
MCLK Duty Cycle		45	-	55	%
Input Sample Rate (Note 12) All MCLK/LRCK ratios combined (SSM) 256x, 384x, 512x, 768x, 1024x (DSM) 128x, 192x, 256x, 384x, 512x (QSM) 128x, 192x, 256x	Fs	30	-	216	kHz
		30	-	54	kHz
		84	-	108	kHz
		170	-	216	kHz
External SCLK Mode					
LRCK Duty Cycle		45	-	55	%
SCLK Pulse Width Low	t_{sckl}	20	-	-	ns
SCLK Pulse Width High	t_{sckh}	20	-	-	ns
SCLK Duty Cycle		45	-	55	%
SCLK rising to LRCK edge delay	t_{slrd}	20	-	-	ns
LRCK edge to SCLK rising delay	t_{slrs}	20	-	-	ns
SDIN valid to SCLK rising setup time	t_{sdls}	20	-	-	ns
SCLK rising to SDIN hold time	t_{sdh}	20	-	-	ns
Internal SCLK Mode					
LRCK Duty Cycle		$50\% - \frac{1}{2 \times MCLK}$	-	$50\% + \frac{1}{2 \times MCLK}$	-
SCLK Period (Note 13)	t_{sckw}	$\frac{10^9}{SCLK}$	-	-	ns
MCLK falling to LRCK edge	t_{mckf}	$\frac{-10^9}{4 \times MCLK}$	-	$\frac{10^9}{4 \times MCLK}$	ns
LRCK edge to SCLK rising	t_{sckr}	-	(Note 14)	-	ns
SDIN valid to SCLK rising setup time	t_{sdls}	$\frac{10^9}{512 \times Fs} + 10$	-	-	ns
SCLK rising to SDIN hold time MCLK / LRCK = 1024, 512, 256, 128 MCLK / LRCK = 768, 384, 192	t_{sdh}	$\frac{10^9}{512 \times Fs} + 15$	-	-	ns
		$\frac{10^9}{384 \times Fs} + 15$	-	-	

12. Not all sample rates are supported for all clock ratios. See [Section 4.2 “Sample Rate Range/Operational Mode Detect” on page 13](#) for supported ratios and frequencies. SSM = Single-Speed Mode, DSM = Double-Speed Mode, QSM = Quad-Speed Mode.

13. SCLK period is defined by the SCLK / LRCK ratio. The SCLK / LRCK ratio may be either 32, 48, or 64. See [Table 5 on page 14](#).

$$14. t_{sckr} = \frac{t_{sckw}}{2} + \frac{10^9}{2 \times MCLK} + t_{mckf}$$

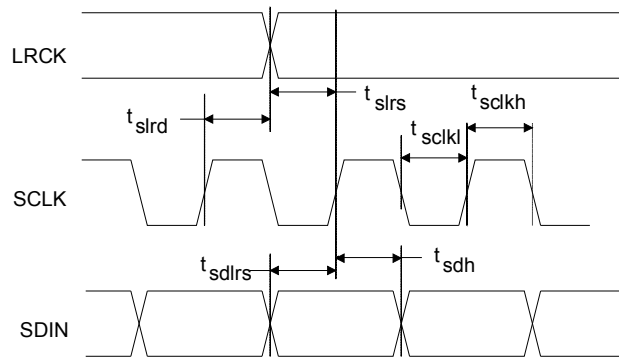
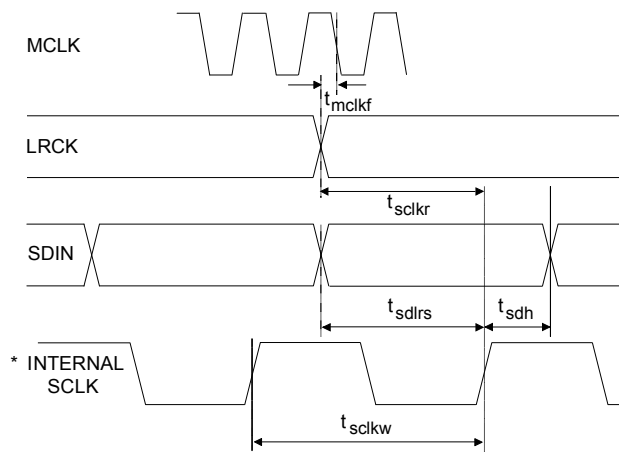
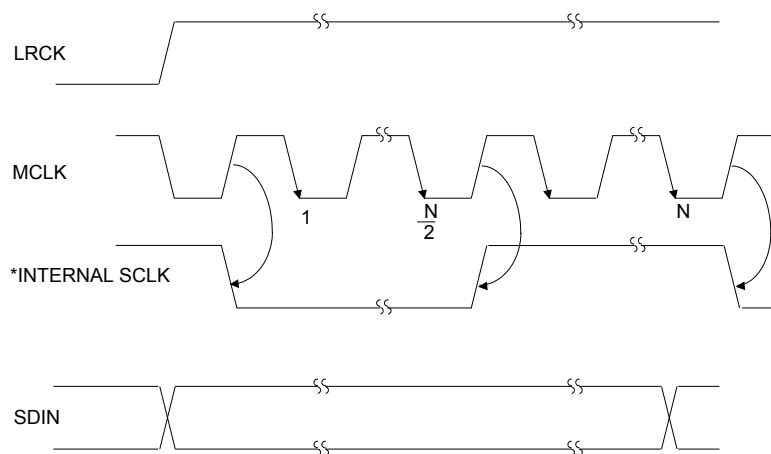

Figure 1. External Serial Clock Mode Input Timing



The SCLK pulses shown are internal to the CS4354.

Figure 2. Internal Serial Clock Mode Input Timing



* The SCLK pulses shown are internal to the CS4354.
N equals MCLK divided by SCLK

Figure 3. Internal Serial Clock Generation

DIGITAL INTERFACE CHARACTERISTICS

Test conditions (unless otherwise specified): GND = 0 V; all voltages with respect to ground.

Parameters	Symbol	Min	Typ	Max	Units
High-Level Input Voltage	V_{IH}	$0.7 \times V_L$	-	-	V
Low-Level Input Voltage	V_{IL}	-	-	$0.3 \times V_L$	V
Input Leakage Current	I_{in}	-	-	± 10	μA
Input Capacitance		-	8	-	pF

INTERNAL POWER-ON RESET THRESHOLD VOLTAGES

Test conditions (unless otherwise specified): GND = 0 V; all voltages with respect to ground.

Parameters	Symbol	Min	Typ	Max	Units
Internal Reset Asserted at Power-On	V_{on1}	-	0.2	-	V
Internal Reset Released at Power-On	V_{on2}	-	3.6	-	V
Internal Reset Asserted at Power-Off	V_{off}	-	3.1	-	V

Table 1. Power-On Reset Threshold Voltages

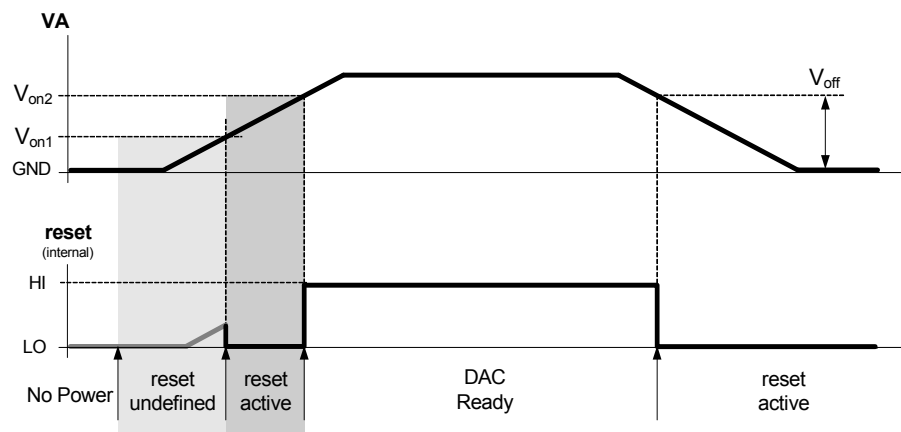

Figure 4. Power-On Reset Threshold Sequence

DC ELECTRICAL CHARACTERISTICS

Test conditions (unless otherwise specified): $V_A = 5\text{ V}$, $V_L = 3.3\text{ V}$; $GND = 0\text{ V}$; $SDIN = 0$; all voltages with respect to ground.

Parameters		Symbol	Min	Typ	Max	Units
Power Supplies						
Power Supply Current (Note 15)	Normal Operation (Note 16)	I_{VA}	-	10	13	mA
		I_{VL}	-	0.1	0.2	mA
	Power-Down (Note 17)	I_{VA}	-	0.5	-	mA
		I_{VL}	-	1	-	μA
Power Dissipation (All Supplies) (Note 15)	Normal Operation (Note 16)		-	50	65	mW
	Power-Down (Note 17)		-	2.5	-	mW
Power Supply Rejection Ratio (Note 18)	(1 kHz) (60 Hz)	PSRR	-	60	-	dB
			-	60	-	dB
DC Output Voltages						
Pin Voltage	FILT+ to GND		-	3.5	-	V
	FLYP to FLYN		-	4.9	-	V
	GND to -VFILT		-	4.7	-	V

Notes: 15. Power supply current increases with increasing sample rate and increasing MCLK frequency. Typical values are based on $F_s = 48\text{ kHz}$ and $MCLK = 12.288\text{ MHz}$. Maximum values are based on highest sample rate and highest MCLK frequency; see [Switching Specifications - Serial Audio Interface](#). Variance between speed modes is small.

16. During normal operation, $SDIN = 997\text{ Hz}$ sine wave at 0 dBFS with load resistance $R_L = 3\text{ k}\Omega$.

17. Power-down is defined as all clock and data lines held static low. All digital inputs have a weak pull-down (approximately $50\text{ k}\Omega$) which is only present during power on reset. Opposing this pull-down will increase the power-down current.

18. Valid with the recommended capacitor values as shown in the typical connection diagram in [Section 5](#).

2.1 Digital I/O Pin Characteristics

Input and output levels and associated power supply voltage are shown in [Table 2](#). Logic levels should not exceed the corresponding power supply voltage.

Pin Name	Power Supply	I/O	Driver	Receiver
MCLK	V_L	Input	-	1.8 V - 5 V
LRCK	V_L	Input	-	1.8 V - 5 V
SCLK	V_L	Input	-	1.8 V - 5 V
SDIN	V_L	Input	-	1.8 V - 5 V

Table 2. Digital I/O Pin Characteristics

3. TYPICAL CONNECTION DIAGRAM

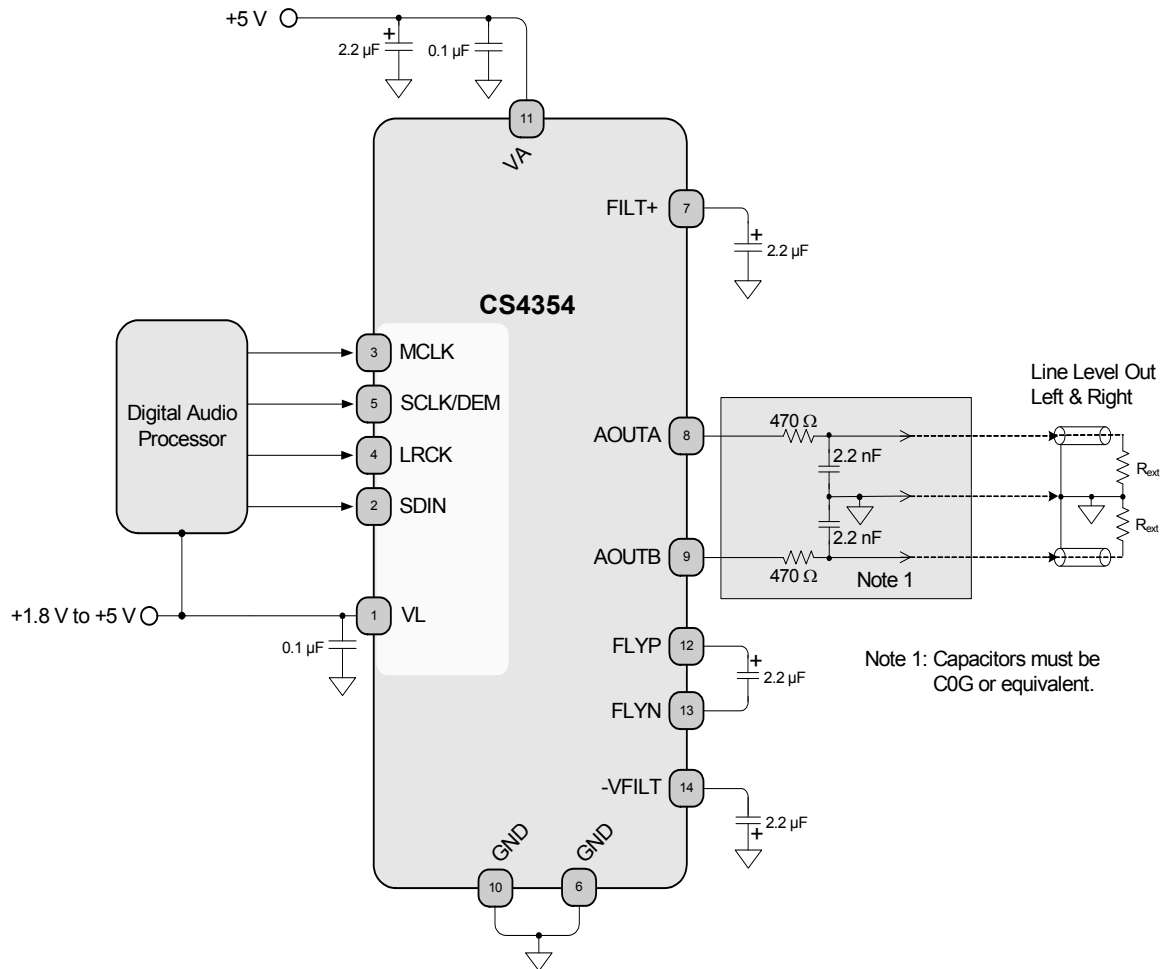

Figure 5. Typical Connection Diagram

4. APPLICATIONS

4.1 Ground-Centered Line Outputs

An on-chip charge pump creates a negative supply which allows the full-scale output swing to be centered around ground. This eliminates the need for large DC-blocking capacitors which create audible pops at power-on and provides improved low frequency response. See the [DAC Analog Characteristics](#) table for the complete specifications of the full-scale output voltage. It should be noted that external output impedance between the AOUTx pin and the load will lower the voltage delivered to the load.

4.2 Sample Rate Range/Operational Mode Detect

The CS4354 operates in one of three operational modes. The device will auto-detect the correct mode when the input sample rate (Fs), defined by the LRCK frequency, falls within one of the ranges illustrated in [Table 3](#). Sample rates outside the specified range for each mode are not supported. In addition to a valid LRCK frequency, a valid serial clock (SCLK) and master clock (MCLK) must also be applied to the device for speed mode auto-detection; see [Figure 9](#).

Input Sample Rate (Fs)	Mode
30 kHz - 54 kHz	Single-Speed Mode
84 kHz - 108 kHz	Double-Speed Mode
170 kHz - 216 kHz	Quad-Speed Mode

Table 3. CS4354 Operational Mode Auto-Detect

4.3 System Clocking

The device requires external generation of the master (MCLK), left/right (LRCK) and serial (SCLK) clocks. The left/right clock, defined also as the input sample rate (Fs), must be synchronously derived from the MCLK signal according to specified ratios. The specified ratios of MCLK to LRCK, along with several standard audio sample rates and the required MCLK frequency, are illustrated in [Table 4 on page 13](#).

Refer to [Section 4.6](#) for the required SCLK timing associated with the selected Digital Interface Format and to [“Switching Specifications - Serial Audio Interface” on page 8](#) for the maximum allowed clock frequencies.

LRCK (kHz)	MCLK (MHz)						
	128x	192x	256x	384x	512x	768x	1024x
32	-	-	8.1920	12.2880	16.3840	24.5760	32.7680
44.1	-	-	11.2896	16.9344	22.5792	33.8688	45.1580
48	-	-	12.2880	18.4320	24.5760	36.8640	49.1520
88.2	11.2896	16.9344	22.5792	33.8688	45.1584	-	-
96	12.2880	18.4320	24.5760	36.8640	49.1520	-	-
176.4	22.5792	33.8688	45.1584	-	-	-	-
192	24.5760	36.8640	49.1520	-	-	-	-
Mode	QSM			DSM		SSM	

Table 4. Common MCLK and LRCK Frequencies

4.4 Serial Clock

The serial clock controls the shifting of data into the input data buffers. The CS4354 supports both external and internal serial clock generation modes. Refer to [Figure 6](#) for a diagram of the I²S data format.

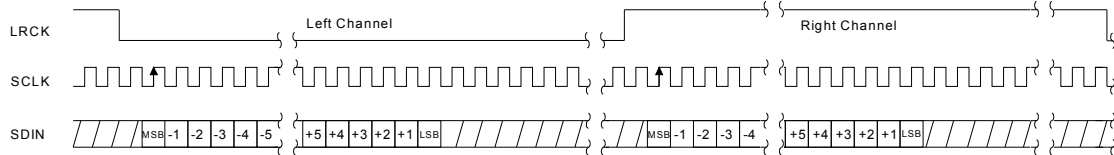

Figure 6. CS4354 Data Format (I²S)

In order to support selectable de-emphasis without a dedicated pin, pin 5 (SCLK/DEM) functions both as a serial clock input and a de-emphasis select. In typical applications where de-emphasis is not required, the SCLK/DEM pin is the input for an external serial clock - this is known as the External Serial Clock Mode. To enable de-emphasis selection, the Internal Serial Clock Mode has to be used. Sections [4.4.1](#) and [4.4.2](#) describe this feature in detail.

4.4.1 External Serial Clock Mode

The CS4354 will enter the External Serial Clock Mode when 16 low to high transitions are detected on the DEM/SCLK pin during any phase of the LRCK period. When this mode is enabled, the Internal Serial Clock Mode and de-emphasis filter are disabled (see [Figure 9](#) for flow diagram).

In the External Serial Clock Mode, the CS4354 will support I²S data up to 24-bit, with data valid on the rising edge of SCLK.

4.4.2 Internal Serial Clock Mode

The CS4354 will switch to Internal Serial Clock Mode if no low to high transitions are detected on the DEM/SCLK pin for 2 consecutive frames of LRCK (see [Figure 9](#) for flow diagram). In the Internal Serial Clock Mode, the serial clock is internally derived and synchronous with MCLK and LRCK. The SCLK/LRCK frequency ratio is either 32, 48, or 64 depending on the speed mode and MCLK frequency. Operation in this mode is identical to operation with an external serial clock synchronized with LRCK. This mode allows access to the digital de-emphasis function. Refer to [Table 5](#) for details (all frequencies listed as multiples of LRCK frequency).

Speed Mode	MCLK =	128x	192x	256x	384x	512x	768x	1024x
SSM		-	-	64x	48x	64x	64x	64x
DSM		-	48x	-	-	-	-	-
QSM		-	32x	32x	-	-	-	-

Table 5. Internal SCLK Frequencies

4.4.2.1 De-Emphasis Control

The device includes on-chip digital de-emphasis. [Figure 7](#) shows the de-emphasis curve for F_s equal to 44.1 kHz. The frequency response of the de-emphasis curve scales with changes in the sample rate, F_s . The de-emphasis error will increase for sample rates other than 44.1 kHz.

When the SCLK/DEM pin is connected to VL (internal SCLK mode), the 44.1 kHz de-emphasis filter is activated. When the SCLK/DEM pin is connected to GND, the de-emphasis filter is disabled. For more information see “[Internal Serial Clock Mode](#)” on page 14.

De-emphasis selection is disabled in the external SCLK mode.

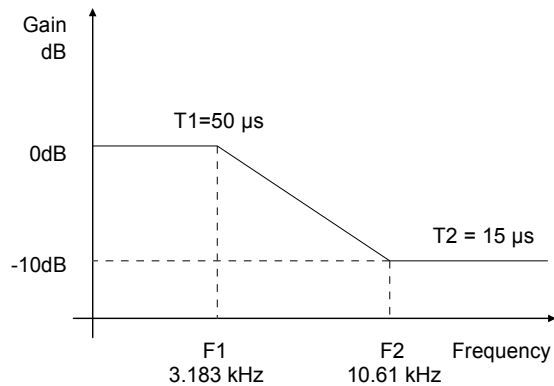

Figure 7. De-Emphasis Curve, $F_s = 44.1$ kHz

Note: De-emphasis is only available in Single-Speed Mode.

4.5 Internal High-Pass Filter

The CS4354 includes an internal digital high-pass filter. This filter prevents a constant digital offset from creating a DC voltage on the analog output pins. The filter's corner frequency is well below the audio band; see "Switching Specifications - Serial Audio Interface" on page 8 for filter specifications.

4.6 Digital Interface Format

The device accepts audio samples in the industry standard I²S format only.

For an illustration of the required relationship between the LRCK, SCLK and SDIN, see Figure 6 on page 14. SDIN is valid on the rising edge of SCLK. For more information about serial audio formats, refer to Cirrus Logic Application Note AN282: *The 2-Channel Serial Audio Interface: A Tutorial*, available at <http://www.cirrus.com>.

4.7 Internal Power-On Reset

The CS4354 features an internal power-on reset (POR) circuit. This circuit monitors the VA supply and automatically asserts or releases an internal reset of the DAC's digital circuitry when the supply reaches defined thresholds (see "Internal Power-On Reset Threshold Voltages" on page 10). No external clocks are required for the POR circuit to function.

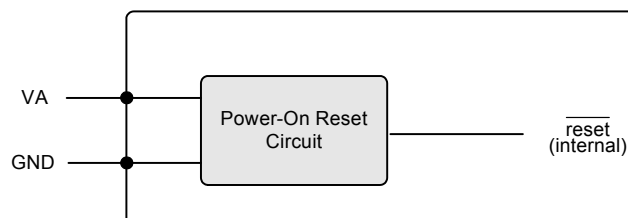

Figure 8. Internal Power-On Reset Circuit

When power is first applied, the POR circuit monitors the VA supply voltage to determine when it reaches a defined threshold, V_{on1} . At this time, the POR circuit asserts the internal reset low, resetting all of the

digital circuitry. Once the VA supply reaches the secondary threshold, V_{on2} , the POR circuit releases the internal reset.

When power is removed and the VA voltage reaches a defined threshold, V_{off} , the POR circuit asserts the internal reset low, resetting all of the digital circuitry.

Note: For correct operation of the internal POR circuit, the voltage on VL must rise before or simultaneously with VA.

4.8 Initialization

When power is first applied, the DAC enters a reset (low power) state at the beginning of the initialization sequence. In this state, the AOUTx pins are weakly pulled to ground and FILT+ is connected to GND.

The device will remain in the reset state until V_{ON2} is reached. Once V_{ON2} is reached, the internal digital circuitry is reset and the DAC enters a power-down state until MCLK is applied.

Once MCLK is valid, the device enters an initialization state in which the charge pump powers up and charges the capacitors for the negative voltage supply.

Once LRCK is valid, the number of MCLK cycles is counted relative to the LRCK period to determine the MCLK/LRCK frequency ratio. Next, the device enters the power-up state in which the interpolation filters and delta-sigma modulators are turned on, the internal voltage reference, FILT+, powers up to normal operation, the analog output pull-down resistors are removed, and power is applied to the output amplifiers.

If a valid SCLK is applied, the device will clock in data according to the applied SCLK. If no SCLK is present, the device will clock in data using the derived internal SCLK (see [Figure 3 on page 9](#)) and will apply the de-emphasis filter according to [Section 4.4.2.1 on page 14](#).

After this power-up state sequence is complete, normal operation begins and analog output is generated.

If valid MCLK, LRCK, and SCLK are applied to the DAC before V_{ON2} is reached, the total time from V_{ON2} to the analog audio output from AOUTx is less than 50 ms.

See [Figure 9](#) for a diagram of the device's states and transition conditions.

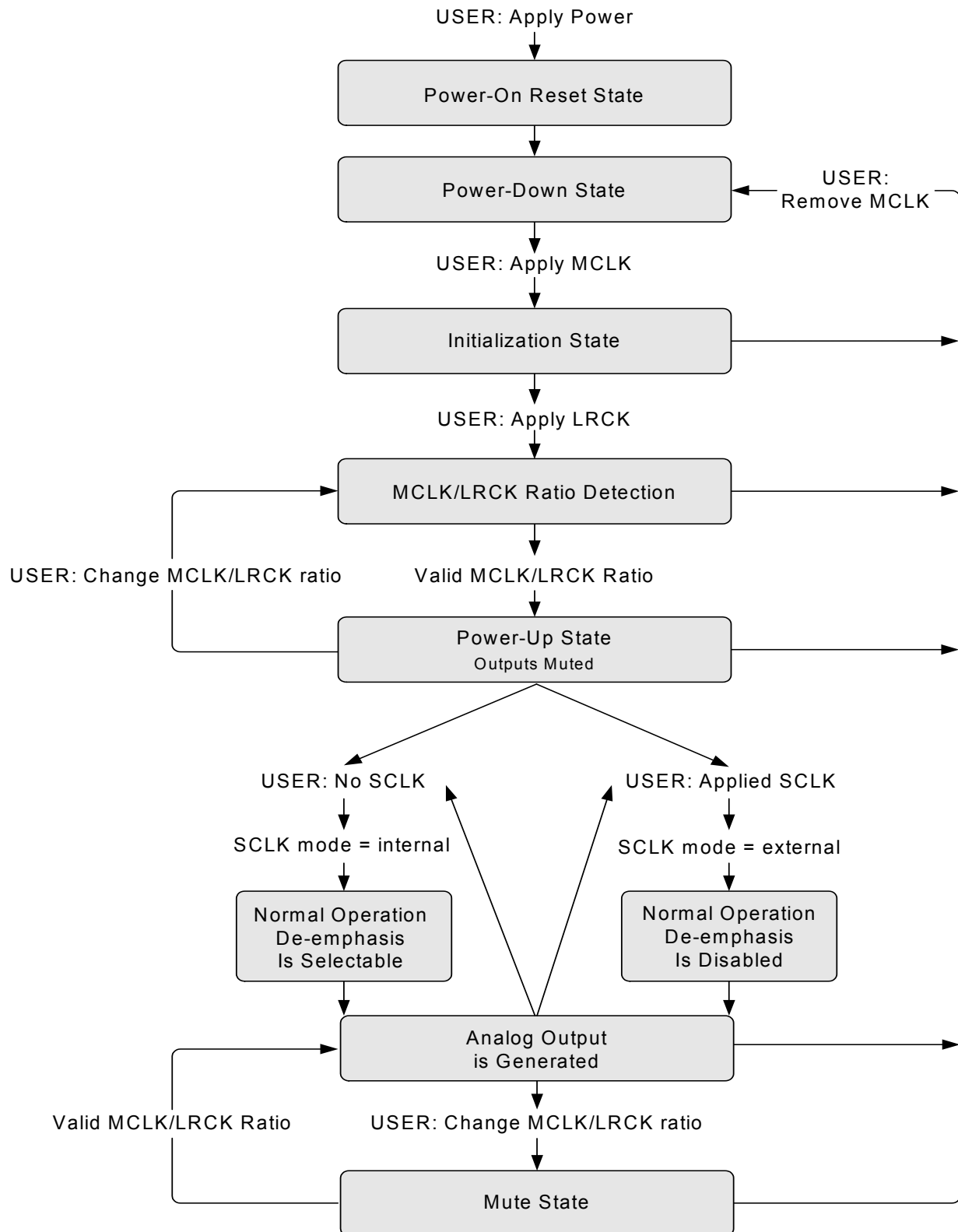

Figure 9. Initialization and Power-Down Sequence Diagram

4.9 Recommended Power-Up and Power-Down Sequences

4.9.1 Power-Up Sequence

Follow the power-up sequence below:

1. Apply power.
2. After the power supplies are stable, provide the correct MCLK, LRCK, and SCLK (only in External Serial Clock Mode) signals to progress from the 'Power-Down State' in the power-up sequence seen in [Figure 9](#). Please refer to [Section 4.4 on page 14](#) for common clock frequencies in the External Serial Clock Mode, and supported modes in the Internal Serial Clock Mode. The sequence will complete and audio will be output from the AOUTx pins within 50 ms after valid clocks are applied.

4.9.2 Power-Down Sequence

Follow the power-down sequence below:

1. For minimal pops, set the input digital data (SDIN) to zero for at least 8192 consecutive samples.
2. Remove the MCLK signal without applying any glitched pulses to the MCLK pin.
3. Remove the power supply voltages.

Note: A glitched pulse is any pulse that is shorter than the period defined by the minimum/maximum MCLK signal duty cycle specification and the nominal frequency of the input MCLK signal. A transient may occur on the analog outputs if the MCLK signal duty cycle specification is violated when the MCLK signal is removed during normal operation; see ["Switching Specifications - Serial Audio Interface" on page 8](#).

4.10 Grounding and Power Supply Arrangements

As with any high-resolution converter, the CS4354 requires careful attention to power supply and grounding arrangements if its potential performance is to be realized. The ["Typical Connection Diagram" on page 12](#) shows the recommended power arrangements with VA and VL connected to clean supplies. It is strongly recommended that a single ground plane be used with the GND pins connected to the common plane; this is important because both pin 6 and pin 10 provide analog ground reference to the CS4354. Should it be necessary to split the ground planes, the CS4354 should be placed entirely in the analog plane. In this configuration, it is critical that the digital and analog ground planes be tied together with a low-impedance connection, ideally a strip of copper on the printed circuit board, at a single point near the CS4354.

All signals, especially clocks, should be kept away from the FILT+ pin in order to avoid unwanted coupling into the DAC.

4.10.1 Capacitor Placement

Decoupling capacitors should be placed as close to the device as possible, with the low-value ceramic capacitor being the closest. To further minimize impedance, these capacitors should be located on the same PCB layer as the device. See [DC Electrical Characteristics](#) for the voltage present across pin pairs. This is useful for choosing appropriate capacitor voltage ratings and orientation if electrolytic capacitors are used.

The CDB4354 evaluation board demonstrates the optimum layout and power supply arrangements.

5. COMBINED DIGITAL AND ON-CHIP ANALOG FILTER RESPONSE PLOTS

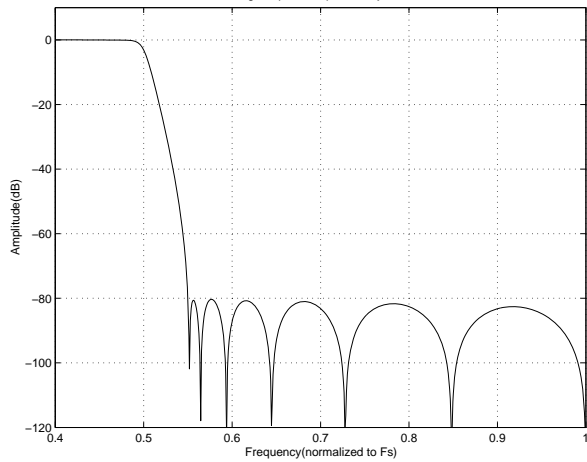

Figure 10. Single-Speed Stopband Rejection

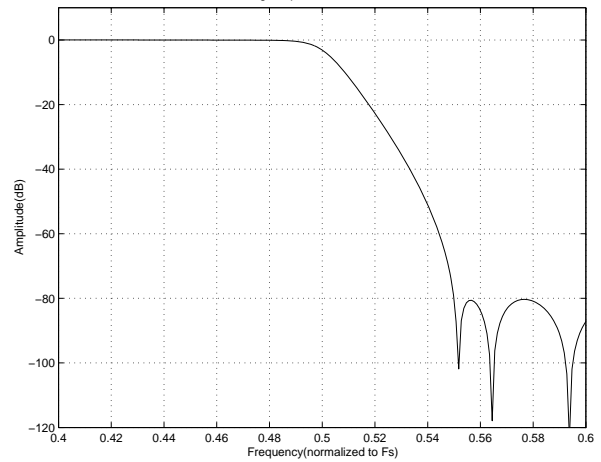

Figure 11. Single-Speed Transition Band

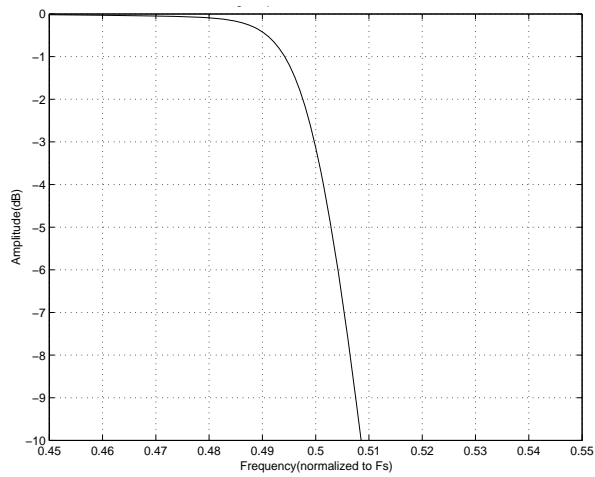

Figure 12. Single-Speed Transition Band (detail)

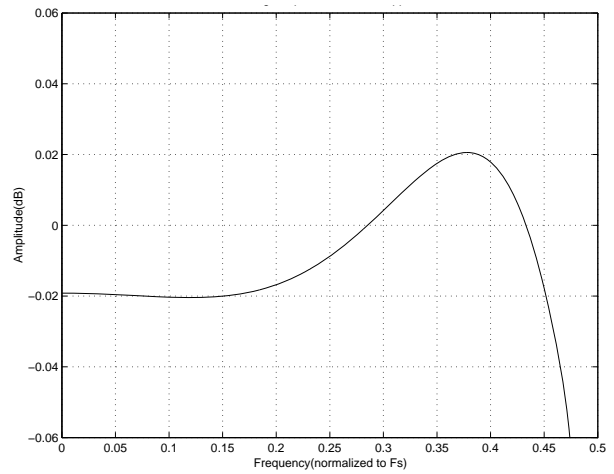

Figure 13. Single-Speed Passband Ripple

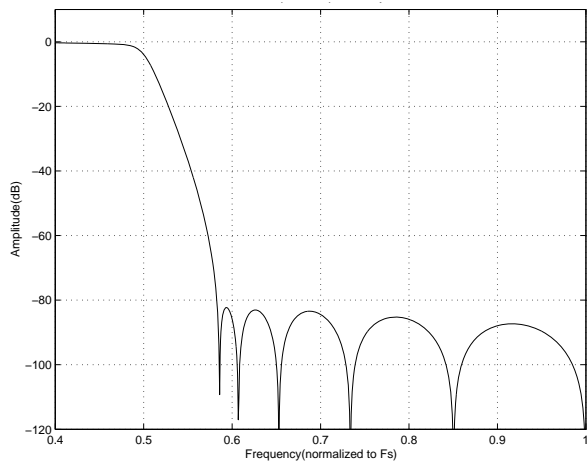

Figure 14. Double-Speed Stopband Rejection

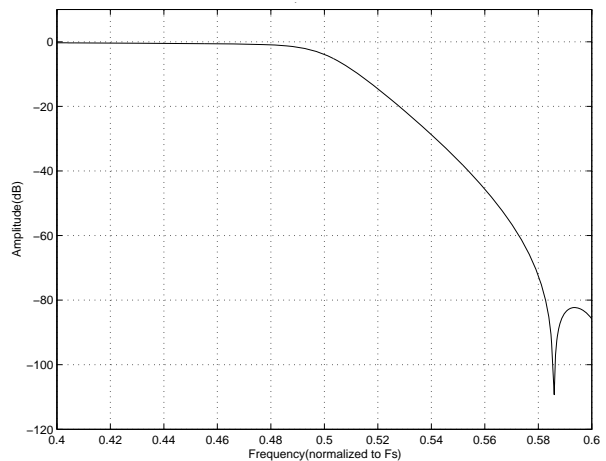
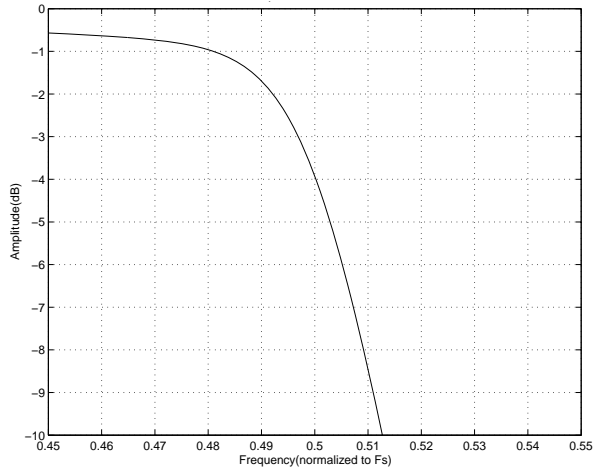
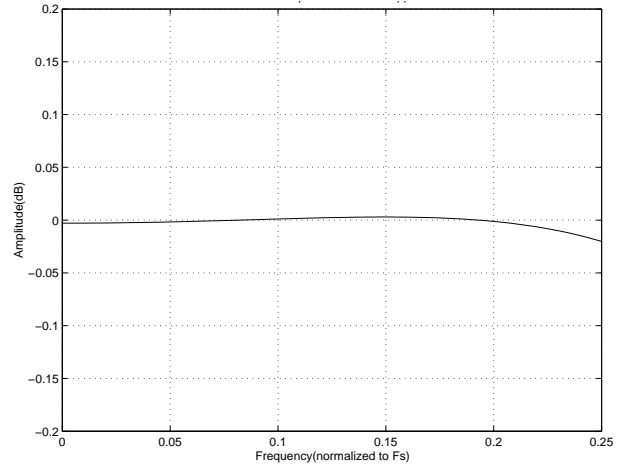
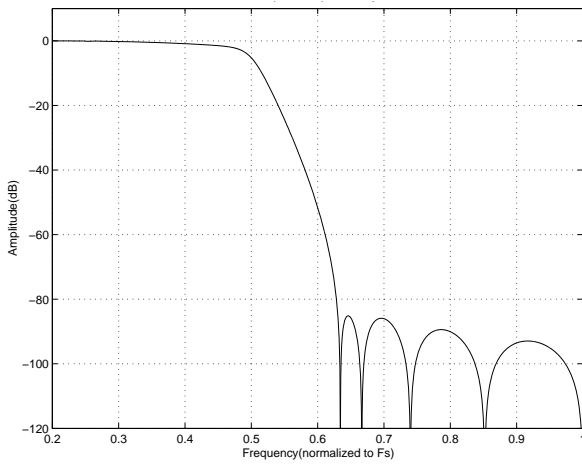
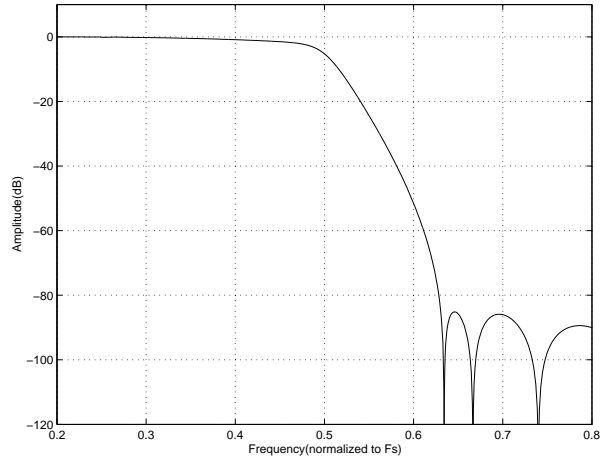
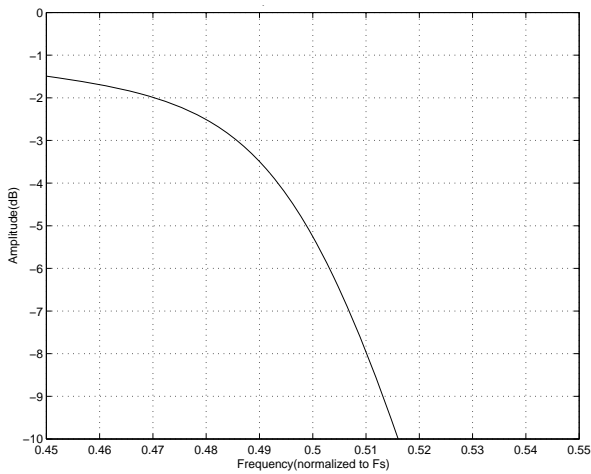
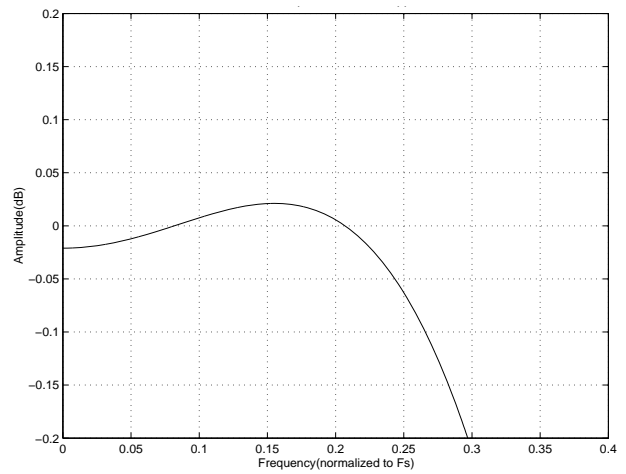

Figure 15. Double-Speed Transition Band

Figure 16. Double-Speed Transition Band (detail)

Figure 17. Double-Speed Passband Ripple

Figure 18. Quad-Speed Stopband Rejection

Figure 19. Quad-Speed Transition Band

Figure 20. Quad-Speed Transition Band (detail)

Figure 21. Quad-Speed Passband Ripple

6. PARAMETER DEFINITIONS

Total Harmonic Distortion + Noise (THD+N)

The ratio of the RMS value of the signal to the RMS sum of all other spectral components over the specified bandwidth (typically 10 Hz to 20 kHz), including distortion components. Expressed in decibels.

Dynamic Range

The ratio of the full-scale RMS value of the signal to the RMS sum of all other spectral components over the specified bandwidth. Dynamic range is a signal-to-noise measurement over the specified bandwidth made with a -60 dBFS signal. 60 dB is then added to the resulting measurement to refer the measurement to full scale. This technique ensures that the distortion components are below the noise level and do not affect the measurement. This measurement technique has been accepted by the Audio Engineering Society, AES17-1991, and the Electronic Industries Association of Japan, EIAJ CP-307.

Interchannel Isolation

A measure of crosstalk between the left and right channels. Measured for each channel at the converter's output with all zeros to the input under test and a full-scale signal applied to the other channel. Units in decibels.

Interchannel Gain Mismatch

The gain difference between left and right channels. Units in decibels.

Gain Drift

The change in gain value with temperature. Units in ppm/°C.

7. PACKAGE INFORMATION

7.1 Dimensions

14L SOIC (150 MIL BODY) PACKAGE DRAWING

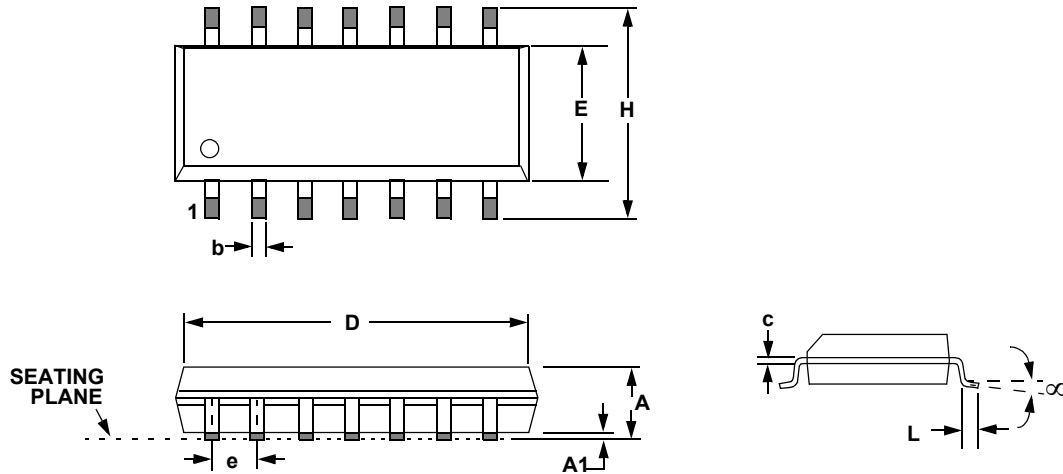

DIM	INCHES			MILLIMETERS		
	MIN	NOM	MAX	MIN	NOM	MAX
A	0.0590	-	0.0708	1.397	-	1.549
A1	0.0040	-	0.0098	0.102	-	0.249
b	0.0138	-	0.0200	0.351	-	0.508
C	0.0075	-	0.0098	0.190	-	0.250
D	0.3380	-	0.3440	8.585	-	8.738
E	0.1520	-	0.1574	3.861	-	3.998
e	-	0.050 BSC	-	-	1.270 BSC	-
H	0.2300	-	0.2440	5.842	-	6.198
L	0.0160	-	0.0350	0.406	-	0.889
α	0°	-	8°	0°	-	8°

JEDEC #: MS-012

Controlling Dimension is Millimeters

7.2 Thermal Characteristics

Parameter		Symbol	Min	Typ	Max	Units
Junction to Ambient Thermal Impedance	2 Layer Board	θ_{JA}	-	110	-	°C/Watt
	4 Layer Board		-	86	-	

8. ORDERING INFORMATION

Product	Description	Package	Pb-Free	Grade	Temp Range	Container	Order #
CS4354	5 V Stereo Audio DAC with 2 V _{RMS} Line Output	14-pin SOIC	YES	Commercial	-40° to +85° C	Rail	CS4354-CSZ
						Tape & Reel	CS4354-CSZR
CDB4354	CS4354 Evaluation Board		-	-	-	-	CDB4354

9. REVISION HISTORY

Release	Changes
A1 (Sept '09)	– Initial release.
A2 (July '10)	<ul style="list-style-type: none"> – Updated THD+N specification in DAC Analog Characteristics. – Updated dynamic range specification in DAC Analog Characteristics. – Updated idle channel noise/SNR specification in DAC Analog Characteristics. – Updated front page dynamic range and THD+N performance to match updated specifications. – Updated frequency response specification description in Combined Digital and On-Chip Analog Filter Characteristics so that frequency response limits are measured relative to 1 kHz. – Updated Power On Reset threshold values in Internal Power-On Reset Threshold Voltages. – Removed typical specification for LRCK and SCLK in Switching Specifications - Serial Audio Interface. – Updated power supply current specifications in DC Electrical Characteristics. – Updated pin voltage specification in DC Electrical Characteristics. – Corrected MCLK frequency in Table 4 from 33.8680 MHz to 33.8688 MHz. – Updated test condition bandwidth in DAC Analog Characteristics from 10 Hz - 20kHz to 20 Hz - 20kHz – Removed MCLK = 1152x LRCK mode support (per Rev B0 silicon). Updated specifications (LRCK min and corresponding MCLK min) in Switching Specifications - Serial Audio Interface, and applications information in Table 4 and Table 5. – Added (Note 16) to DC Electrical Characteristics. – Updated FILT+ description in Initialization. – Updated interchannel isolation specification in DAC Analog Characteristics. – Updated Table 3 to match specifications in Switching Specifications - Serial Audio Interface. – Removed High Pass Filter Characteristics section; appended updated specifications to Combined Digital and On-Chip Analog Filter Characteristics. – Updated passband and stopband specifications in Combined Digital and On-Chip Analog Filter Characteristics to reflect Rev B0 silicon. – Updated title and plots in Combined Digital and On-chip Analog Filter Response Plots to reflect Rev B0 silicon. – Updated typical output offset in DAC Analog Characteristics. – Updated timing diagram Figure 2 to reflect internal SCLK generation as shown in Figure 3. – Updated Typical Connection Diagram; VL capacitor now recommended by default.

Contacting Cirrus Logic Support

For all product questions and inquiries, contact a Cirrus Logic Sales Representative.

To find one nearest you, go to www.cirrus.com.

IMPORTANT NOTICE

"Advance" product information describes products that are in development and subject to development changes. Cirrus Logic, Inc. and its subsidiaries ("Cirrus") believe that the information contained in this document is accurate and reliable. However, the information is subject to change without notice and is provided "AS IS" without warranty of any kind (express or implied). Customers are advised to obtain the latest version of relevant information to verify, before placing orders, that information being relied on is current and complete. All products are sold subject to the terms and conditions of sale supplied at the time of order acknowledgment, including those pertaining to warranty, indemnification, and limitation of liability. No responsibility is assumed by Cirrus for the use of this information, including use of this information as the basis for manufacture or sale of any items, or for infringement of patents or other rights of third parties. This document is the property of Cirrus and by furnishing this information, Cirrus grants no license, express or implied under any patents, mask work rights, copyrights, trademarks, trade secrets or other intellectual property rights. Cirrus owns the copyrights associated with the information contained herein and gives consent for copies to be made of the information only for use within your organization with respect to Cirrus integrated circuits or other products of Cirrus. This consent does not extend to other copying such as copying for general distribution, advertising or promotional purposes, or for creating any work for resale.

CERTAIN APPLICATIONS USING SEMICONDUCTOR PRODUCTS MAY INVOLVE POTENTIAL RISKS OF DEATH, PERSONAL INJURY, OR SEVERE PROPERTY OR ENVIRONMENTAL DAMAGE ("CRITICAL APPLICATIONS"). CIRRUS PRODUCTS ARE NOT DESIGNED, AUTHORIZED OR WARRANTED FOR USE IN PRODUCTS SURGICALLY IMPLANTED INTO THE BODY, AUTOMOTIVE SAFETY OR SECURITY DEVICES, LIFE SUPPORT PRODUCTS OR OTHER CRITICAL APPLICATIONS. INCLUSION OF CIRRUS PRODUCTS IN SUCH APPLICATIONS IS UNDERSTOOD TO BE FULLY AT THE CUSTOMER'S RISK AND CIRRUS DISCLAIMS AND MAKES NO WARRANTY, EXPRESS, STATUTORY OR IMPLIED, INCLUDING THE IMPLIED WARRANTIES OF MERCHANTABILITY AND FITNESS FOR PARTICULAR PURPOSE, WITH REGARD TO ANY CIRRUS PRODUCT THAT IS USED IN SUCH A MANNER. IF THE CUSTOMER OR CUSTOMER'S CUSTOMER USES OR PERMITS THE USE OF CIRRUS PRODUCTS IN CRITICAL APPLICATIONS, CUSTOMER AGREES, BY SUCH USE, TO FULLY INDEMNIFY CIRRUS, ITS OFFICERS, DIRECTORS, EMPLOYEES, DISTRIBUTORS AND OTHER AGENTS FROM ANY AND ALL LIABILITY, INCLUDING ATTORNEYS' FEES AND COSTS, THAT MAY RESULT FROM OR ARISE IN CONNECTION WITH THESE USES.

Cirrus Logic, Cirrus, and the Cirrus Logic logo designs are trademarks of Cirrus Logic, Inc. All other brand and product names in this document may be trademarks or service marks of their respective owners.

Blu-Ray Disc is a registered trademark of SONY KABUSHIKI KAISHA CORPORATION.