

**Features**

- Optocoupler, Precision Reference, and Error Amplifier in a Single Package
- 1.240V ± 1% Reference (@ 25°C)
- Linear Optical Coupler Technology with an Industry Standard 431-type
- CTR 300% to 600% Linearity
- 3750V<sub>rms</sub> Isolation

**Applications**

- Power System for Workstations
- Telecom Central Office Supply
- Telecom Bricks

**Block Diagram**

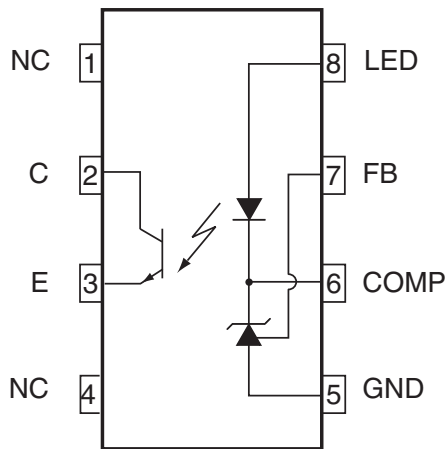

**Description**

The LIA130 is an optically isolated amplifier with a 431-type precision programmable shunt reference combined in the same package. The optocoupler portion of the LIA130 comprises a Gallium Arsenide (GaAs) light-emitting diode (LED) optically coupled to a silicon phototransistor. The current transfer ratio of the device is between 300% and 600%.

The combination of features in the LIA130 is optimal for use in isolated AC-to-DC power supplies and DC-to-DC converters. It replaces several discrete components, saves valuable circuit board space, and reduces complexity.

The device is available in DIP and surface-mount packages.

**Approvals**

- UL Recognized Component: File # E76270
- CSA Certified Component: Certificate # 1305490

**Ordering Information**

Part #	Description
LIA130	8 Pin DIP (50/Tube)
LIA130S	8-Pin Surface Mount (50/Tube)
LIA130STR	8-Pin Surface Mount (1000/Reel)



### Absolute Maximum Ratings (@ 25° C)

Parameter	Symbol	Ratings	Units
Collector-Emitter Voltage	$V_{CEO}$	20	V
Emitter-Collector Voltage	$V_{ECO}$	7	V
Input Voltage	$V_{LED}$	10	V
Input DC Current	$I_{LED}$	20	mA
Collector Current	$I_C$	50	mA
Input Power Dissipation <sup>1</sup>	$P_D$	145	mW
Transistor Power Dissipation <sup>2</sup>	$P_D$	85	mW
Total Power Dissipation <sup>3</sup>	$P_D$	145	mW
Storage Temperature	$T_{STG}$	-55 to +125	°C
Operating Temperature	$T_{OPR}$	-40 to +85	°C

<sup>1</sup> Derate linearly from 25°C at a rate of 2.42 mW/°C.

<sup>2</sup> Derate linearly from 25°C at a rate of 1.42 mW/°C.

<sup>3</sup> Derate linearly from 25°C at a rate of 2.42 mW/°C.

Absolute Maximum Ratings are stress ratings. Stresses in excess of these ratings can cause permanent damage to the device. Functional operation of the device at conditions beyond those indicated in the operational sections of this data sheet is not implied.

### Electrical Characteristics

Parameter	Conditions	Symbol	Min	Typ	Max	Units
<b>Input Characteristics @ 25°C</b>						
LED forward voltage	$I_{LED} = 5 \text{ mA}, V_{COMP} = V_{FB}$ (Fig.1)	$V_F$	0.9	-	1.4	V
Reference voltage	$V_{COMP} = V_{FB}, I_{LED} = 10 \text{ mA}, -40 \text{ to } +85^\circ\text{C}$ (Fig.1)	$V_{REF}$	1.224	1.24	1.259	V
	$V_{COMP} = V_{FB}, I_{LED} = 10 \text{ mA}, 25^\circ\text{C}$ (Fig.1)		1.228	1.24	1.252	
Deviation of $V_{REF}$ over temperature <sup>1</sup>	$T_A = -40 \text{ to } +85^\circ\text{C}$	$V_{REF(DEV)}$	-	77	TBD	mV
Ratio of $V_{REF}$ variation to the output of the error amplifier	$I_{LED} = 10 \text{ mA}, V_{COMP} = V_{REF}$ to 10 V (Fig.2)	$\frac{\Delta V_{REF}}{\Delta V_{COMP}}$	-	0.002	TBD	mV/V
Feedback input current	$I_{LED} = 10 \text{ mA}, R1 = 10 \text{ k}\Omega$ (Fig.3)	$I_{REF}$	-	0.09	TBD	$\mu\text{A}$
Deviation of $I_{REF}$ over temperature <sup>1</sup>	$T_A = -40 \text{ to } +85^\circ\text{C}$	$I_{REF(DEV)}$	-	0.028	TBD	$\mu\text{A}$
Minimum drive current	$V_{COMP} = V_{FB}$ (Fig.1)	$I_{LED(MIN)}$	-	45	80	$\mu\text{A}$
Off-state error amplifier current	$V_{LED} = 6 \text{ V}, V_{FB} = 0$ (Fig.4)	$I_{(OFF)}$	-	0.001	0.1	$\mu\text{A}$
Error amplifier output impedance <sup>2</sup>	$V_{COMP} = V_{FB}, I_{LED} = 0.1 \text{ mA to } 15 \text{ mA}, f < 1 \text{ kHz}$	$ Z_{OUT} $	-	0.22	-	$\Omega$
<b>Output Characteristics @ 25°C</b>						
Collector dark current	$V_{CE} = 10 \text{ V}$ (Fig. 5)	$I_{CEO}$	-	0.3	50	nA
Collector-emitter voltage breakdown	$I_C = 1.0 \text{ mA}$	$BV_{CEO}$	70	-	-	V
Emitter-collector voltage breakdown	$I_E = 100 \mu\text{A}$	$BV_{ECO}$	7	-	-	V

1. The deviation parameters  $V_{REF(DEV)}$  and  $I_{REF(DEV)}$  are defined as the differences between the maximum and minimum values obtained over the rated temperature range. The average full-range temperature coefficient of the reference input voltage,  $\Delta V_{REF}$  is defined as:

$$|\Delta V_{REF}| (\text{ppm}/^\circ\text{C}) = (V_{REF(DEV)}/V_{REF}(T_A, 25^\circ\text{C})) \times 10^6 / \Delta T_A$$

where  $\Delta T_A$  is the rated operating free-air temperature range of the device.

2. The dynamic impedance is defined as  $|Z_{OUT}| = \Delta V_{COMP}/\Delta I_{LED}$ . When the device is operating with two external resistors (see Figure 2), the total dynamic impedance of the circuit is given by:

$$|Z_{OUT, TOT}| = \Delta V/\Delta I \approx |Z_{OUT}| \times [1 + R1/R2]$$

**Electrical Characteristics**

Parameter	Conditions	Symbol	Min	Typ	Max	Units
<b>Transfer Characteristics @ 25°C</b>						
Current transfer ratio	$I_{LED} = 5 \text{ mA}, V_{COMP} = V_{FB}, V_{CE} = 5 \text{ V}$ (Fig. 6)	CTR	300	500	600	%
Collector-emitter saturation voltage	$I_{LED} = 10 \text{ mA}, V_{COMP} = V_{FB}, I_C = 2.5 \text{ mA}$ (Fig. 6)	$V_{CE(SAT)}$	-	0.099	0.5	V
<b>Isolation Characteristics @ 25°C</b>						
Input-output insulation leakage current <sup>1</sup>	$RH = 45\%, T_A = 25^\circ\text{C}, t = 5\text{s}, V_{I-O} = 3000 \text{ V}_{DC}$	$I_{I-O}$	-	-	1.0	$\mu\text{A}$
Withstand insulation voltage <sup>1</sup>	$RH \leq 50\%, T_A = 25^\circ\text{C}, t = 1 \text{ min}$	$V_{ISO}$	2500	-	-	$V_{rms}$
Resistance (input to output) <sup>1</sup>	$V_{I-O} = 500 \text{ V}_{DC}$	$R_{I-O}$	-	$10^{12}$	-	$\Omega$
<b>Switching Characteristics @ 25°C</b>						
Bandwidth	(Fig. 7)	$B_W$	-	10	-	kHZ
Common mode transient immunity at output high <sup>2</sup>	$I_{LED} = 0 \text{ mA}, V_{cm} = 10 \text{ V}_{PP}, R_L = 2.2 \text{ k}\Omega$ (Fig. 8)	$ CMH $	-	TBD	-	$\text{kV}/\mu\text{s}$
Common mode transient immunity at output low <sup>2</sup>	$I_{LED} = 10 \text{ mA}, V_{cm} = 10 \text{ V}_{PP}, R_L = 2.2 \text{ k}\Omega$ (Fig. 8)	$ CML $	-	TBD	-	$\text{kV}/\mu\text{s}$

1. Device is considered as a two terminal device: Pins 1, 2, 3 and 4 are shorted together and Pins 5, 6, 7 and 8 are shorted together.

2. Common mode transient immunity at output high is the maximum tolerable (positive)  $dV_{cm}/dt$  on the leading edge of the common mode impulse signal,  $V_{cm}$ , to assure that the output will remain high. Common mode transient immunity at output low is the maximum tolerable (negative)  $dV_{cm}/dt$  on the trailing edge of the common pulse signal,  $V_{cm}$ , to assure that the output will remain low.

**Example Application for the LIA130**

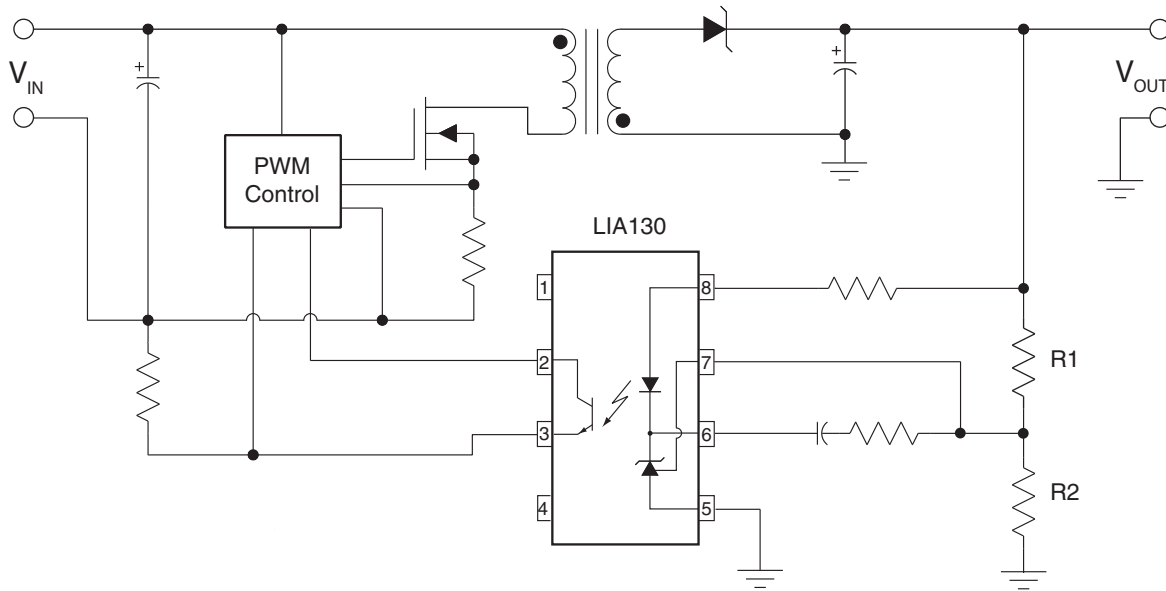

Test Circuits

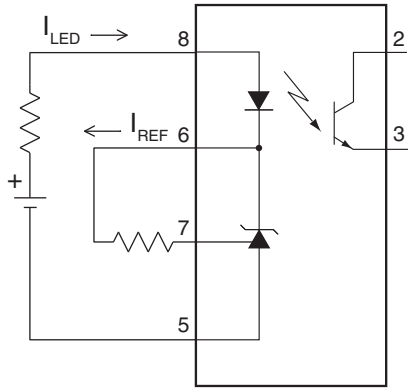

$I_{REF}$  Test Circuit

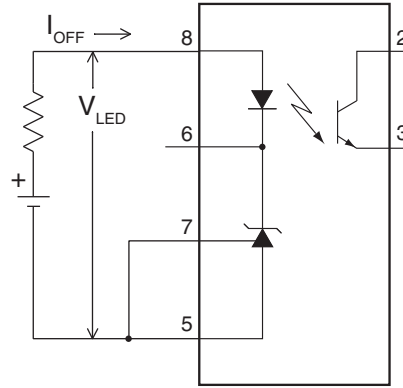

$I_{OFF}$  Test Circuit

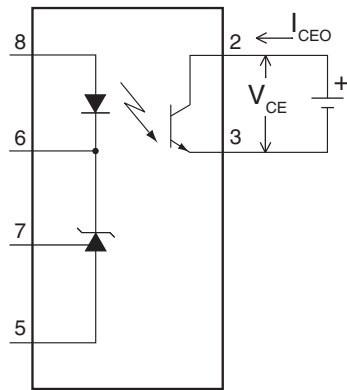

$I_{CEO}$  Test Circuit

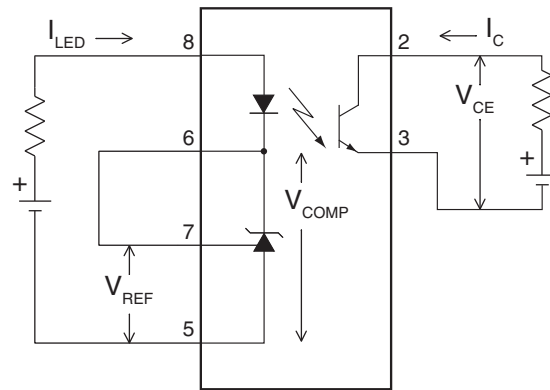

CTR,  $V_{CE-sat}$  Test Circuit

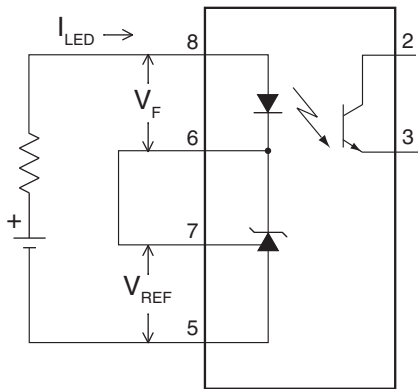

$V_{REF}$ ,  $V_F$ ,  $I_{LED-min}$  Test Circuit

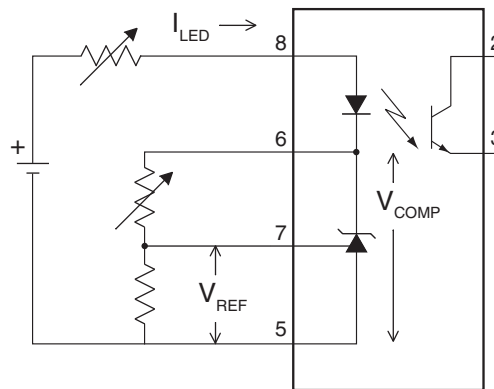

$\Delta V_{REF} / \Delta V_{COMP}$  Test Circuit

Test Circuits (cont.)

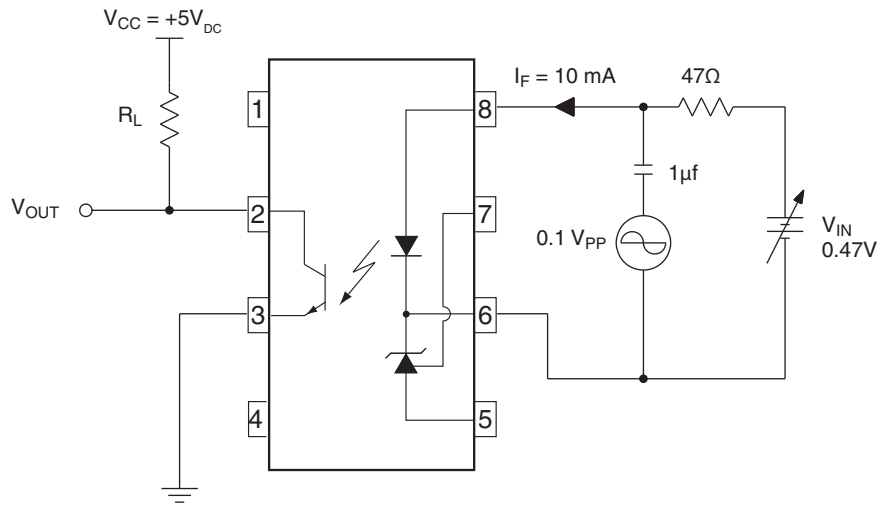

Frequency Response

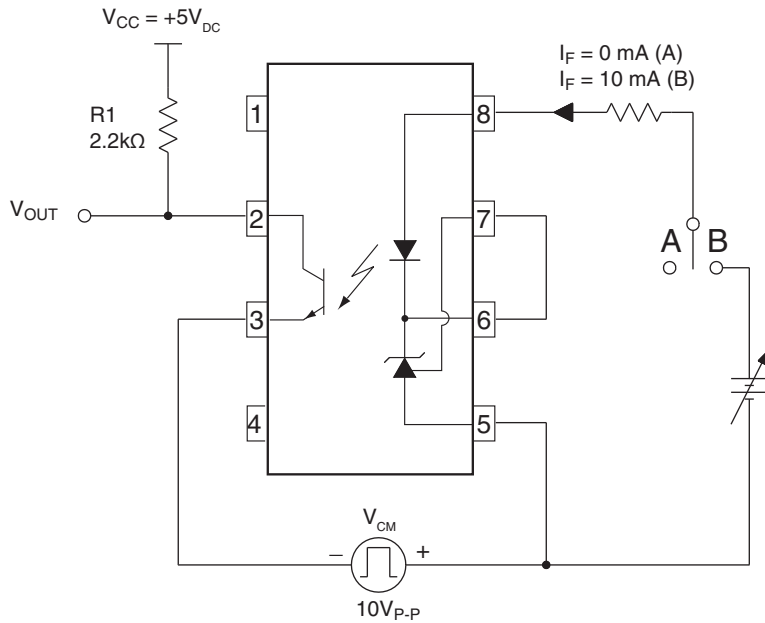

CMH and CML

PERFORMANCE DATA\*

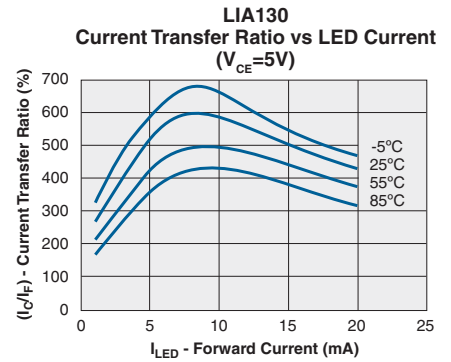
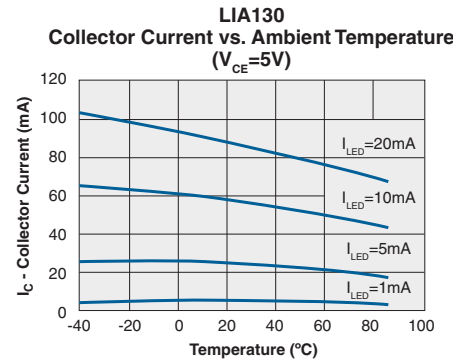
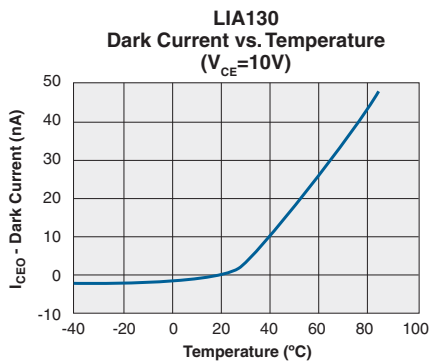
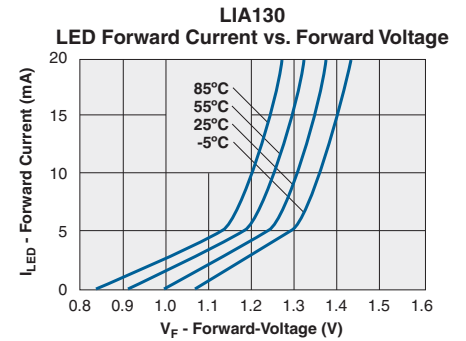
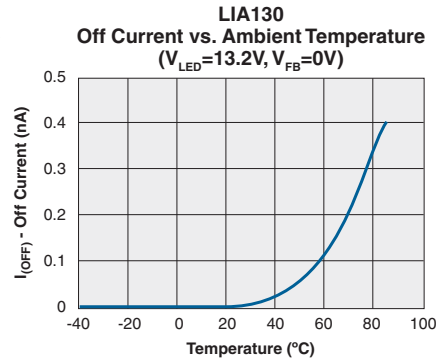
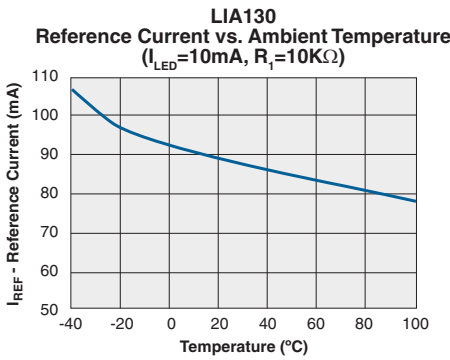
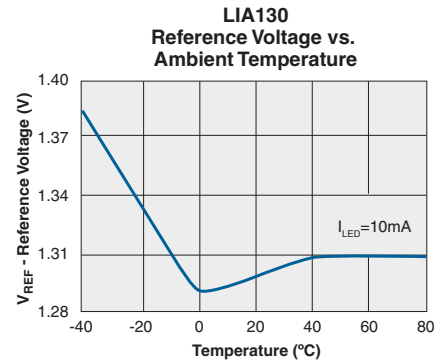
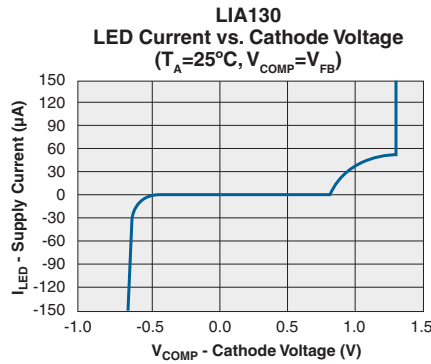
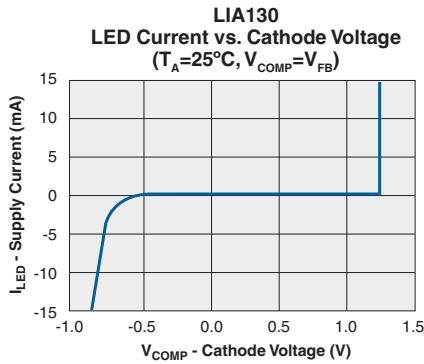

\*The Performance data shown in the graphs above is typical of device performance. For guaranteed parameters not indicated in the written specifications, please contact our application department.

**PERFORMANCE DATA\***

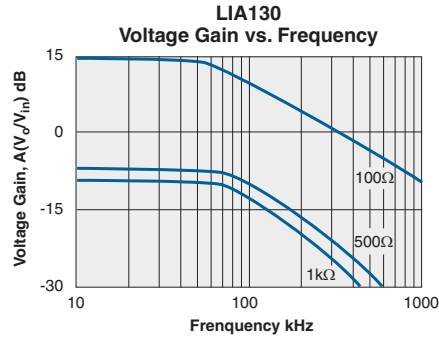
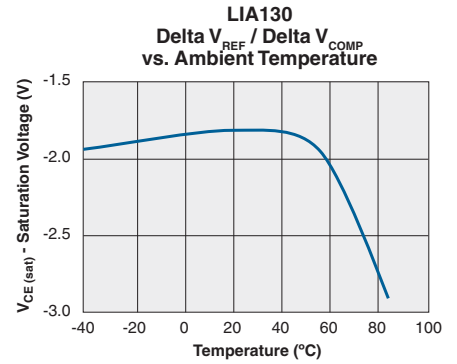
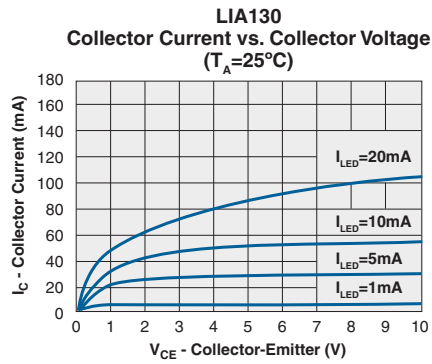
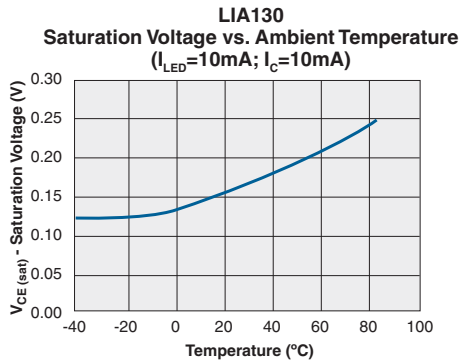

\*The Performance data shown in the graphs above is typical of device performance. For guaranteed parameters not indicated in the written specifications, please contact our application department.

### The LIA130

The LIA130 is essentially an optically isolated error amplifier. It comprises three of the necessary components to form an isolated power supply: an optocoupler, an error amplifier, and a reference voltage device. The LIA130 is the functional equivalent of a 431 series shunt voltage regulator plus an optocoupler in the same package.

### LED Pin

The LED within the LIA130 is powered by a sample of the output voltage that is being regulated. Typically, a resistor divider is provided to keep this voltage sample within the operating range of the LED and its series resistor. As the output voltage changes, the LED light output changes, which provides a changing error voltage from the phototransistor output of the LIA130. The sampled voltage must be at least 1.24V (the reference voltage) plus 1.5V (the LED voltage drop) or a minimum of 2.74 volts. The sampled voltage can also be provided from a slaved secondary winding of the transformer rather than a resistor divider.

There must be a current-limiting resistor in series with the LED pin to keep the current flow through the LED within its operating range for all expected sampled output levels. This resistor must be selected along with the resistor in series with the output phototransistor.

### FB Pin

The LIA130, when connected as shown in the Typical Application Circuit, will regulate the output voltage so that the voltage on its FB pin is 1.24V. Set the values of the two voltage divider resistors, R1 and R2 in this way:

$$R1/R2 = (V_{OUT} / V_{REF}) - 1$$

The value of R1 is set by the input offset current, 0.8 $\mu$ A. 1% accuracy is obtained when the value of R1 satisfies this formula:

$$((V_{OUT} - 1.24) / R1) > 80\mu A$$

### GND Pin

Connect the GND pin of the LIA130 to the secondary ground of the converter.

### NC Pins

The NC (not connected) pins have no internal connection and must not have any connection to the secondary side, as this might compromise the primary-to-secondary isolation.

### COMP Pin

The frequency response of the converter can be optimized for the particular application by placing a compensation network between the COMP pin and the FB pin of the LIA130. In a system with a typical low-bandwidth requirement, only a 0.1 $\mu$ F capacitor might be needed.

If the system has more critical bandwidth requirements, then measurements must be made of the system's loop. See "Practical Design of Power Supplies" by Ron Lenk, IEEE Press, 1998, for an excellent description.

### C & E Pins

The output phototransistor of the LIA130 provides the isolated and amplified error signal that represents the DC output level of the converter. Typically, the collector of the phototransistor will be pulled up to voltage and the emitter will be grounded.

The value of the collector's pull-up resistor and the value of the LED current-limiting resistor must be determined together with respect to the input voltage range of the PWM circuitry. The variation in CTR of the LIA130 must also be taken into account.

As an example, consider first that the minimum CTR of the LIA130 is 300%. If the current-limiting resistor of the LED is set to allow a maximum current through the LED of 1mA when the converter output is at a nominal 15 volts:

$$R_{LED} = (15V - 2.74V) / 0.001A = 12.260k\Omega$$

then a minimum of 3mA will flow through the collector pull-up resistor. If the collector is pulled up to 12V and the PWM has an internal reference voltage of 5V, then the minimum resistor value is:

$$R_{PULLUP} > (12V - 5V) / 0.003A > 2.333k\Omega$$

[Standard values can be selected for  $R_{LED}$  and  $R_{PULLUP}$  and the small differences then re-calculated.]



**MANUFACTURING INFORMATION**

**Soldering**

For proper assembly, the component must be processed in accordance with the current revision of IPC/JEDEC standard J-STD-020. Failure to follow the recommended guidelines may cause permanent damage to the device resulting in impaired performance and/or a reduced lifetime expectancy.

**Washing**

Clare does not recommend ultrasonic cleaning or the use of chlorinated solvents.



**MECHANICAL DIMENSIONS**

**8-Pin DIP Through-Hole Package**

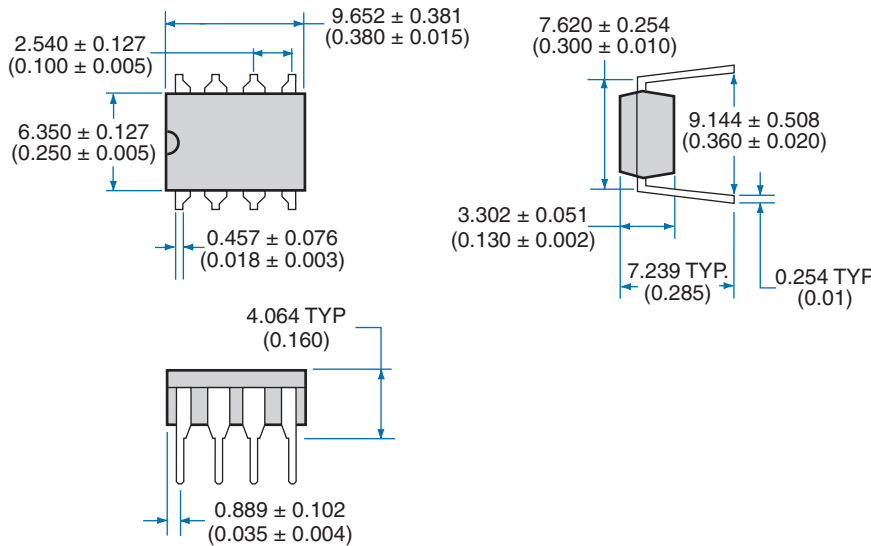

**PC Board Pattern**

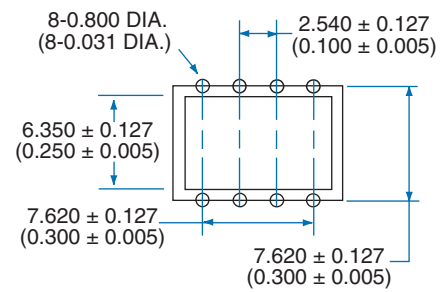

Dimensions  
mm  
(inches)

**8-Pin Surface Mount Package**

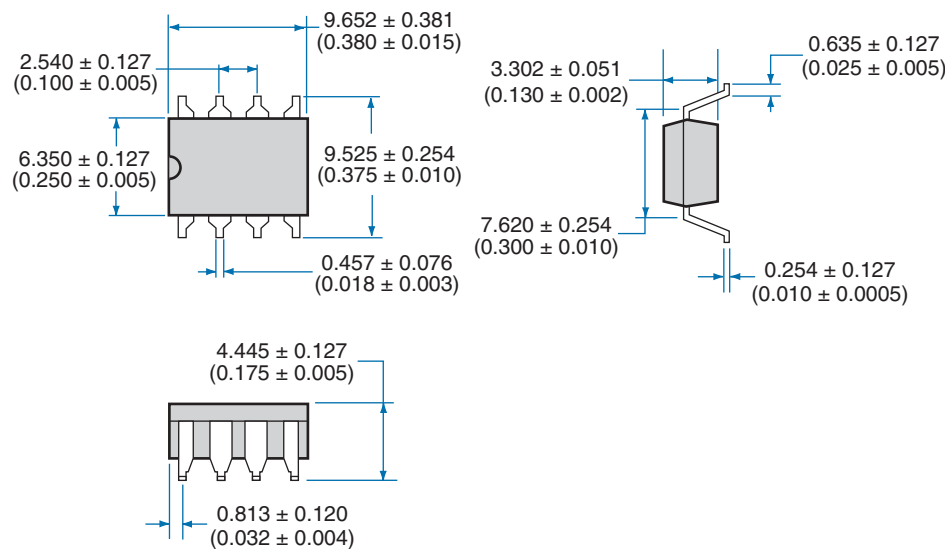

**Recommended PCB Land Pattern**

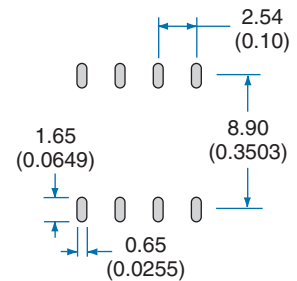

Dimensions  
mm  
(inches)

**MECHANICAL DIMENSIONS (Cont.)**

**Tape and Reel Packaging for 8-Pin Surface Mount Package**

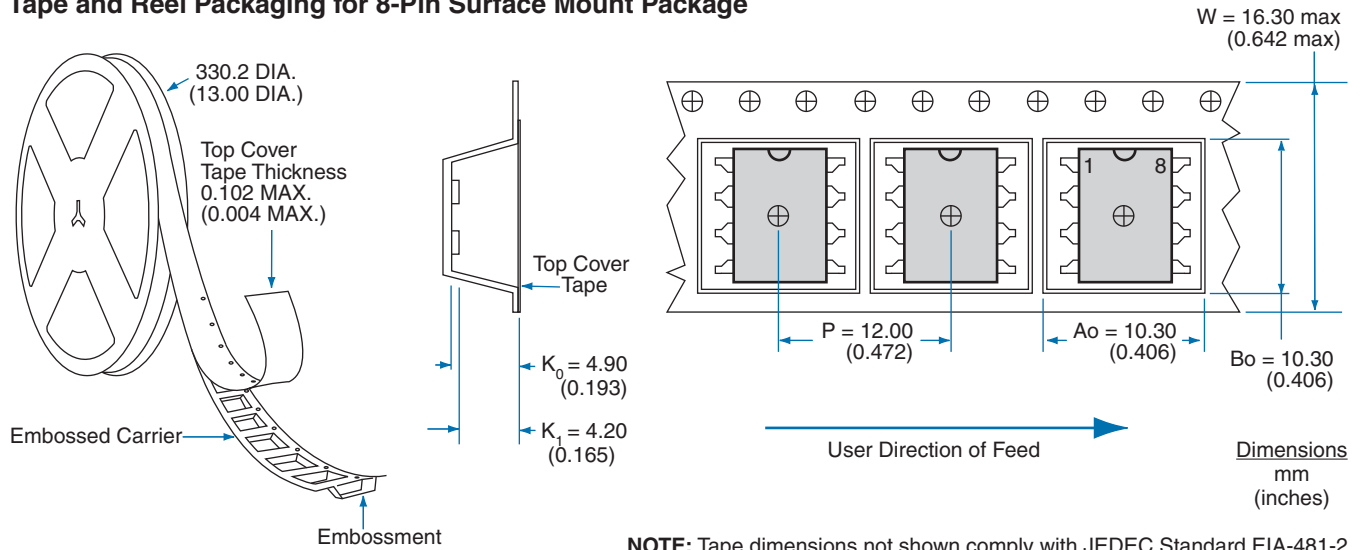

**NOTE:** Tape dimensions not shown comply with JEDEC Standard EIA-481-2

**For additional information please visit our website at: [www.clare.com](http://www.clare.com)**

Clare, Inc. makes no representations or warranties with respect to the accuracy or completeness of the contents of this publication and reserves the right to make changes to specifications and product descriptions at any time without notice. Neither circuit patent licenses nor indemnity are expressed or implied. Except as set forth in Clare's Standard Terms and Conditions of Sale, Clare, Inc. assumes no liability whatsoever, and disclaims any express or implied warranty, relating to its products including, but not limited to, the implied warranty of merchantability, fitness for a particular purpose, or infringement of any intellectual property right.

The products described in this document are not designed, intended, authorized or warranted for use as components in systems intended for surgical implant into the body, or in other applications intended to support or sustain life, or where malfunction of Clare's product may result in direct physical harm, injury, or death to a person or severe property or environmental damage. Clare, Inc. reserves the right to discontinue or make changes to its products at any time without notice.