

MB86H55/MB86H56

Ultra Low Power Full HD H.264 Codec

Introduction

The Fujitsu MB86H55, MB86H56 can compress and decompress full High-Definition (HD) video (1920 dots x 1080 lines) in the H.264 format in real-time.

The two products feature power consumption of only 500mW during Full HD encoding including the in-package memory, an industry-leading level for low power consumption. In addition, MB86H56 offers processing of Full HD video at 60p, to improve picture quality even further.

These two products have memory in-package to offer a small package size of 15mm x 15mm, thus making it ideal to record, play and transmit superior picture quality HD video on portable devices such as digital camcorders, as well as on home networked appliances, commercial broadcast equipment, and security cameras.

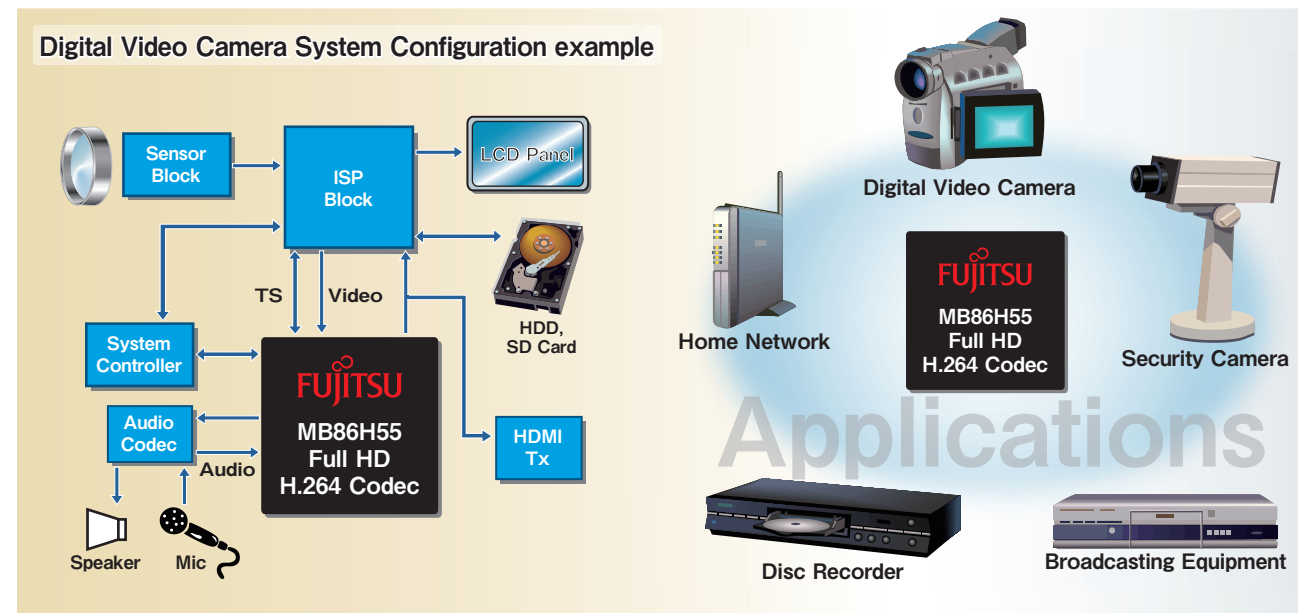

Features

- Small form-factor, low power consumption necessary for portable devices**
Both new products contain one 512M bit memory in-package. Due to the reduction in the number of memory chips, as well as the usage of 65nm process technology, the power consumption during Full HD encoding, including the in-package memory, is reduced to 500mW (at 60i). Also, it is provided in a small form-factor, 15mm x 15mm package.
- Processing at 60p further improves picture quality (MB86H56)**
The existing CODEC product, MB86H51, processes video at 30 frames per second(60i); while the new MB86H56 doubles this to 60 frames per second, 60p, to boost picture quality.
- Both LSIs feature embedded Up/Down scaler**
Both products have an embedded scaler for expansion or reduction of the picture. In units of 16 bit x 32 lines, pictures can be expand by a maximum of 6 times or reduced to 1/6.
- Improved connectivity to peripheral LSIs**
Both products contain many interfaces for improved connectivity. There is a 16 bit parallel interface and a TS interface as the video stream interface. In addition, there is a serial interface in which a reduction of pins for host interface is possible, as well as a PCI interface for connecting a PC or a recorder. Connection to external ROM is also possible, thus realizing high-speed boot for devices that feature this LSI.

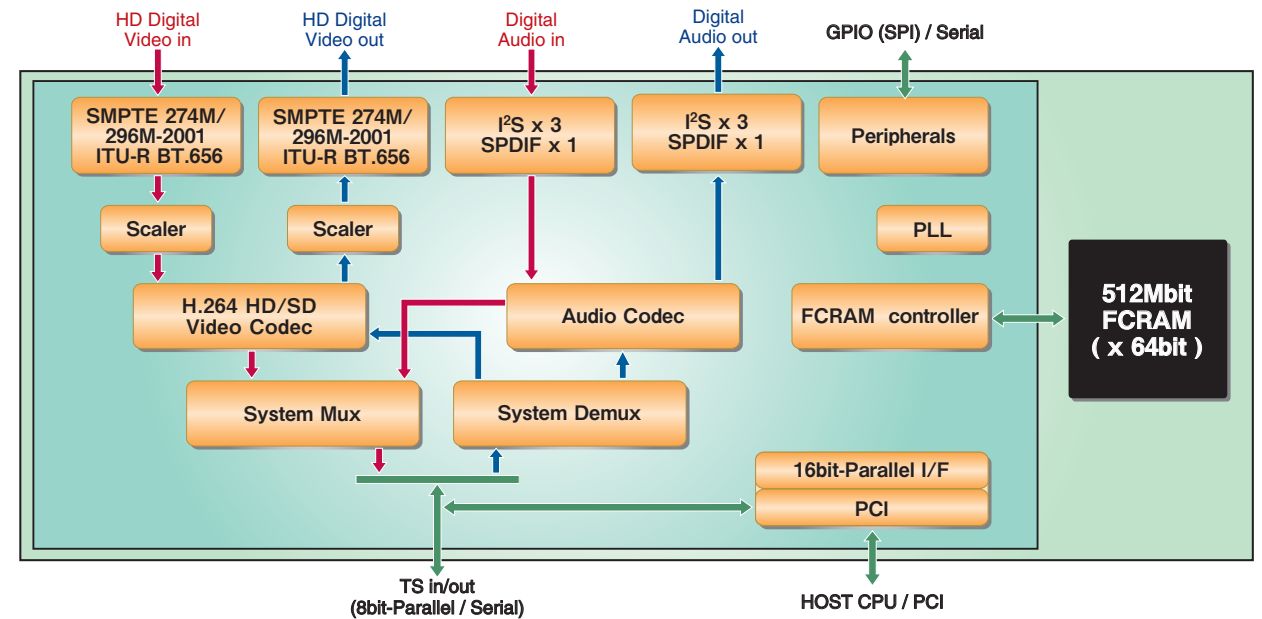

Specifications

Video	Profile	MB86H55 : H.264 High profile / Level 4.0 Half -Duplex Codec MB86H56 : H.264 High profile / Level 4.2*1 Half -Duplex Codec
Resolution		1920 x 1080 x 60p/50p (MB86H56 only), 1920 x 1080 x 60i/50i/30p/24p, 1440 x 1080 x 60i/50i/30p/24p, 1280 x 720 x 60p/50p, 720 x 480 x 60i, 720 x 576 x 50i Up/Down scaler embedded
Bit Rate		MB86H55 : 24Mbps(max.) , MB86H56 : 30Mbps(max.)
Interface		SMPTE 274M / SMPTE296M-2001, ITU-R BT.656, External sync mode (H/V/F + 16bit data)
Audio	Format	Dolby® Digital(AC-3)*2, MPEG-2/4 AAC(LC profile), MPEG-1 Audio Layer2, Linear PCM
	Channels	Max. 5.1 ch*3
	Interface	I ² S, S/PDIF
System	Format	ISO/IEC13818-1+Amd3(MPEG-2 TS), Video/Audio ES output
	Interface	8bit parallel, Serial, PCI
Host Interface		General 16bit parallel, Serial, PCI
Peripheral I/O		SPI
Input Clock Frequency		27MHz
Operating Frequency		MB86H55 : 108MHz (internal memory interface only: 135MHz) MB86H56 : 189MHz (internal memory interface only: 189MHz)
Power Consumption (including memory)		MB86H55 : 500mW (typ., 1.2V, 1920x1080x60i at encoding) MB86H56 : 850mW (typ., 1.2V, 1920x1080x60p at encoding)
Package		FBGA 650pin 15mm square SiP (Ball pitch 0.5mm)
Memory		512Mbit FCRAM x 1

*1 Support up to a maximum of 30Mbps bit rate.
*2 Dolby is a registered trademark of Dolby Laboratories.
*3 Number of channels depend on audio format.

FUJITSU MICROELECTRONICS LIMITED

Shinjuku Dai-ichi Seimei Bldg., 7-1, Nishishinjuku 2-chome, Shinjuku-ku, Tokyo 163-0722, Japan Tel: +81-3-5322-3347 Fax: +81-3-5322-3387
<http://jp.fujitsu.com/fml/en/>

North and South America
FUJITSU MICROELECTRONICS AMERICA, INC.
1250 E. Arques Avenue, M/S 333
Sunnyvale, CA 94085-5401, U.S.A.
Tel: +1-408-737-5600 Fax: +1-408-737-5999
<http://www.fma.fujitsu.com/>

Europe
FUJITSU MICROELECTRONICS EUROPE GmbH
Pittlerstrasse 47, 63225 Langen,
Germany
Tel: +49-6103-690-0 Fax: +49-6103-690-122
<http://emea.fujitsu.com/microelectronics/>

Korea
FUJITSU MICROELECTRONICS KOREA LTD.
206 KOSMO TOWER, 1002 Daechi-Dong,
Gangnam-Gu, Seoul 135-280, Republic of Korea
Tel: +82-2-3484-7100 Fax: +82-2-3484-7111
<http://kr.fujitsu.com/fmk/>

Asia Pacific
FUJITSU MICROELECTRONICS ASIA PTE. LTD.
151 Lorong Chuan, #05-08 New Tech Park
556741 Singapore
Tel: +65-6281-0770 Fax: +65-6281-0220
<http://www.fujitsu.com/sg/services/micro/semiconductor/>

FUJITSU MICROELECTRONICS SHANGHAI CO., LTD.
Rm. 3102, Bund Center, No.222 Yan An Road (E),
Shanghai 200002, China
Tel: +86-21-6146-3688 Fax: +86-21-6335-1605
<http://cn.fujitsu.com/fmc/>

FUJITSU MICROELECTRONICS PACIFIC ASIA LTD.
10/F., World Commerce Centre, 11 Canton Road
Tsimshatsui, Kowloon, Hong Kong
Tel: +852-2377-0226 Fax: +852-2376-3269
<http://cn.fujitsu.com/fmc/en/>

Specifications are subject to change without notice. For further information please contact each office.

All Rights Reserved.

The contents of this document are subject to change without notice. Customers are advised to consult with sales representatives before ordering. The information, such as descriptions of function and application circuit examples, in this document are presented solely for the purpose of reference to show examples of operations and uses of FUJITSU MICROELECTRONICS device; FUJITSU MICROELECTRONICS does not warrant proper operation of the device with respect to use based on such information. When you develop equipment incorporating the device based on such information, you must assume any responsibility arising out of such use of the information. FUJITSU MICROELECTRONICS assumes no liability for any damages whatsoever arising out of the use of the information. Any information in this document, including descriptions of function and schematic diagrams, shall not be construed as license of the use or exercise of any intellectual property right, such as patent right or copyright, or any other right of FUJITSU MICROELECTRONICS or any third party or does FUJITSU MICROELECTRONICS warrant non-infringement of any third-party's intellectual property right or other right by using such information. FUJITSU MICROELECTRONICS assumes no liability for any infringement of the intellectual property rights or other rights of third parties which would result from the use of information contained herein. The products described in this document are designed, developed and manufactured as contemplated for general use, including without limitation, ordinary industrial use, general office use, personal use, and household use, but are not designed, developed and manufactured as contemplated (1) for use accompanying fatal risks or dangers that, unless extremely high safety is secured, could have a serious effect to the public, and could lead directly to death, personal injury, severe physical damage or other loss (i.e., nuclear reaction control in nuclear facility, aircraft flight control, air traffic control, mass transport control, medical life support system, missile launch control in weapon system), or (2) for use requiring extremely high reliability (i.e., submersible repeater and artificial satellite). Please note that FUJITSU MICROELECTRONICS will not be liable against you and/or any third party for any claims or damages arising in connection with above-mentioned uses of the products. Any semiconductor devices have an inherent chance of failure. You must protect against injury, damage or loss from such failures by incorporating safety design measures into your facility and equipment such as redundancy, fire protection, and prevention of over-current levels and other abnormal operating conditions. Exportation/release of any products described in this document may require necessary procedures in accordance with the regulations of the Foreign Exchange and Foreign Trade Control Law of Japan and/or US export control laws. The company names and brand names herein are the trademarks or registered trademarks of their respective owners.