

PLEASE CHECK WWW.MOLEX.COM FOR LATEST PART INFORMATION

Part Number: [0190850005](#)
Status: **Active**
Description: Open Barrel Ring , Tin-Plated Brass, for 14-18 AWG Wire, Stud Size 8 (M4)

Documents:

[Drawing \(PDF\)](#) [RoHS Certificate of Compliance \(PDF\)](#)
[Product Specification PS-19902-006 \(PDF\)](#)

Agency Certification

CSA LR18689
 UL E32244

General

Product Family Ring and Spade Terminals
 Series [19085](#)
 Crimp Quality Equipment Yes
 Mil-Spec N/A
 Product Name N/A
 Type Ring

Physical

Barrel Type Open
 Insulation None
 Material - Plating Mating Tin
 Packaging Type Reel
 Plating min: Mating (µin) 200
 Plating min: Mating (µm) 5
 Plating min: Termination (µin) 200
 Plating min: Termination (µm) 5
 Stud Size 8 (M4)
 Temperature Range - Operating 149°C
 Termination Interface: Style Crimp or Compression
 Wire Insulation Diameter N/A
 Wire Size AWG 14, 16, 18
 Wire Size mm² 0.80 - 2.00

Electrical

Voltage - Maximum 2000V

Material Info

Old Part Number RZ-4129-08

Reference - Drawing Numbers

Product Specification PS-19902-006
 Sales Drawing SD-19085-002

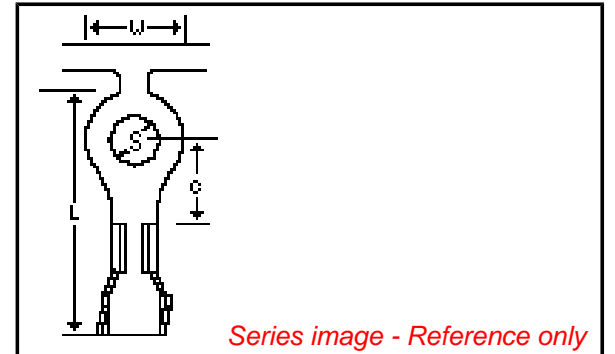

EU RoHS

ELV and RoHS Compliant
REACH SVHC
 Not Reviewed
Halogen-Free Status
Not Reviewed

China RoHS



Need more information on product environmental compliance?

Email productcompliance@molex.com
 For a multiple part number RoHS Certificate of Compliance, [click here](#)

Please visit the [Contact Us](#) section for any non-product compliance questions.

Search Parts in this Series

[19085Series](#)

Application Tooling | [FAQ](#)

Tooling specifications and manuals are found by selecting the products below. Crimp Height Specifications are then contained in the Application Tooling Specification document.

Global

Description	Product #
ASP Perishable Tool Kit used in ASP presses that process metal strip product	0190290053
Mini-Mac™ Applicator	0638815600

MATERIAL NUMBER	ENGINEERING NUMBER	STUD SIZE "S" ±.010/.(0.25)	MATERIAL	PLATING
190850001	19085-0001	#6 = .146/(3.71)	BRASS	NONE
190850002	19085-0002	#8 = .173/(4.39)	BRASS	NONE
190850003	19085-0003	#10 = .198/(5.03)	BRASS	NONE
190850004	RZ-4129-06	#6 = .146/(3.71)	BRASS	TIN
190850005	RZ-4129-08	#8 = .173/(4.39)	BRASS	TIN
190850006	RZ-4129-10	#10 = .198/(5.03)	BRASS	TIN
190850007	RZ-S-4129-06	#6 = .146/(3.71)	STEEL	TIN
190850008	RZ-S-4129-08	#8 = .173/(4.39)	STEEL	TIN
190850009	RZ-S-4129-10	#10 = .198/(5.03)	STEEL	TIN

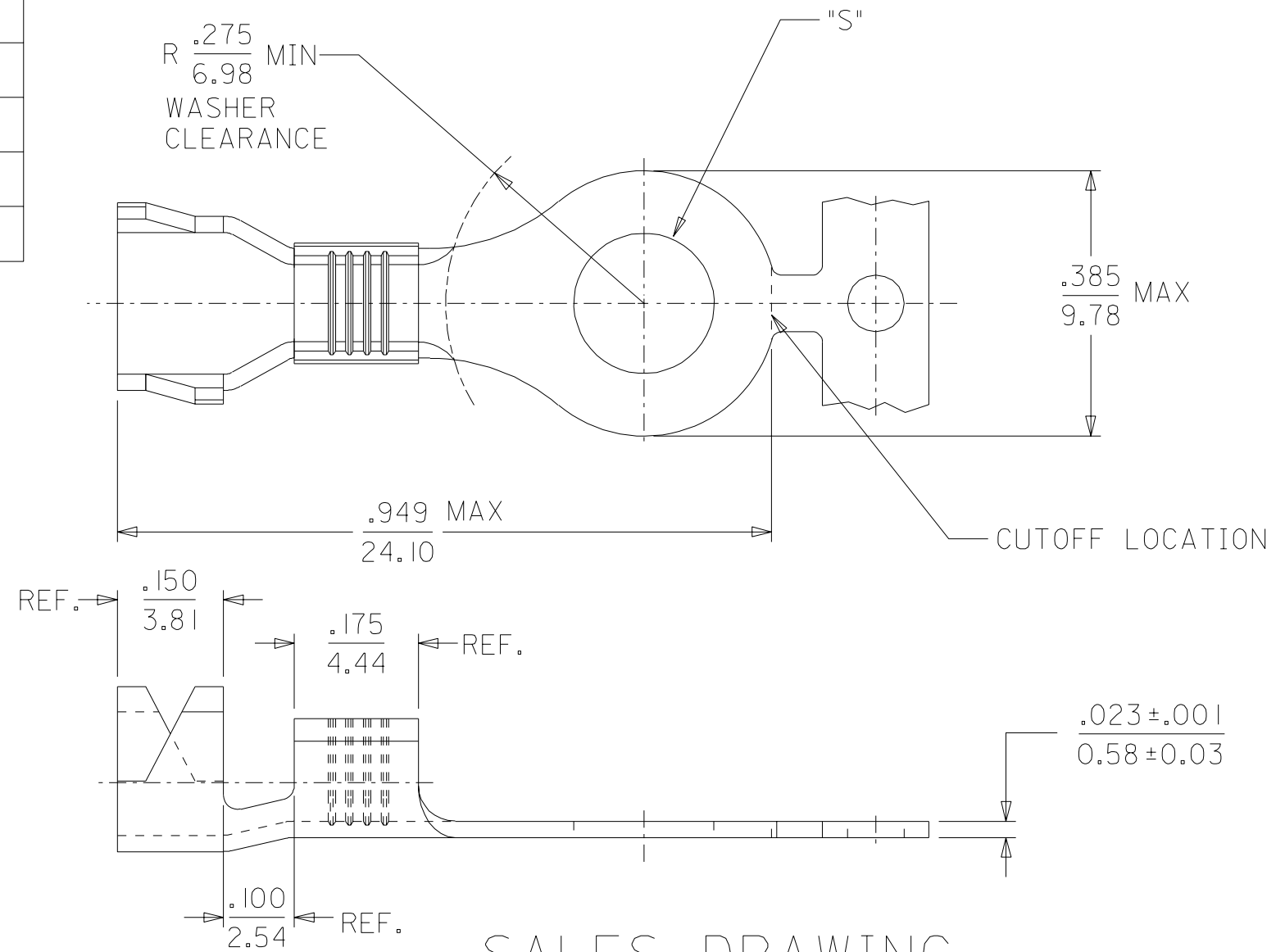

SALES DRAWING

- NOTES:
1. MATERIAL: SEE CHART.
 2. PLATING: SEE CHART.
 3. WIRE RANGE: 18-14 AWG/1.3-2.6 MM.²

WAS CD-4116 EC NO. ETC2002-0287 DRWN: BRE 02/04/10 CHK: HEB 02/04/10 APPR: RWD 02/04/10	QUALITY SYMBOLS	GENERAL TOLERANCES: (UNLESS SPECIFIED)		SCALE NO: NE	DESIGN UNITS <input type="checkbox"/> mm <input checked="" type="checkbox"/> INCH	THIRD ANGLE PROJECTION <input type="checkbox"/> mm <input checked="" type="checkbox"/> INCH <input type="checkbox"/> mm ONLY	SHT	REV
	MAJOR = 0	mm	INCH	DRAWN BY & DATE BRE 02/04/02		TITLE: VIBRAKRIMP STRIP RING TONGUE TERMINAL		
	CRITICAL = 0	4 PLACES ±0.	±.	CHECKED BY & DATE HEB 02/04/02		MOLEX INCORPORATED		
		3 PLACES ±0.	±.	APPROVED BY & DATE RWD 02/04/02		MATERIAL NO. SEE CHART	DRAWING NO. SD-19085-002	SHEET NO. 1 OF 1
	2 PLACES ±0.	±.	ANGULAR: ± 1/2 °		THIS DRAWING CONTAINS INFORMATION THAT IS PROPRIETARY TO MOLEX INCORPORATED AND SHOULD NOT BE USED WITHOUT WRITTEN PERMISSION.			
	1 PLACE ±0.	±.	DRAFT WHERE APPLICABLE MUST REMAIN WITHIN DIMENSIONS		SIZE B			