

## Data Sheet



### 1 Overview

#### 1.1 Features

- Delivers up to 6 A continuous and 7 A peak current
- Optimized for DC motor management applications
- Very low  $R_{DS\ ON}$  of typ. 150 m $\Omega$  @ 25 °C per switch
- Operates at supply voltages of up to 40V
- Overvoltage Protection against transients up to 45 V
- Outputs fully short circuit protected
- Standard SPI-Interface, daisy chain capability
- Adjustable chopper current regulation of up to 7 A
- Temperature monitor with prewarning, warning and shutdown
- Over- and Undervoltage-Lockout
- Open load detection
- Detailed load failure diagnosis by SPI
- Minimized power dissipation due to active free-wheeling
- Low EMI due to voltage slope regulation
- Very low current consumption (typ. 20  $\mu$ A @ 25 °C) in stand-by (Inhibit) mode
- Enhanced power PG-DSO-Package
- Green Product (RoHS compliant)
- AEC Qualified



PG-DSO-20-37

Type	Package
TLE 6209 R	PG-DSO-20-37

### Functional Description

The TLE 6209 R is an integrated power H-Bridge with D-MOS output stages for driving bidirectional loads such as DC-Motors. The design is based on Infineons Smart Power Technology SPT which allows bipolar, CMOS and power D-MOS devices on the same monolithic circuit.

Operation modes forward (cw), reverse (ccw) and brake are invoked by two control pins PWM and DIR. Protection and a reliable diagnosis of overcurrent, openload, short-circuit to ground, to the supply voltage or across the load are integrated. Detailed diagnostic

information is given via the 8 bit SPI status word. An integrated chopper current limitation limits the current e.g. to reduce power dissipation during mechanical block of a DC motor. Several device parameters can be set by the SPI control word. A three-level temperature monitoring with prewarning, warning and shutdown is included for controlled operation under critical power loss conditions. The full protection and diagnosis capability make the device suitable especially for safety relevant applications, e.g. in automotive ECUs.

## 1.2 Pin Configuration (top view)

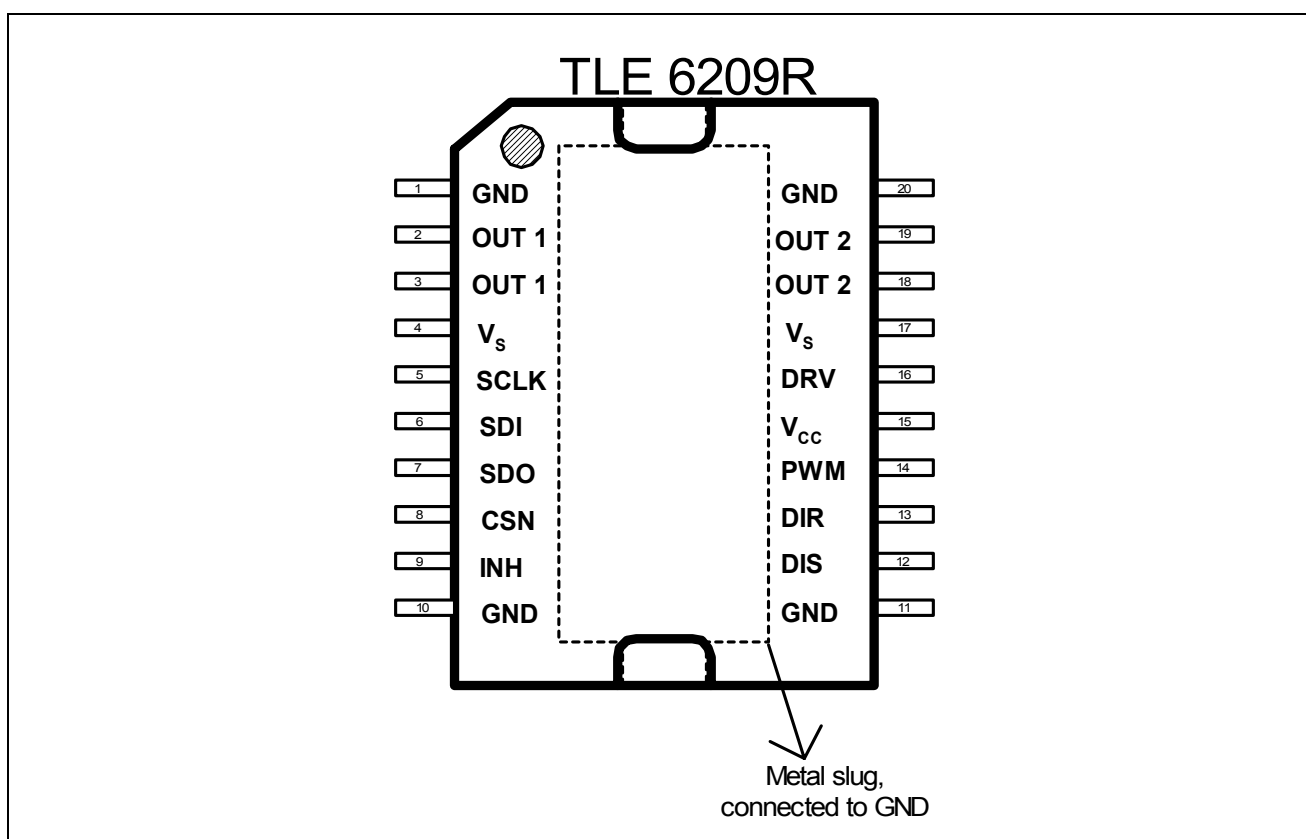

### Pin Definitions and Functions

V <sub>S</sub>	Power Supply Voltage	V <sub>CC</sub>	5 V Logic Supply
DRV	Input for Charge pump buffer capacitor	GND	Ground
SDI	Serial Data Input	SDO	Serial Data Output
SCLK	Serial Clock Input	CSN	Chip-Select-Not Input
OUT	Power Output	—	—
PWM	PWM Input	DIR	Direction Input
DIS	Disable Input	INH	Inhibit

### 1.2.1 Pin Definitions and Functions

Pin No.	Symbol	Function
1, 10, 11, 20	GND	<b>Ground</b> ; internally connected to cooling tab (heat slug); to reduce thermal resistance place cooling areas and thermal vias on PCB.
2,3	OUT1	<b>Output 1</b> ; output of D-MOS half bridge 1; external connection between pin 2 and pin 3 is necessary.
4,17	$V_S$	<b>Power supply</b> ; needs a blocking capacitor as close as possible to GND; 47 $\mu$ F electrolytic in parallel to 220 nF ceramic is recommended; external connection between pin 4 and pin 17 is necessary.
5	SCLK	<b>Serial clock input</b> ; clocks the shiftregister; SCLK has an internal active pull down and requires CMOS logic levels
6	SDI	<b>Serial data input</b> ; receives serial data from the control device; serial data transmitted to SDI is an 8 bit control word with the Least Significant Bit (LSB) being transferred first; the input has an active pull down and requires CMOS logic levels; SDI will accept data on the falling edge of SCLK-signal; see <b>Table 1</b> for input data protocol.
7	SDO	<b>Serial-Data-Output</b> ; this tri-state output transfers diagnosis data to the control device; the output will remain tri-stated unless the device is selected by a low on Chip-Select-Not (CSN); SDO state changes on the rising edge of SCLK; see <b>Table 4</b> for diagnosis protocol.
8	CSN	<b>Chip-Select-Not input</b> ; CSN is an active low input; serial communication is enabled by pulling the CSN terminal low; CSN input should only be transitioned when SCLK is low; CSN has an internal active pull up and requires CMOS logic levels.
9	INH	<b>Inhibit input</b> ; has an internal pull down; device is switched in standby condition by pulling the INH terminal low.
12	DIS	<b>Disable input</b> ; has an internal pull up; the output stages are switched in tristate condition by pulling the DIS terminal high.
13	DIR	<b>Direction input</b> ; has an internal pull down; TTL/CMOS compatible input.
14	PWM	<b>PWM input</b> ; has an internal pull down; TTL/CMOS compatible input.
15	$V_{CC}$	<b>Logic supply voltage</b> ; needs a blocking capacitor as close as possible to GND; 10 $\mu$ F electrolytic in parallel to 220 nF ceramic is recommended.

### 1.2.1 Pin Definitions and Functions (cont'd)

Pin No.	Symbol	Function
16	DRV	<b>Drive;</b> Input for external charge pump capacitor $C_{DRV}$
18,19	OUT2	<b>Output 2;</b> output of D-MOS half bridge 2; external connection between pin 2 and pin 3 is necessary.

### 1.3 Functional Block Diagram

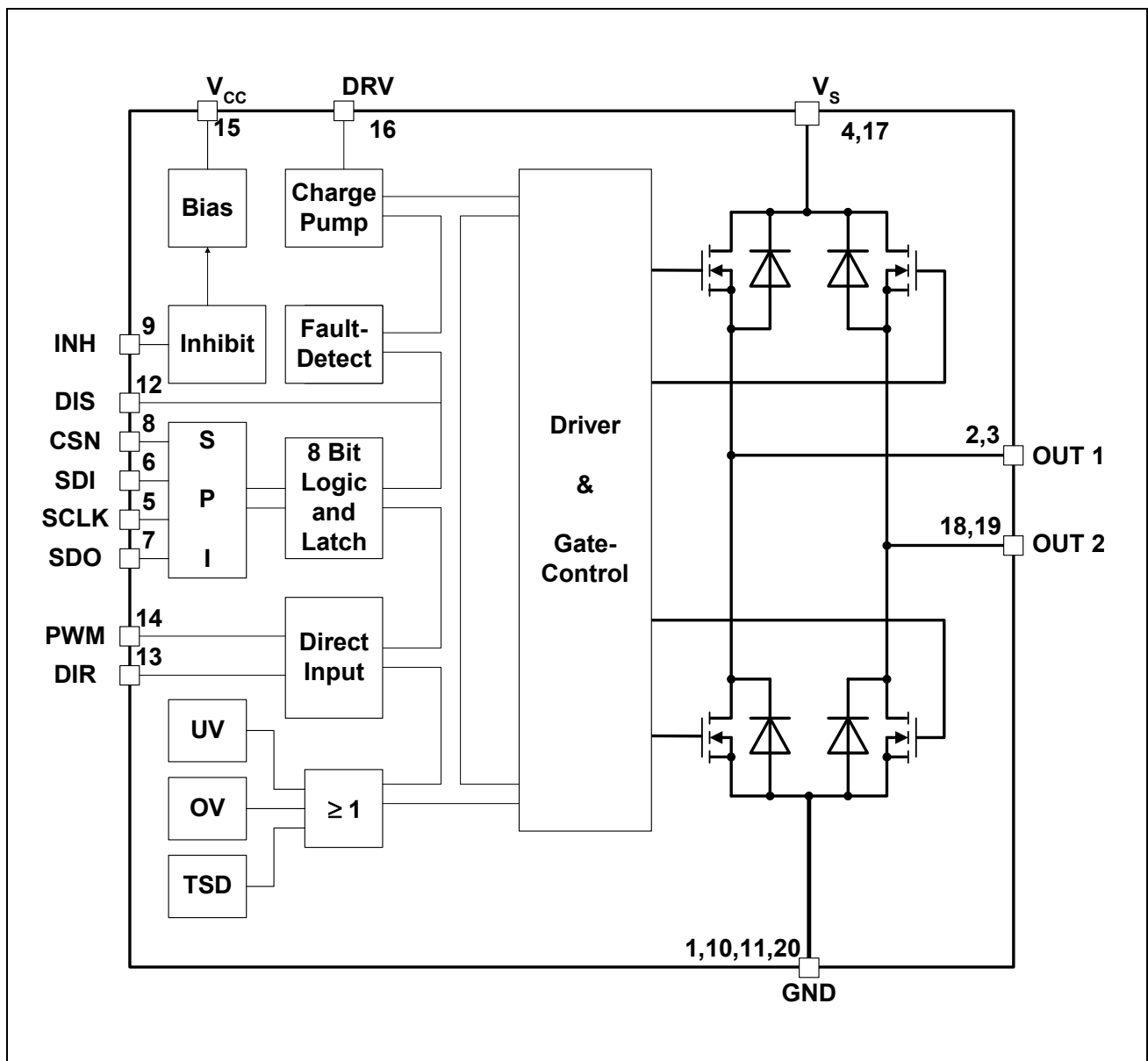

Figure 1 Block Diagram

## 2 Circuit Description

### 2.1 Serial Peripheral Interface (SPI)

The SPI is used for bidirectional communication with a control unit. The 8-bit programming word or control word (see **Table 1**) is read in via the SDI serial data input, and this is synchronized with the serial clock input SCLK. The status word appears synchronously at the SDO serial data output (see **Table 4**).

The transmission cycle begins when the chip is selected with the chip-select-not (CSN) input (H to L). When the CSN input changes from L to H, the word which has been read into the shift register becomes the control word. The SDO output switches then to tristate status, thereby releasing the SDO bus circuit for other uses. The SPI allows to parallel multiple SPI devices by using multiple CSN lines. Due to the full duplex shift register, the TLE 6209 R can also be used in daisy-chain configuration.

The settings made by the SPI control word become active at the end of the SPI transmission and remain valid until a different control word is transmitted or a power on reset occurs. At each SPI transmission, the diagnosis bits as currently valid in the error logic are transmitted. The behavior of the diagnosis bits is described in **Section 2.5**.

**Table 1 Input Data Protocol**

Bit	
7	Status Register Reset: H = reset
6	OVLO: H = on, L = off
5	not used
4	MSB of 2bit chopper-OFF-time
3	LSB of 2bit chopper-OFF-time
2	PWM Operation mode: H = Fast decay, L = Slow decay
1	MSB of 2 bit chopper current limit
0	LSB of 2 bit chopper current limit

**Table 2 Programmable Chopper Current Limit  $I_{L\_xx}$** 

Bit 1	Bit 0	Current limit
0	0	$I_{L\_00}$
0	1	$I_{L\_01}$
1	0	$I_{L\_10}$
1	1	$I_{L\_11}$

*Note: For actual values, see page 16*

**Table 3 Programmable Chopper OFF-time  $t_{OFF\_xx}$** 

Bit 4	Bit 3	Chopper-OFF-time
0	0	$t_{OFF\_00}$
0	1	$t_{OFF\_01}$
1	0	$t_{OFF\_10}$
1	1	$t_{OFF\_11}$

*Note: For actual values, see page 16*

**Table 4 Diagnosis Data Protocol**

Bit	H = Error/L = no error
7	Power supply fail
6	not used, always H
5	Short to $V_S$ or across the load
4	Short to GND
3	Open load
2	MSB of Temperature Monitoring
1	LSB of Temperature Monitoring
0	Error-Flag

**Table 5 Temperature Monitoring**

Bit 2	Bit 1	Chip Temperature
0	0	Below Prewarning
0	1	Temperature Prewarning

**Table 5 Temperature Monitoring**

Bit 2	Bit 1	Chip Temperature
1	0	Temperature Warning
1	1	Overtemperature Shutdown

## 2.2 Supply

### 2.2.1 Logic Supply Voltage, Power-On-Reset

The logic is supplied with 5 V by the  $V_{CC}$  pin, separated from the power stage supply  $V_S$ . The advantage of this system is that information stored in the logic remains intact even in the event of failures in the supply voltage  $V_S$ . The power supply failure information can be read out via the SPI. If  $V_{CC}$  falls below typically 4.5 V, the logic is shut down, all internally stored data is deleted and the Output Stages are switched to tristate. The IC is restarted on rising  $V_{CC}$  with a hysteresis of typically 80 mV

After this restart at increasing  $V_{CC}$ , or if the device is activated after having been set into inhibit mode (INH L to H), the IC is initialized by Power-On-Reset (POR). After POR, all SPI control bits are set to L. This setting remains valid until first SPI communication. Also the error bits are reset by POR.

### 2.2.2 Power Supply Voltage

The power stages are connected to the supply voltage  $V_S$ . This voltage is monitored by over voltage (OV) and under voltage (UV) comparators as described in **Section 2.5.6**. The power supply voltage needs a blocking capacitor to GND.

## 2.3 Direct Inputs

### 2.3.1 Inhibit (sleep mode)

The INH input can be used to cut off the complete IC. By pulling the INH input to low, the power stages are switched to tristate, and the current consumption is reduced to just a few  $\mu\text{A}$  at both the  $V_S$  and the  $V_{CC}$  input. It also leads to the loss of any data stored. The TLE 6209 R is reinitialized with POR if INH is put to high again. The pin has an internal pull-down.

### 2.3.2 Disable

The DIS input can be used to disable the output stages. By pulling the DIS input to high the power stages are switched to tristate, regardless of the signals at the DIR and PWM inputs. The DIS input can be used as an emergency disable without resetting the SPI data stored in the IC. It has an internal pull-up.

### 2.3.3 Direction and PWM

The power stages are controlled by the direct inputs DIR and PWM as given in **Table 6** and further illustrated in **Figure 2**. The DIR input gives the direction of output current, while the PWM input controls whether the current is increased or reduced. The SPI control bit 2 sets the decay mode, i.e. determines what happens if PWM = L. In pulse-width modulated applications, this control scheme allows to supply the PWM-signal always through the same port, using less controller resources.

**Table 6 Functional Truth Table**

DIR	PWM	MODE (Bit 2)	OUT1	OUT2	Comments
0	1	0 (slow decay)	H	L	Motor turns clockwise
0	0		H	H	Freewheel with slow decay
1	1		L	H	Motor turns counterclockwise
1	0		H	H	Freewheel with slow decay
0	1	1 (fast decay)	H	L	Motor turns clockwise
0	0		L	H	Fast decay
1	1		L	H	Motor turns counterclockwise
1	0		H	L	Fast decay

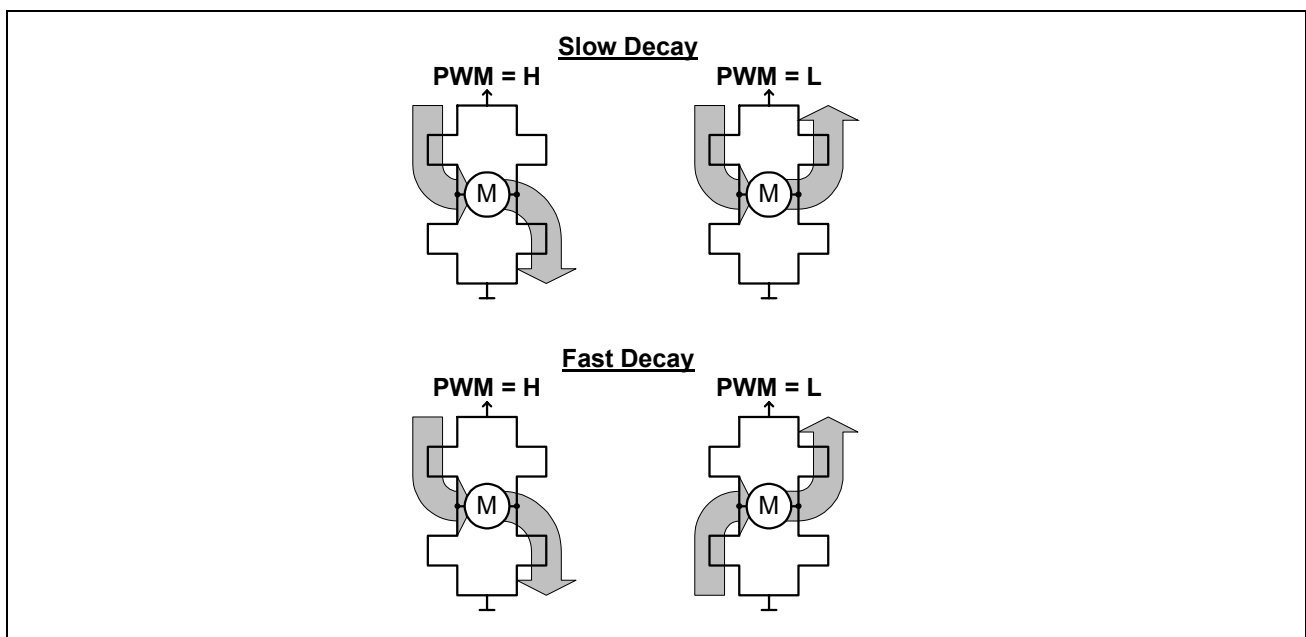

**Figure 2 DIR/PWM Control with Slow- and Fast Decay**



## 2.4 Power Stages

The output stages consist of a DMOS H-bridge built by two highside switches and two lowside switches. Integrated circuits protect the outputs against overcurrent and overtemperature if there is a short-circuit to ground or to the supply voltage or across the load. Positive and negative voltage spikes, which occur when switching inductive loads, are limited by integrated freewheeling diodes.

### 2.4.1 Charge Pump

To realize the fast switching times, the charge pump, which generates the voltage necessary to switch on the n-channel D-MOS high-side switches, must be highly efficient. It requires an external capacitor  $C_{DRV}$  which is connected to  $V_S$  and the charge pump buffer input, DRV. It should be placed as close to the pins as possible.

### 2.4.2 Chopper Current Limitation

To limit the output current, a chopper current limitation is integrated as shown in **Figure 3**. The current is measured by sense cells integrated in the low-side switches. As soon the current limit  $I_L$  is reached, the low-side switch is switched off for a fixed time  $t_{OFF}$ .  $I_L$  and  $t_{OFF}$  can be set by the SPI control bits 0,1, 3 and 4.

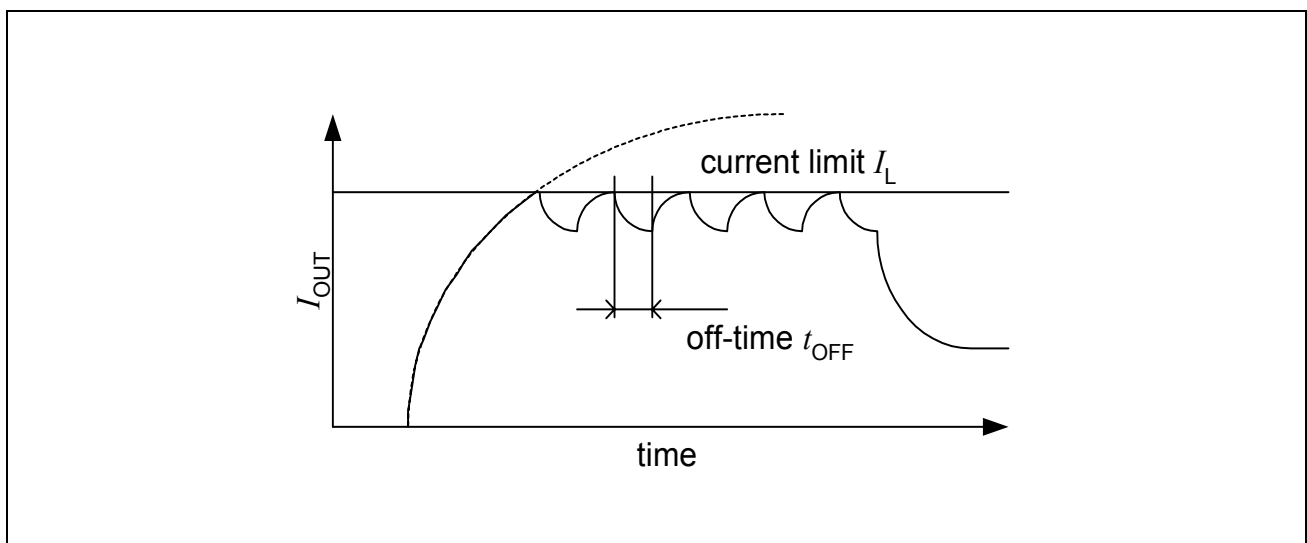

**Figure 3** Chopper current limitation

### 2.4.3 Active Freewheeling

When driving inductive loads with PWM operation, the dissipated power can be significantly reduced by activating the transistor located parallel to the internal freewheeling diode. This is realized in the TLE 6209 R. When switching an output from L to H, the high-side switch is turned on after a certain dead-time to avoid cross currents flowing through the half bridge.

## 2.5 Protection and Diagnosis

### 2.5.1 Short of Output to Ground

The high-side switches are protected against a short of the output to ground by an over current shutdown. If a high-side switch is turned on and the current rises above the high-side shutdown threshold  $I_{SDH}$  for longer than the shutdown delay time  $t_{dOC}$ , all output transistors are turned off and bit 4 the SPI diagnosis word is set. During the delay time, the current is limited to  $I_{SC}$  (typically 20 A). The output stages stay off and the error bit set until a status register reset (bit 7 of SPI control word) is received or a power-on reset is performed.

### 2.5.2 Short of Output to $V_S$

Due to the chopper current regulation, the low-side switches are protected against a short to the supply voltage. To detect the short, the first time the current limit is reached, the off-command for the low-side switch is blanked out for 10  $\mu$ s. If the current rises above the low-side shutdown threshold  $I_{SDL}$  during this time, all output transistors are turned off and bit 5 in the SPI diagnosis word is set. The value of the shutdown threshold depends on the current limit that is set via the SPI. The shutdown threshold is 1 A higher than the current limit. The output stages stay off and the error bit set until a status register reset (bit 7 of SPI control word) is received or a power-on reset is performed.

### 2.5.3 Short Across the Load

The short circuit protection circuits of the high- and low-side switches work independently of each other. In most cases, a short across the load will be detected as a short to  $V_S$  because of the longer filter time in the high-side switches  $t_{dOC}$  and the higher shutdown threshold  $I_{SDH}$ .

### 2.5.4 Open Load

If the current through the low side transistor is lower than the reference current  $I_{dOL}$  in ON-state (PWM = H), a timer is started. After a filter time  $t_{dOC}$  an open load failure will be recognized and the status bit 3 is set. If the current exceeds the reference current  $I_{dOL}$  the open load timer is reset. If the H-bridge is switched to OFF-state (PWM = L) the timer is stopped but not reset. The timer continues if the H-bridge is switched to ON-state again. There is no reset of the open load timer if the direction is changed using the DIR input in open load condition. The open load error bit is latched and can be reset by the status register reset bit 7 of the SPI control word or a POR.

### 2.5.5 Temperature Monitoring

Temperature sensors are integrated in the power stages. The temperature monitoring circuit compares the measured temperature to the prewarning, warning and shutdown

thresholds. As soon as a threshold is reached, the according status bits are set in the SPI diagnosis word (c.f. **Table 5**). If the overtemperature shutdown threshold is reached, the output stages are turned off. The temperature monitoring messages and the over temperature shutdown are latched and can be reset by the status register reset bit 7 of the SPI control word or a POR.

### 2.5.6 Power Supply Fail

The power supply Voltage is monitored for over- and under voltage lockout:

- **Under Voltage Lockout**

If the supply voltage  $V_S$  drops below the switch off voltage  $V_{UV\ OFF}$ , all output transistors are switched off and the power supply fail bit (bit 7 of the SPI diagnosis word) is set. If  $V_S$  rises again and reaches the switch on voltage  $V_{UV\ ON}$ , the power stages are restarted. The error bit, however, is latched and has to be reset by the status register reset bit 7 of the SPI control word.

- **Over Voltage Lockout**

If the supply voltage  $V_S$  rises above the switch off voltage  $V_{OV\ OFF}$ , all output transistors are switched off and the power supply fail bit (bit 7 of the SPI diagnosis word) is set. If  $V_S$  falls again and reaches the switch on voltage  $V_{OV\ ON}$ , the power stages are restarted. The error bit, however, is latched and has to be reset by the status register reset bit 7 of the SPI control word.

The OVLO is only active if control bit 6 is H. If the bit is low, the OVLO is deactivated.

### 2.5.7 Error Flag

Bit 0 of the SPI diagnosis word is an OR of the status bits 1 to 7. It can be read out without full SPI communication as described in **Figure 8**.

### 3 Characteristics

#### 3.1 Absolute Maximum Ratings

Parameter	Symbol	Limit Values		Unit	Remarks
		min.	max.		

#### Voltages

Supply voltage	$V_S$	- 0.3	40	V	-
Supply voltage	$V_S$	- 1	45	V	$t < 0.5 \text{ s}; I_S > - 2 \text{ A}$
Logic supply voltage	$V_{CC}$	- 0.3	5.5	V	$0 \text{ V} < V_S < 40 \text{ V}$
Logic input voltages (SDI, SCLK, CSN, INH, DIS, PWM, DIR)	$V_I$	- 0.3	5.5	V	$0 \text{ V} < V_S < 40 \text{ V}$ $0 \text{ V} < V_{CC} < 5.5 \text{ V}$
Logic output voltage (SDO)	$V_O$	- 0.3	5.5	V	$0 \text{ V} < V_S < 40 \text{ V}$ $0 \text{ V} < V_{CC} < 5.5 \text{ V}$
Output voltage (OUT1, OUT2)	$V_{OUT}$	- 0.3 V	$V_S + 1.5 \text{ V}$	-	$0 \text{ V} < V_S < 40 \text{ V}$
Charge pump buffer voltage (DRV)	$V_{DRV}$	$V_S - 0.3 \text{ V}$	$V_S + 15 \text{ V}$	-	$0 \text{ V} < V_S < 40 \text{ V}$

#### Currents

Output current (cont.)	$I_{OUT}$	-	-	A	internally limited, see page 16 and page 17.
Output current (peak)	$I_{OUT}$	-	-	A	

#### Temperatures

Junction temperature	$T_j$	- 40	150	°C	-
Storage temperature	$T_{stg}$	- 50	150	°C	-

*Note: Maximum ratings are absolute ratings; exceeding any one of these values may cause irreversible damage to the integrated circuit.*

### 3.2 Operating Range

Parameter	Symbol	Limit Values		Unit	Remarks
		min.	max.		
Supply voltage	$V_S$	$V_{UV\ OFF}$	40	V	After $V_S$ rising above $V_{UV\ ON}$
Supply voltage slew rate	$dV_S/dt$	-10	10	V/ $\mu$ s	-
Logic supply voltage	$V_{CC}$	4.75	5.50	V	-
Supply voltage increasing	$V_S$	- 0.3	$V_{UV\ ON}$	V	Outputs in tristate
Supply voltage decreasing	$V_S$	- 0.3	$V_{UV\ OFF}$	V	Outputs in tristate
Logic input voltage (SDI, SCLK, CSN, INH)	$V_I$	- 0.3	$V_{CC}$	V	-
SPI clock frequency	$f_{CLK}$	-	2	MHz	-
Junction temperature	$T_j$	- 40	150	$^{\circ}$ C	-

### Thermal Resistances

Junction pin	$R_{thjC}$	-	1.5	K/W	measured to pin 1, 10, 11, 20
Junction ambient	$R_{thjA}$	-	50	K/W	-

### 3.3 Electrical Characteristics

8 V <  $V_S$  < 40 V; 4.75 V <  $V_{CC}$  < 5.25 V; INH = High; all outputs open;  
 – 40 °C <  $T_j$  < 150 °C; unless otherwise specified

Parameter	Symbol	Limit Values			Unit	Test Conditions
		min.	typ.	max.		

#### Current Consumption

Quiescent current	$I_S$	–	–	50	μA	INH = Low; $V_S = 13.2$ V
Quiescent current	$I_S$	–	10	30	μA	INH = Low; $V_S = 13.2$ V; $T_j = 25$ °C
Logic-Supply current	$I_{CC}$	–	–	20	μA	INH = Low
Logic-Supply current	$I_{CC}$	–	2.0	4.0	mA	–
Supply current	$I_S$	–	2.8	5.0	mA	–

#### Over- and Under-Voltage Lockout

UV-Switch-ON voltage	$V_{UV\ ON}$	–	5.4	5.7	V	$V_S$ increasing
UV-Switch-OFF voltage	$V_{UV\ OFF}$	4.4	4.9	5.2	V	$V_S$ decreasing
UV-ON/OFF-Hysteresis	$V_{UV\ HY}$	0.2	0.5	–	V	$V_{UV\ ON} - V_{UV\ OFF}$
OV-Switch-OFF voltage	$V_{OV\ OFF}$	34	37	40	V	$V_S$ increasing
OV-Switch-ON voltage	$V_{OV\ ON}$	28	32	36	V	$V_S$ decreasing
OV-ON/OFF-Hysteresis	$V_{OV\ HY}$	–	5.0	–	V	$V_{OV\ OFF} - V_{OV\ ON}$

### 3.3 Electrical Characteristics (cont'd)

8 V <  $V_S$  < 40 V; 4.75 V <  $V_{CC}$  < 5.25 V; INH = High; all outputs open;  
 – 40 °C <  $T_j$  < 150 °C; unless otherwise specified

Parameter	Symbol	Limit Values			Unit	Test Conditions
		min.	typ.	max.		

#### Outputs OUT1-2

##### Static Drain-Source-On Resistance

Source (High-Side) $I_{OUT} = -3\text{ A}$	$R_{DS\ ON\ H}$	–	140	170	mΩ	5.2 V < $V_S$ < 40 V $T_j = 25\text{ °C}$ ; $C_{DRV} = 33\text{ nF}$
			–	280	mΩ	5.2 V < $V_S$ < 40 V $C_{DRV} = 33\text{ nF}$
Sink (Low-Side) $I_{OUT} = 3\text{ A}$	$R_{DS\ ON\ L}$	–	130	160	mΩ	5.2 V < $V_S$ < 40 V $T_j = 25\text{ °C}$ ; $C_{DRV} = 33\text{ nF}$
			–	270	mΩ	5.2 V < $V_S$ < 40 V $C_{DRV} = 33\text{ nF}$

##### Clamp Diodes Forward Voltage

Upper	$V_{FU}$	–	1.0	1.5	V	$I_F = 3\text{ A}$
Lower	$V_{FL}$	–	1.0	1.5	V	$I_F = 3\text{ A}$

### 3.3 Electrical Characteristics (cont'd)

8 V <  $V_S$  < 40 V; 4.75 V <  $V_{CC}$  < 5.25 V; INH = High; all outputs open;  
 – 40 °C <  $T_j$  < 150 °C; unless otherwise specified

Parameter	Symbol	Limit Values			Unit	Test Conditions
		min.	typ.	max.		

#### Open Circuit/Underload Detection

Detection current	$I_{OCD}$	30	–	130	mA	–
Delay time	$t_{dOC}$	2	–	8	ms	–

#### Current Limits

Current limit	$I_{L\_00}$	3.4	4	4.6	A	Bit 0 = L; Bit 1 = L;
Current limit	$I_{L\_01}$	4.25	5	5.75	A	Bit 0 = H; Bit 1 = L;
Current limit	$I_{L\_10}$	5.1	6	6.9	A	Bit 0 = L; Bit 1 = H;
Current limit	$I_{L\_11}$	5.95	7	8.05	A	Bit 0 = H; Bit 1 = H;

#### Low-Side Switch Overcurrent

Shutdown Threshold	$\Delta I_{SDL}$	0.5	1.0	1.5	A	$\Delta I_{SDL} = I_{SDL} - I_L$
--------------------	------------------	-----	-----	-----	---	----------------------------------

*Note: low-side shutdown threshold is guaranteed by design*

#### Switch-OFF Time during Current Limitation (Chopper OFF-Time)

OFF-time	$t_{OFF\_00}$	16	24	28	μs	Bit 3 = L; Bit 4 = L;
OFF-time	$t_{OFF\_01}$	32	43	51	μs	Bit 3 = H; Bit 4 = L;
OFF-time	$t_{OFF\_10}$	48	62	74	μs	Bit 3 = L; Bit 4 = H;
OFF-time	$t_{OFF\_11}$	64	80	96	μs	Bit 3 = H; Bit 4 = H;



### 3.3 Electrical Characteristics (cont'd)

8 V <  $V_S$  < 40 V; 4.75 V <  $V_{CC}$  < 5.25 V; INH = High; all outputs open;  
 – 40 °C <  $T_j$  < 150 °C; unless otherwise specified

Parameter	Symbol	Limit Values			Unit	Test Conditions
		min.	typ.	max.		

#### High-Side Switch Overcurrent

High-side shutdown threshold	$I_{SDH}$	8	12	18	A	–
Shutdown delay time	$t_{dSD}$	15	25	40	µs	–
Short circuit current	$I_{SC}$	–	–	25	A	during $t_{dSD}$

*Note: For short circuit current definition, see **Figure 5**. Short circuit current is guaranteed by design*

#### Leakage Current / Output Current in Tristate

Source-Output-Stage	$I_{QLH}$	– 120	– 50	–	µA	$V_{OUT} = 0\text{ V}$
Sink-Output-Stage	$I_{QLL}$	–	0.5	1	mA	$V_{OUT} = V_S$

#### Output Delay Times (device not in stand-by for $t > 1\text{ ms}$ )

High-side ON	$t_{d\text{ ON H}}$	–	4	10	µs	$V_S = 13.2\text{ V}$ , Resistive load of 12 Ω
High-side OFF	$t_{d\text{ OFF H}}$	–	0.6	1	µs	
Low-side ON	$t_{d\text{ ON L}}$	–	2	3.5	µs	
Low-side OFF	$t_{d\text{ OFF L}}$	–	2.5	4	µs	

#### Output Switching Times (device not in stand-by for $t > 1\text{ ms}$ )

High-side switch rise time	$t_{\text{RISE H}}$	–	1.8	3.5	µs	$V_S = 13.2\text{ V}$ , Resistive load of 12 Ω
High-side switch fall time	$t_{\text{FALL H}}$	–	0.2	0.8	µs	
Low-side switch rise time	$t_{\text{RISE L}}$	2	6.5	11	µs	
Low-side switch fall time	$t_{\text{FALL L}}$	2	4.3	6.5	µs	

*Note: For switching time definitions, see **Figure 6**.*

### 3.3 Electrical Characteristics (cont'd)

8 V <  $V_S$  < 40 V; 4.75 V <  $V_{CC}$  < 5.25 V; INH = High; all outputs open;  
 – 40 °C <  $T_j$  < 150 °C; unless otherwise specified

Parameter	Symbol	Limit Values			Unit	Test Conditions
		min.	typ.	max.		

#### Inhibit Input

H-input voltage threshold	$V_{IINH}$	–	–	0.7	$V_{CC}$	–
L-input voltage threshold	$V_{IINHL}$	0.2	–	–	$V_{CC}$	–
Hysteresis of input voltage	$V_{IINHYY}$	50	300	500	mV	–
Pull down current (low)	$I_{IINHL}$	10	25	50	$\mu$ A	$V_{IINH} = 0.2 \times V_{CC}$
Pull down current (high)	$I_{IINH}$	–	–	80	$\mu$ A	$V_{IINH} = 0.7 \times V_{CC}$

#### Disable Input

H-input voltage threshold	$V_{IDISH}$	–	–	0.7	$V_{CC}$	–
L-input voltage threshold	$V_{IDISL}$	0.2	–	–	$V_{CC}$	–
Hysteresis of input voltage	$V_{IDISHY}$	50	300	500	mV	–
Pull up current (high)	$I_{IDISH}$	– 50	– 25	– 10	$\mu$ A	$V_{IDIS} = 0.7 \times V_{CC}$
Pull up current (low)	$I_{IDISL}$	– 50	–	–	$\mu$ A	$V_{IDIS} = 0.2 \times V_{CC}$

#### Direction/PWM Input

H-input voltage threshold	$V_{IH}$	–	–	0.7	$V_{CC}$	–
L-input voltage threshold	$V_{IL}$	0.2	–	–	$V_{CC}$	–
Hysteresis of input voltage	$V_{IHYY}$	50	300	500	mV	–
Pull down current (low)	$I_I$	10	25	50	$\mu$ A	$V_I = 0.2 \times V_{CC}$
Pull down current (high)	$I_I$	–	–	50	$\mu$ A	$V_I = 0.7 \times V_{CC}$

### 3.3 Electrical Characteristics (cont'd)

8 V <  $V_S$  < 40 V; 4.75 V <  $V_{CC}$  < 5.25 V; INH = High; all outputs open;  
 – 40 °C <  $T_j$  < 150 °C; unless otherwise specified

Parameter	Symbol	Limit Values			Unit	Test Conditions
		min.	typ.	max.		

#### SPI-Interface

##### Delay Time from Stand-by to Data In/Power on Reset

Setup time	$t_{set}$	–	–	100	μs	–
------------	-----------	---	---	-----	----	---

##### Logic Inputs SDI, SCLK and CSN

H-input voltage threshold	$V_{IH}$	–	–	0.7	$V_{CC}$	–
L-input voltage threshold	$V_{IL}$	0.2	–	–	$V_{CC}$	–
Hysteresis of input voltage	$V_{IH\text{Y}}$	50	300	500	mV	–
Pull up current at pin CSN (high)	$I_{ICSNH}$	– 50	– 25	– 10	μA	$V_{CSN} = 0.7 \times V_{CC}$
Pull up current at pin CSN (low)	$I_{ICSNL}$	– 50	–	–	μA	$V_{CSN} = 0.2 \times V_{CC}$
Pull down current at pin SDI and SCLK (low)	$I_{ISDIL}$ ( $I_{ISCLKL}$ )	10	25	50	μA	$V_{SDI} (V_{SCLK}) = 0.2 \times V_{CC}$
Pull down current at pin SDI and SCLK (high)	$I_{ISDIH}$ ( $I_{ISCLKH}$ )	–	–	50	μA	$V_{SDI} (V_{SCLK}) = 0.7 \times V_{CC}$
Input capacitance at pin CSN, SDI or SCLK	$C_1$	–	10	15	pF	0 V < $V_{CC}$ < 5.25 V

*Note: Input capacitances are guaranteed by design.*

**3.3 Electrical Characteristics (cont'd)**

8 V <  $V_S$  < 40 V; 4.75 V <  $V_{CC}$  < 5.25 V; INH = High; all outputs open;  
 – 40 °C <  $T_j$  < 150 °C; unless otherwise specified

Parameter	Symbol	Limit Values			Unit	Test Conditions
		min.	typ.	max.		

**Logic Output SDO**

H-output voltage level	$V_{SDOH}$	$V_{CC}$ –1.0	$V_{CC}$ –0.85	–	V	$I_{SDOH} = 1 \text{ mA}$
L-output voltage level	$V_{SDOL}$	–	0.25	0.4	V	$I_{SDOL} = -1.6 \text{ mA}$
Tri-state leakage current	$I_{SDOLK}$	– 10	–	10	μA	$V_{CSN} = V_{CC}$ $0 \text{ V} < V_{SDO} < V_{CC}$
Tri-state input capacitance	$C_{SDO}$	–	10	15	pF	$V_{CSN} = V_{CC}$ $0 \text{ V} < V_{CC} < 5.25 \text{ V}$

*Note: Input capacitances are guaranteed by design.*

### 3.3 Electrical Characteristics (cont'd)

8 V <  $V_S$  < 40 V; 4.75 V <  $V_{CC}$  < 5.25 V; INH = High; all outputs open;  
 – 40 °C <  $T_j$  < 150 °C; unless otherwise specified

Parameter	Symbol	Limit Values			Unit	Test Conditions
		min.	typ.	max.		

#### Serial Data Input Timing

Serial Clock period	$t_{PCLK}$	500	–	–	ns	–
Serial Clock high time	$t_{SCLKH}$	250	–	–	ns	–
Serial Clock low time	$t_{SCLKL}$	250	–	–	ns	–
Serial Clock low before CSN low	$t_{bef}$	250	–	–	ns	–
CSN setup time	$t_{lead}$	250	–	–	ns	–
SCLK setup time	$t_{lag}$	250	–	–	ns	–
Clock low after CSN high	$t_{beh}$	250	–	–	ns	–
SDI setup time	$t_{SDISU}$	125	–	–	ns	–
SDI hold time	$t_{SDIHO}$	125	–	–	ns	–
Input signal rise time at pin SDI, SCLK and CSN	$t_{rSIN}$	–	–	100	ns	–
Input signal fall time at pin SDI, SCLK and CSN	$t_{fSIN}$	–	–	100	ns	–

#### Serial Data Output Timing

SDO rise time	$t_{rSDO}$	–	25	50	ns	$C_L = 100$ pF
SDO fall time	$t_{fSDO}$	–	25	50	ns	$C_L = 100$ pF
SDO enable time	$t_{ENSDO}$	–	–	125	ns	low impedance
SDO disable time	$t_{DISSDO}$	–	–	125	ns	high impedance
SDO valid time	$t_{VASDO}$	–	50	125	ns	$V_{DO} < 0.2 V_{CC}$ ; $V_{DO} > 0.7 V_{CC}$ ; $C_L = 100$ pF

### 3.3 Electrical Characteristics (cont'd)

8 V <  $V_S$  < 40 V; 4.75 V <  $V_{CC}$  < 5.25 V; INH = High; all outputs open;  
 – 40 °C <  $T_j$  < 150 °C; unless otherwise specified

Parameter	Symbol	Limit Values			Unit	Test Conditions
		min.	typ.	max.		

#### Thermal Prewarning, Warning and Shutdown

Thermal prewarning junction temperature	$T_{jPW}$	120	140	160	°C	–
Temperature prewarning hysteresis	$\Delta T$	–	20	–	K	–
Thermal warning junction temperature	$T_{jW}$	140	160	180	°C	–
Temperature prewarning hysteresis	$\Delta T$	–	20	–	K	–
Thermal shutdown junction temperature	$T_{jSD}$	160	180	200	°C	–
Temperature shutdown hysteresis	$\Delta T$	–	20	–	K	–
Ratio of W to PW temperature	$T_{jW} / T_{jPW}$	1.07	1.14	–	–	–
Ratio of SD to W temperature	$T_{jSD} / T_{jW}$	1.06	1.13	–	–	–

*Note: Temperature thresholds are guaranteed by design.*

4 Diagrams

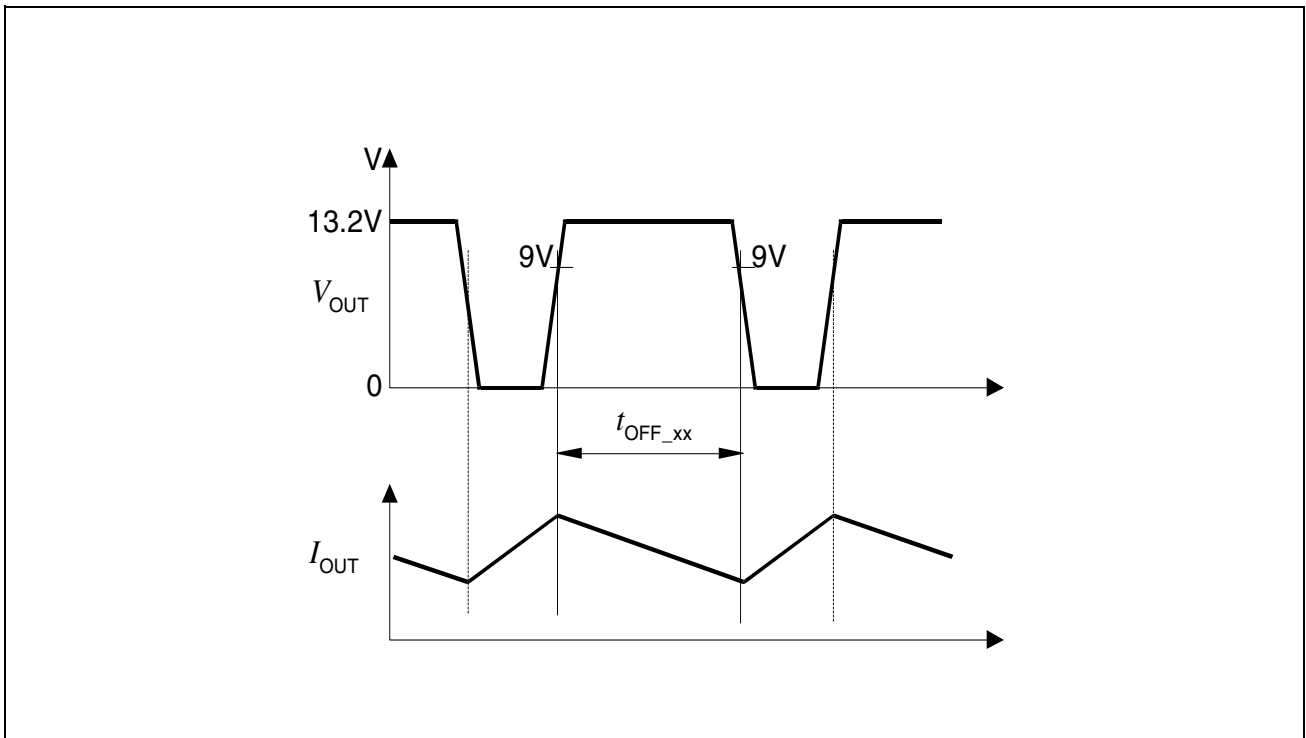

Figure 4 Switch-OFF time during current limitation (chopper OFF-time)

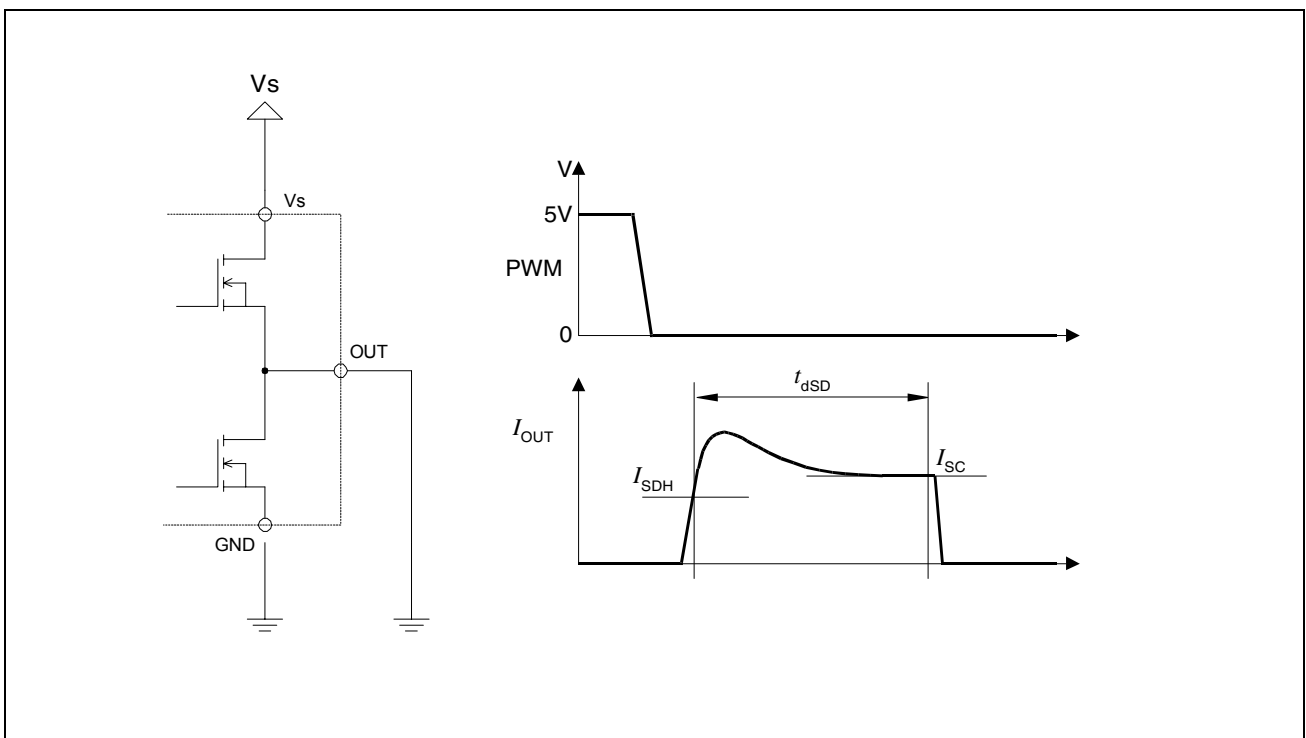
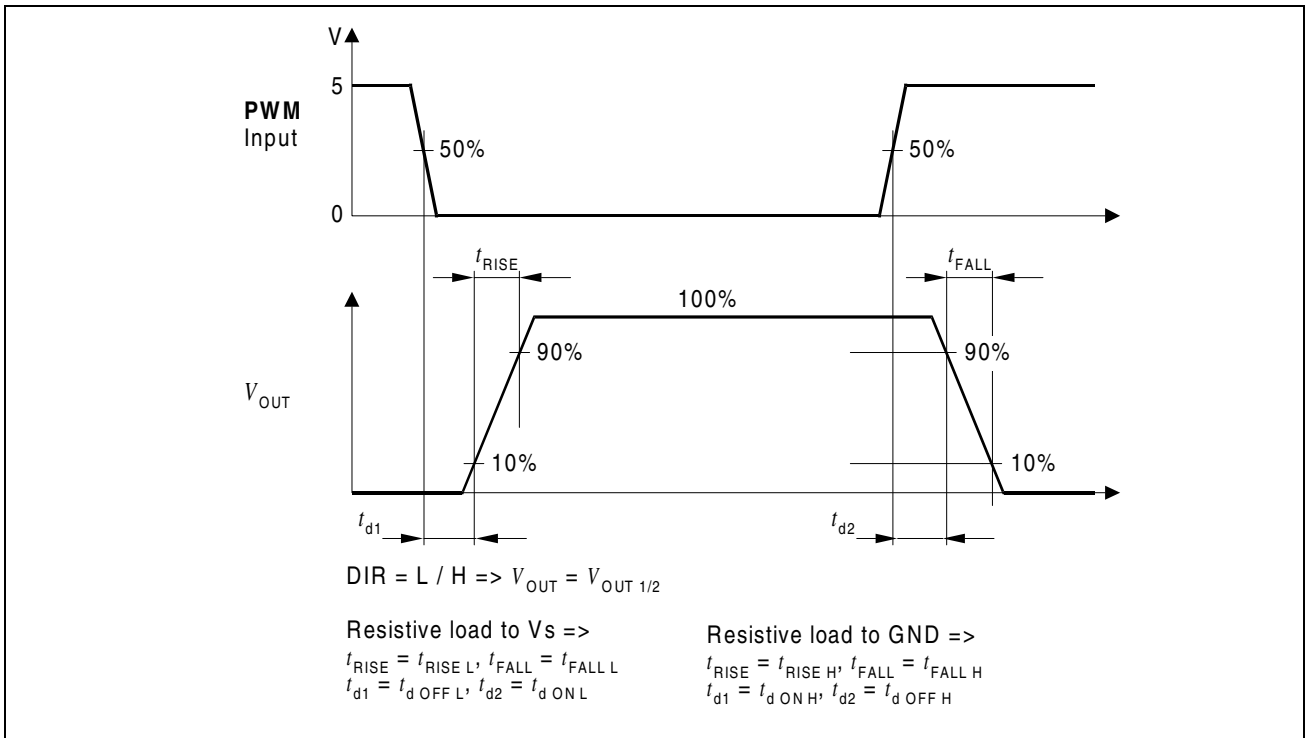
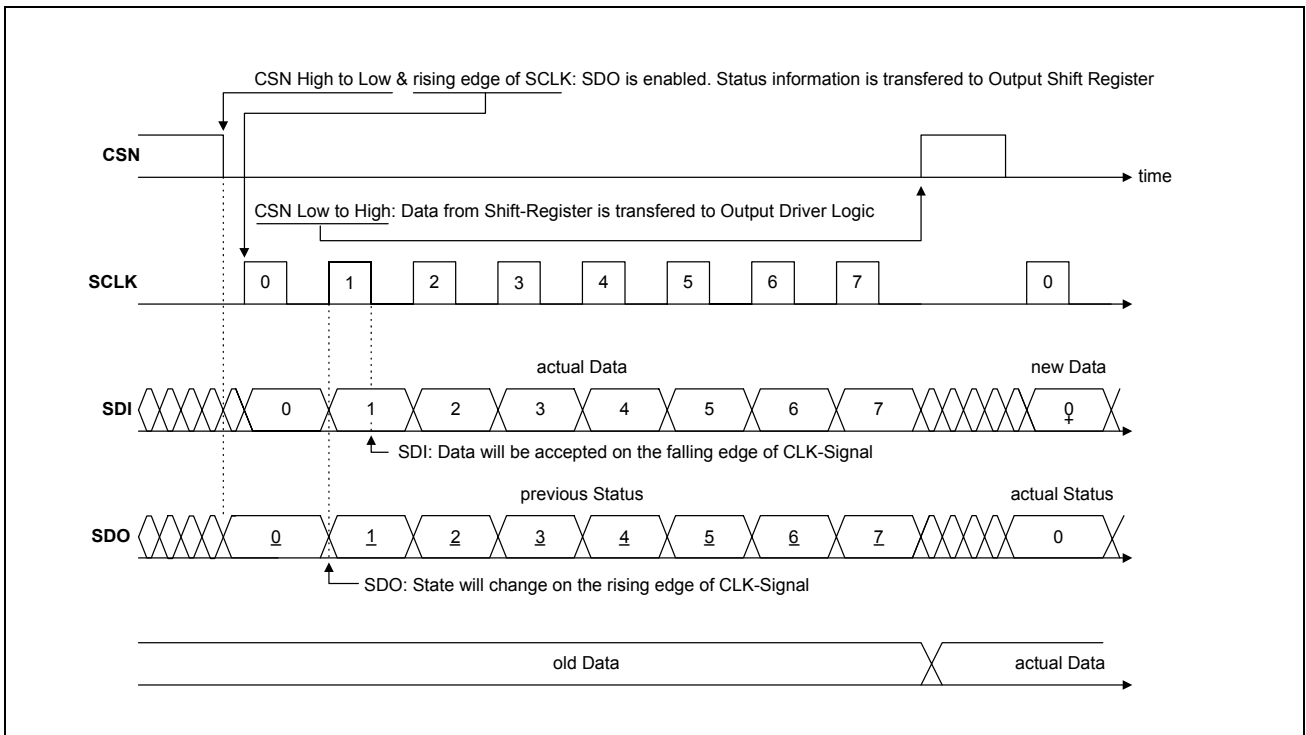

Figure 5 Short circuit of high-side switch to GND

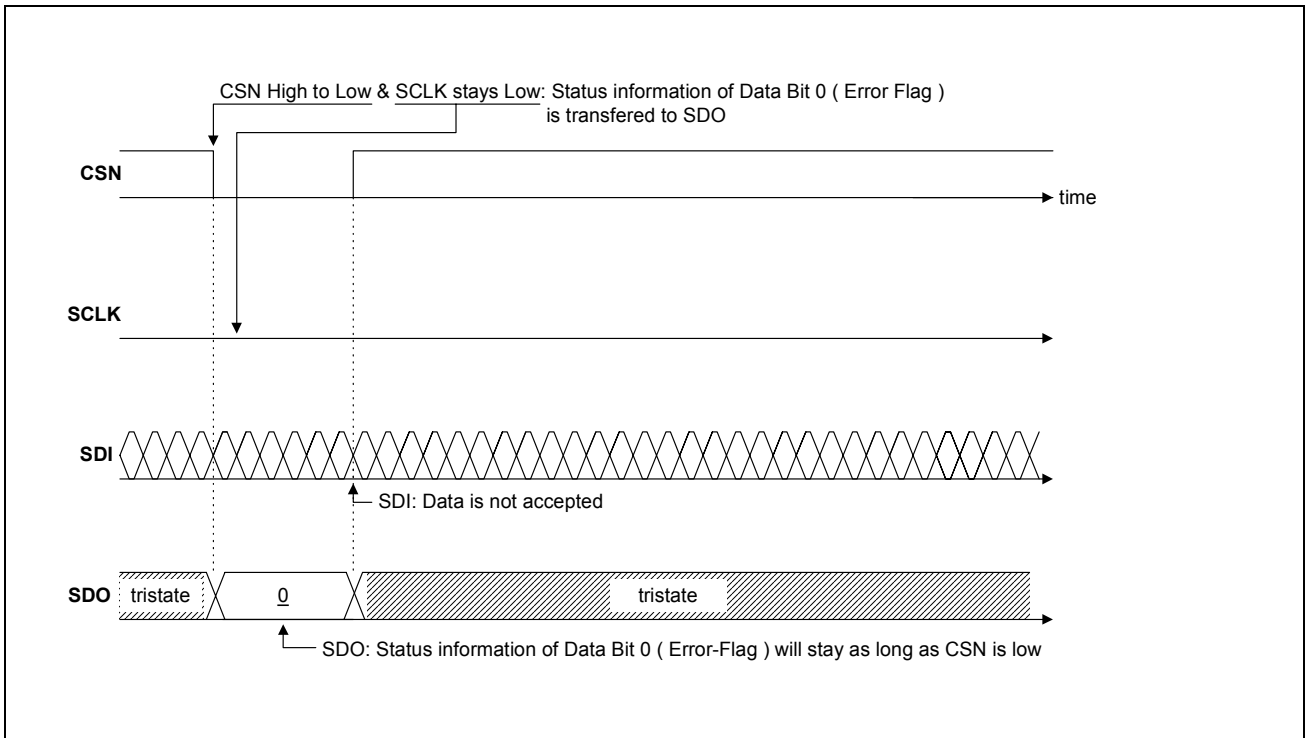

**Figure 6 Output Delay and Switching Time Definitions**

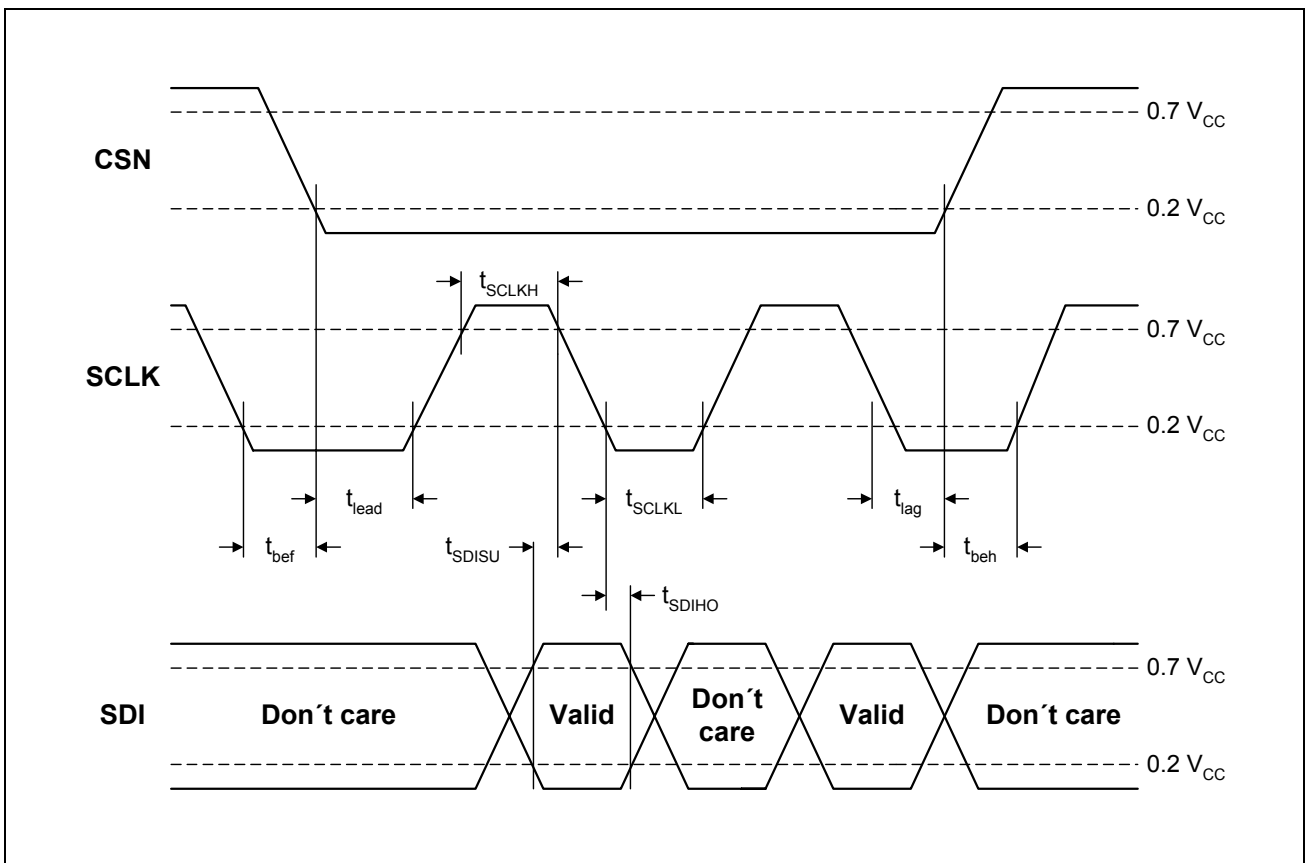

**Figure 7 Standard Data Transfer Timing**





**Figure 8 Timing for Error Detection Only**



**Figure 9 SPI-Input Timing**

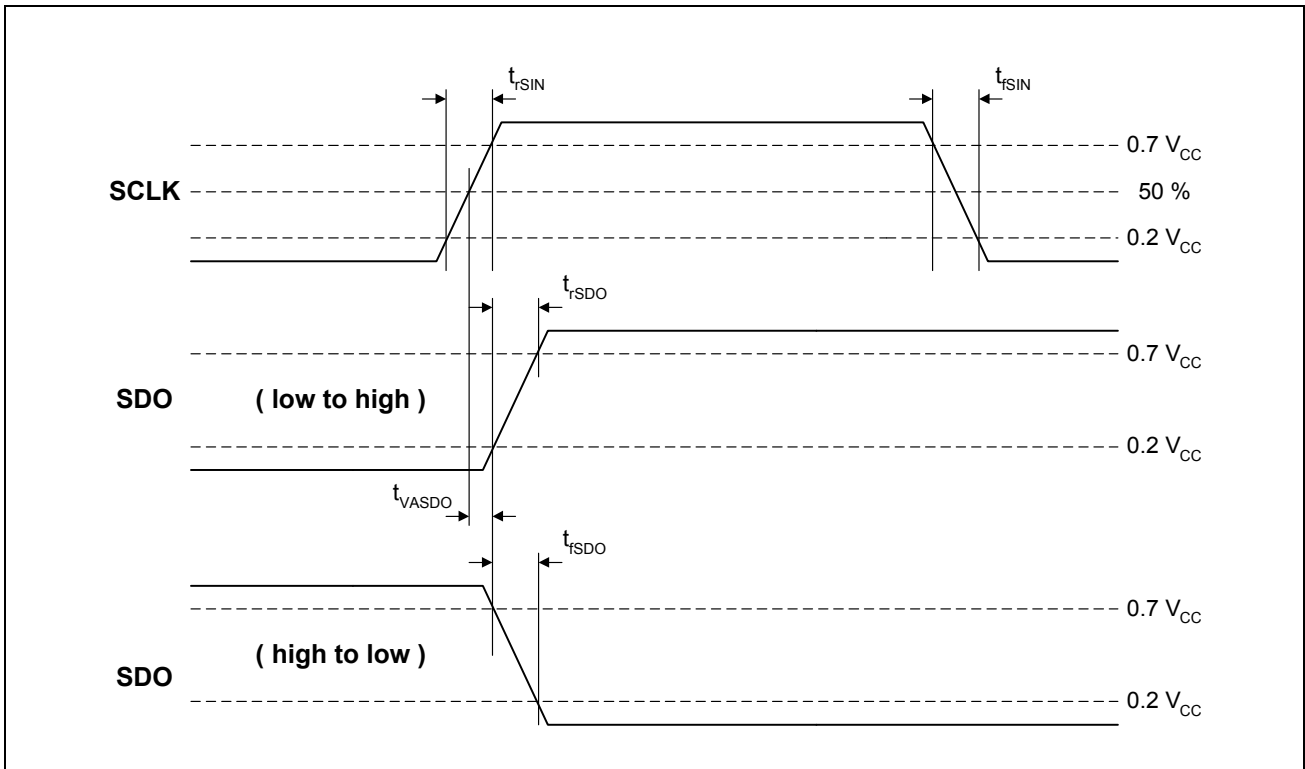

Figure 10 DO Valid Data Delay Time and Valid Time

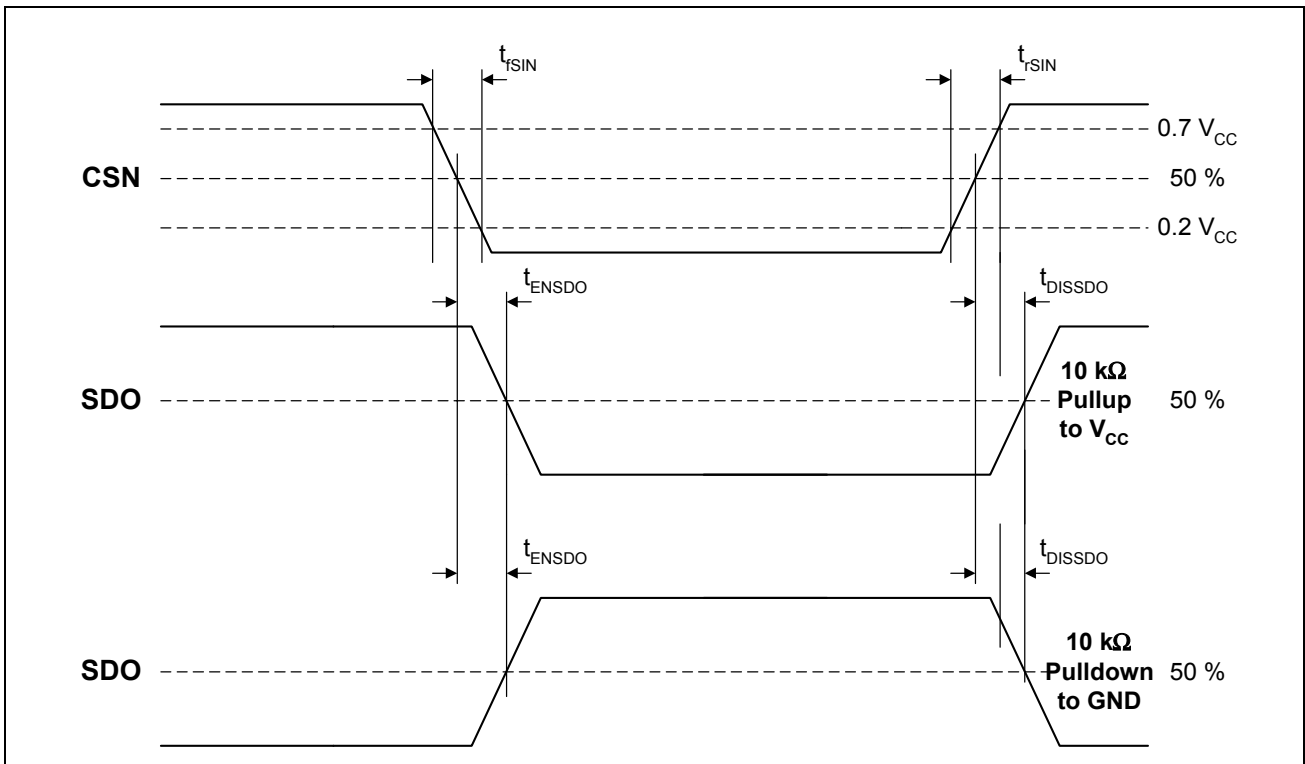

Figure 11 SDO Enable and Disable Time

## 5 Application

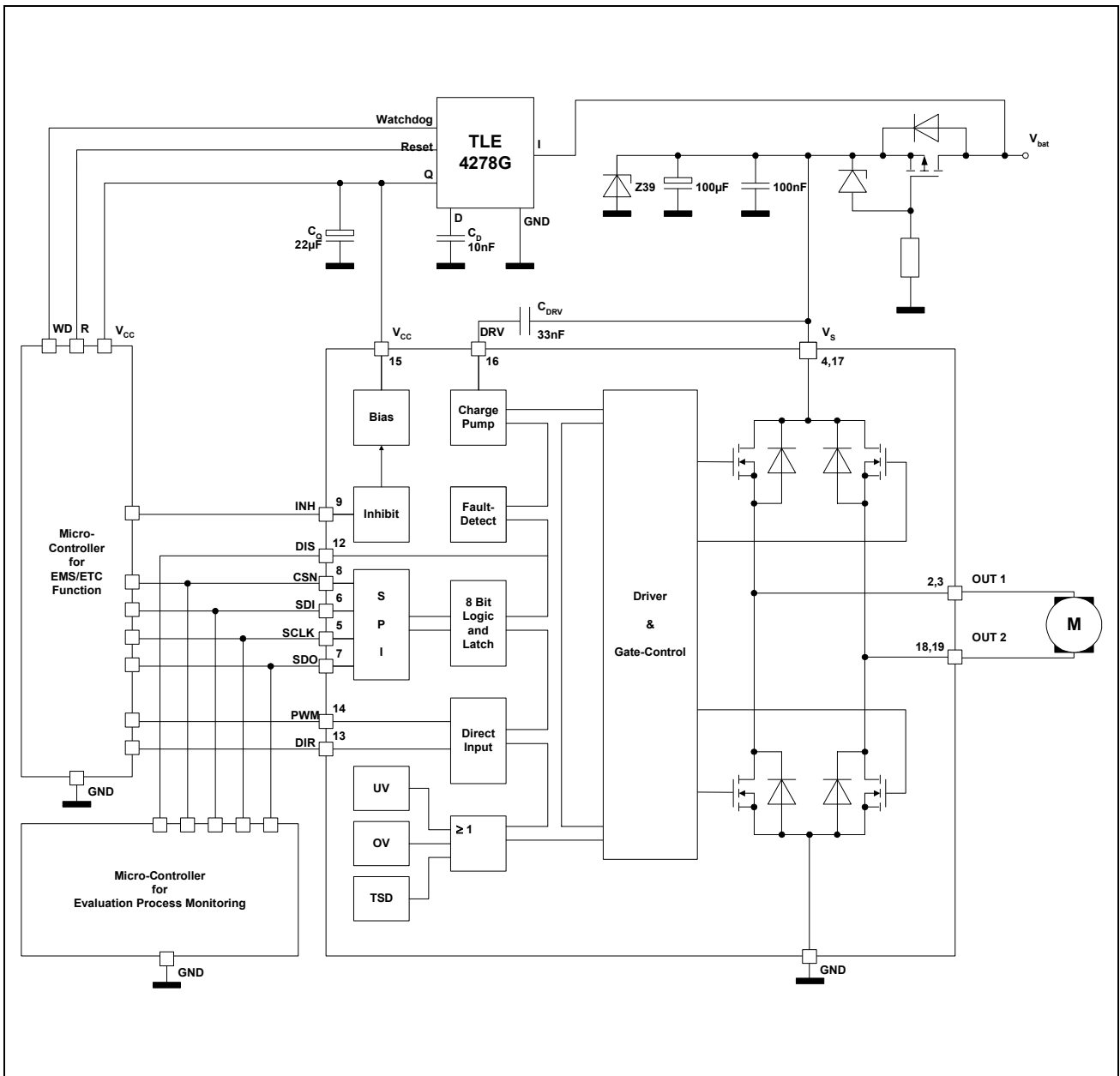
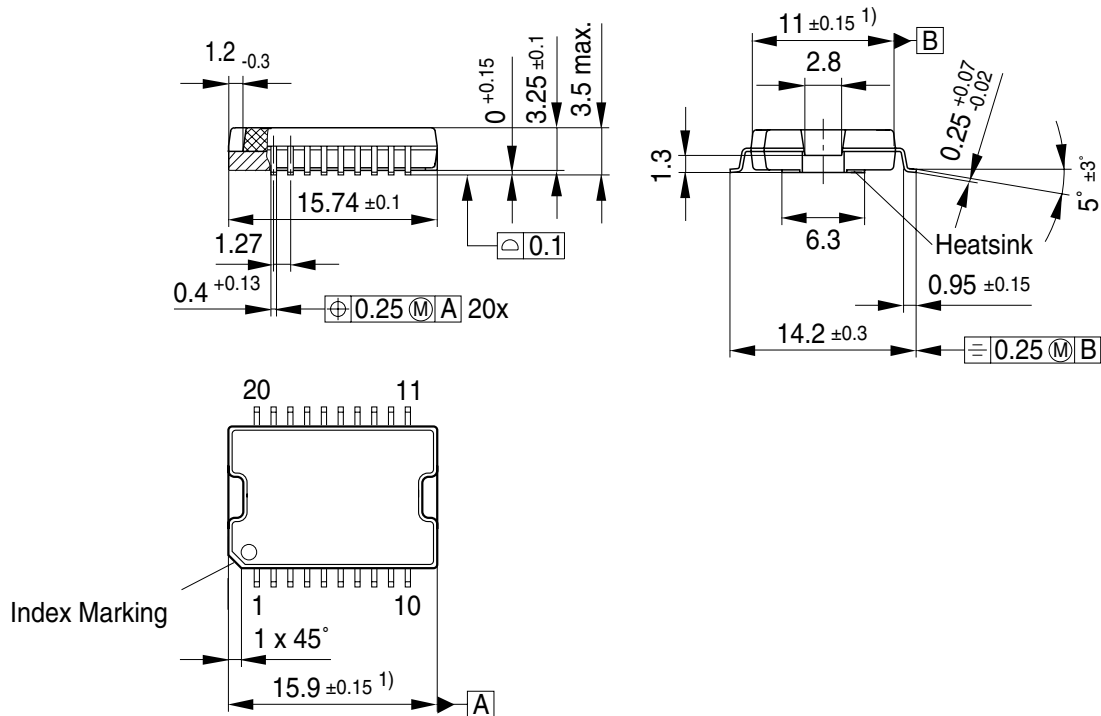

Figure 12 Application Circuit

6 Package Outlines

**PG-DSO-20-37**  
(Plastic Dual Small Outline Package)



1) Does not include plastic or metal protrusion of 0.15 max. per side

GPS05791

**Green Product (RoHS compliant)**

To meet the world-wide customer requirements for environmentally friendly products and to be compliant with government regulations the device is available as a green product. Green products are RoHS-Compliant (i.e Pb-free finish on leads and suitable for Pb-free soldering according to IPC/JEDEC J-STD-020).

You can find all of our packages, sorts of packing and others in our Infineon Internet Page “Products”: <http://www.infineon.com/products>.

SMD = Surface Mounted Device

Dimensions in mm

## 7 Revision History

Version	Date	Changes
Rev. 3.1	2007-08-01	<p>RoHS-compliant version of the TLE 6209 R</p> <ul style="list-style-type: none"><li>• All pages: Infineon logo updated</li><li>• Page 1: “AEC qualified” and “RoHS” logo added, “Green Product (RoHS compliant)” and “AEC qualified” statement added to feature list, package names changed to RoHS compliant versions, package pictures updated, ordering codes removed</li><li>• Page 28: Package name changed to RoHS compliant version, “Green Product” description added</li><li>• Revision History added</li><li>• Legal Disclaimer added</li></ul>

**Edition 2007-08-01**

**Published by  
Infineon Technologies AG  
81726 Munich, Germany**

**© 8/1/07 Infineon Technologies AG  
All Rights Reserved.**

#### **Legal Disclaimer**

The information given in this document shall in no event be regarded as a guarantee of conditions or characteristics. With respect to any examples or hints given herein, any typical values stated herein and/or any information regarding the application of the device, Infineon Technologies hereby disclaims any and all warranties and liabilities of any kind, including without limitation, warranties of non-infringement of intellectual property rights of any third party.

#### **Information**

For further information on technology, delivery terms and conditions and prices, please contact the nearest Infineon Technologies Office ([www.infineon.com](http://www.infineon.com)).

#### **Warnings**

Due to technical requirements, components may contain dangerous substances. For information on the types in question, please contact the nearest Infineon Technologies Office.

Infineon Technologies components may be used in life-support devices or systems only with the express written approval of Infineon Technologies, if a failure of such components can reasonably be expected to cause the failure of that life-support device or system or to affect the safety or effectiveness of that device or system. Life support devices or systems are intended to be implanted in the human body or to support and/or maintain and sustain and/or protect human life. If they fail, it is reasonable to assume that the health of the user or other persons may be endangered.