

SAW Duplexers

Type: **EFSD**□□□□**J**□□□□
EFSD□□□□**K**□□□□



SAW Duplexer for Cellular Telephone which incorporates highly-precise interdigitated electrodes achieves low insertion loss, high selectivity. And unique electrode material achieves high power durability thus the duplexer has wide applications to antenna duplexer circuits for cellular telephones.

■ Features

- Stable against severe conditions of vibration and shock thanks to the unique monolithic construction of the filter
- Low insertion loss and excellent selectivity
- Contributes to circuit simplification and adjustment free
- Saves the height on PC board

■ Recommended Applications

- The antenna duplexer for cellular telephone

■ Explanation of Part Numbers

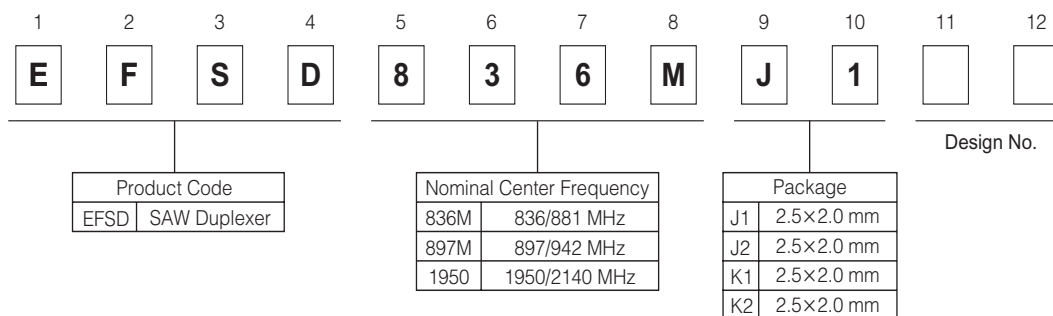

■ Ratings and Characteristics

Part No.	System	Nominal Center Frequency	Input/Output Impedance	Size	Package
EFSD836MJ1□□ EFSD836MJ2□□	CDMA UMTS Band V	836.5/881.5 MHz	UB-UB(50 Ω-50 Ω)	2.5×2.0 mm	J
EFSD1950J1□□ EFSD1950J2□□	UMTS Band I	1950/2140 MHz	UB-UB(50 Ω-50 Ω)	2.5×2.0 mm	J
EFSD897MK1□□ EFSD897MK2□□	UMTS Band VIII	897.5/942.5 MHz	UB-UB(50 Ω-50 Ω)	2.5×2.0 mm	K

* UB : Unbalance, B : Balance

■ Dimensions in mm (not to scale)

J type

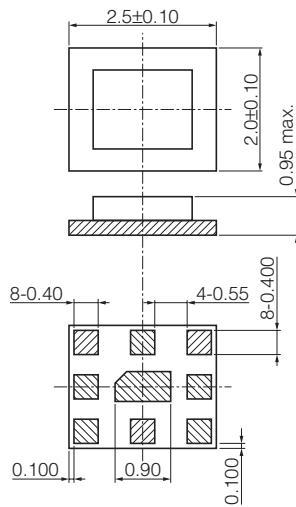

K type

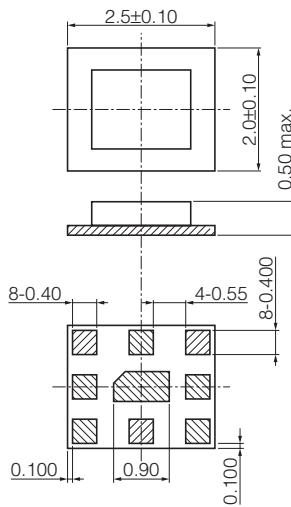

■ Packaging Methods (Taping)

● Minimum Quantity / Packing Unit

Part Number	Packaging Style	Quantity	Packaging Quantity in Carton	Carton Dimensions in mm (L×W×H)
EFSD□□□□J□□□	Embossed Carrier Taping	2000 pcs./reel	10000 pcs.	230×220×73
EFSD□□□□K□□□	Embossed Carrier Taping	2000 pcs./reel	10000 pcs.	230×220×73

● Embossed Carrier Taping

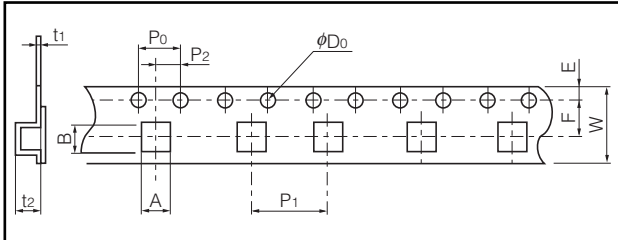

J type

Symbol	W	F	E	P_0	P_1	P_2	D_0	t_1	t_2	A	B
Dim. (mm)	8.0±0.2	3.50±0.05	1.75±0.10	4.0±0.1	4.0±0.1	2.00±0.05	$\phi 1.50^{+0.1}_{-0.1}$	0.25±0.05	1.10±0.10	2.3±0.1	2.8±0.1

K type

Symbol	W	F	E	P_0	P_1	P_2	D_0	t_1	t_2	A	B
Dim. (mm)	8.0±0.2	3.50±0.05	1.75±0.10	4.0±0.1	4.0±0.1	2.00±0.05	$\phi 1.50^{+0.1}_{-0.1}$	0.25±0.05	0.70±0.10	2.3±0.1	2.8±0.1

● Taping Reel

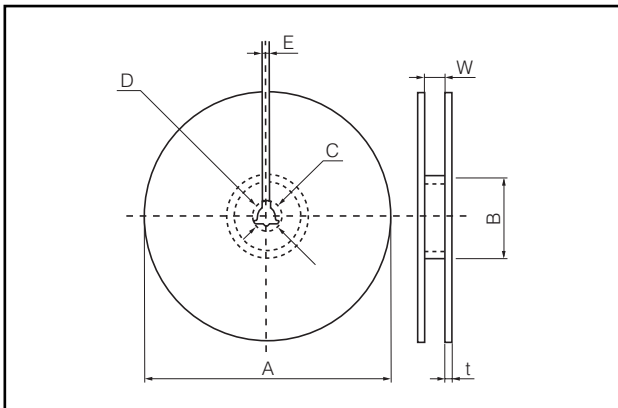

J, K type

Symbol	A	B	C	D	E	W	t
Dim. (mm)	$\phi 178 \pm 3$	$\phi 60.0 \pm 1.0$	$\phi 13.0 \pm 0.5$	$\phi 21.0 \pm 1.0$	2.0±0.5	9.0±1.0	max. 3