

## Features

- Low Cost Plastic SOT-89 Package
- Broadband Operation
- +38.5 dBm Output Intercept Point @ 250 MHz
- +19 dBm Output P1dB
- High Efficiency
- 50  $\Omega$  Input / Output Match
- 18 dB Typical Gain

## Description

M/A-COM's MAAMSS0017 driver amplifier is a GaAs MMIC which exhibits high OIP3 as well as high gain and low power consumption in a low-cost SOT-89 surface mount plastic package.

The MAAMSS0017 employs a monolithic single stage design featuring a convenient 50  $\Omega$  input / output impedance that minimizes the number of external components required. The device runs off a single +5 volt supply and draws 70 mA typically.

The MAAMSS0017 is fabricated using M/A-COM's iHBT process to realize low current and high power functionality. The process features full passivation for increased performance and reliability.

## Functional Schematic

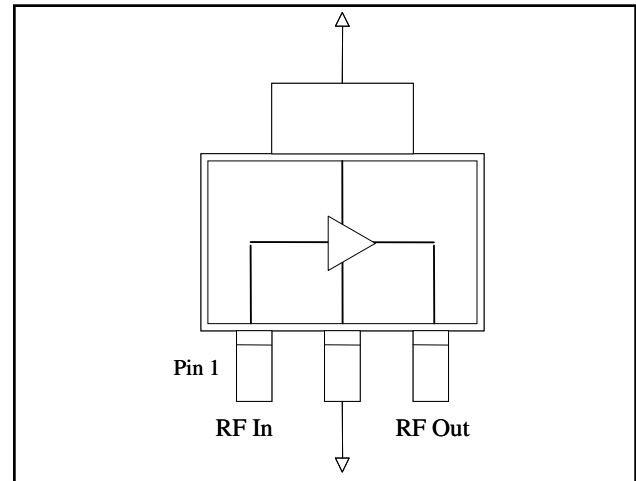

## Pin Configuration

Pin No.	Function	Pin No.	Function
1	RF In	3	RF Out/Bias
2	GND		

## Absolute Maximum Ratings <sup>4,5</sup>

Parameter	Absolute Maximum
RF Input Power <sup>6</sup>	15 dBm
Voltage	6 Volts
Junction Temperature <sup>7</sup>	+150°C
Operating Temperature	-40 °C to +85 °C
Storage Temperature	-65 °C to +150 °C

## Ordering Information <sup>1,2</sup>

Part Number	Package
MAAMSS0017TR	1000 Piece Tape and Reel
MAAMSS0017TR-3000	3000 Piece Tape and Reel
MAAMSS0017SMB	Sample Board

1. Reference Application Note M513 for reel size information.
2. All sample boards include 5 loose parts.

## Maximum Operating Conditions <sup>3</sup>

Parameter	Maximum Operating Conditions
Junction Temperature	125°C
RF Input Power	14 dBm

3. Operating at or within these conditions will ensure MTTF > 1 x 10<sup>6</sup> hours.

4. Exceeding any one or combination of these limits may cause permanent damage to this device.
5. M/A-COM does not recommend sustained operation near these survivability limits.
6. The MAAMSS0017 is designed to operate optimally at 10 dB backed off from its output P1dB. Driving the device at higher power levels could degrade performance.
7. Thermal Resistance = 110°C/W.

**Electrical Specifications:  $T_A = 25^\circ\text{C}$ ,  $V_{CC} = 5\text{ V}$ ,  $Z_0 = 50\ \Omega$ ,  $P_{IN} \leq -10\text{ dBm}$**

Parameter	Test Conditions	Units	Min	Typ	Max
Gain	250 MHz	dB	15.5	18	19.5
	50 - 600 MHz	dB	—	17	—
	600 - 1500 MHz	dB	—	12.5	—
	1500 - 2000 MHz	dB	—	10.5	—
	2000 - 2500 MHz	dB	—	8	—
Noise Figure	50 - 600 MHz	dB	—	4.8	—
	600 - 1500 MHz	dB	—	5.1	—
	1500 - 2500 MHz	dB	—	5.3	—
Input Return Loss	50 - 600 MHz	dB	—	10	—
	600 - 2500 MHz	dB	—	13	—
Output Return Loss	50 - 600 MHz	dB	—	10	—
	600 - 1500 MHz	dB	—	13	—
	1500 - 2500 MHz	dB	—	10	—
Output 1dB Compression	50 - 600 MHz	dBm	—	20	—
	600 - 2500 MHz	dBm	—	19	—
Output IP3	Two tone, $P_{IN} / \text{Tone} = -13\text{ dBm}$ , Tone spacing = 10 MHz				
	250 MHz	dBm	35	38.5	—
	50 - 600 MHz	dBm	—	37	—
Current	$V_{CC} = 5\text{ V}$		—	70	100

## PCB Configuration

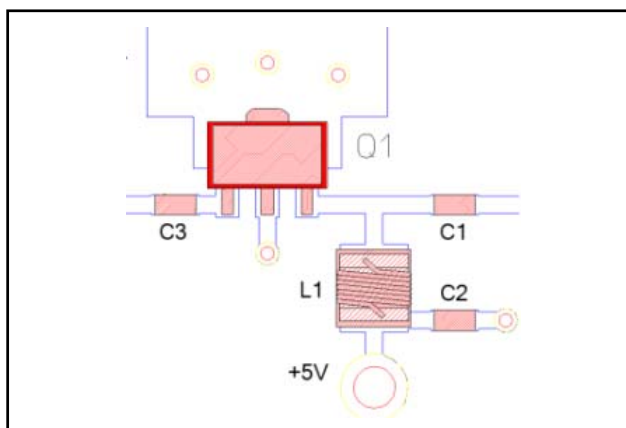

## Schematic Including Off-Chip Components

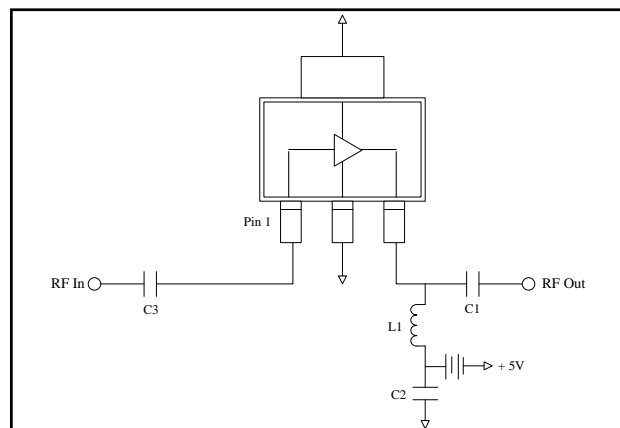

## Component List

Part	Value	Package	Manufacturer
C1	150 pF	0603	Murata
C2	0.1 $\mu\text{F}$	0603	Murata
C3	1000 pF	0603	Murata
L1	180 nH	1008	Coilcraft

## Operating the MAAMSS0017

The MAAMSS0017 can be damaged by electrostatic discharge (ESD). Use proper ESD control techniques when handling this device. To operate the MAAMSS0017, follow these steps.

1. Apply  $V_{CC}$  (5.0 V).
2. Set  $P_{IN}$ .
3. Turn off in reverse order.

• **North America** Tel: 800.366.2266 / Fax: 978.366.2266  
 • **Europe** Tel: 44.1908.574.200 / Fax: 44.1908.574.300  
 • **Asia/Pacific** Tel: 81.44.844.8296 / Fax: 81.44.844.8298  
 Visit [www.macomtech.com](http://www.macomtech.com) for additional data sheets and product information.

M/A-COM Technology Solutions Inc. and its affiliates reserve the right to make changes to the product(s) or information contained herein without notice.

## Typical Performance Curves

**Gain**

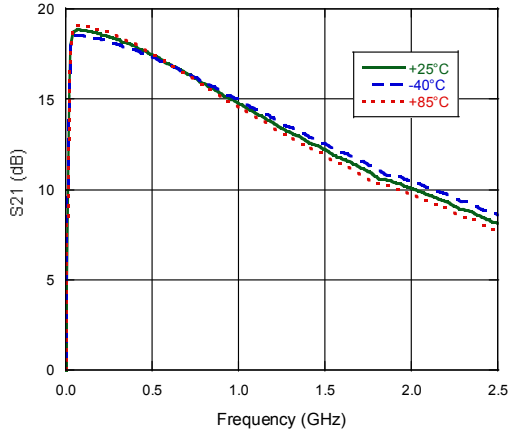

**Reverse Isolation**

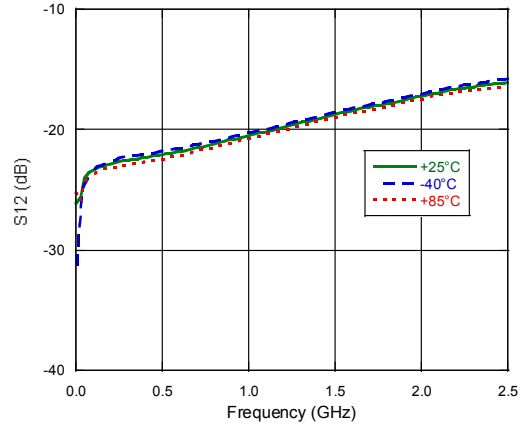

**Input Return Loss**

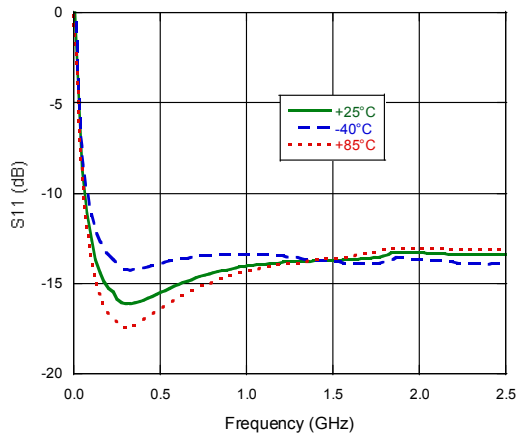

**Output Return Loss**

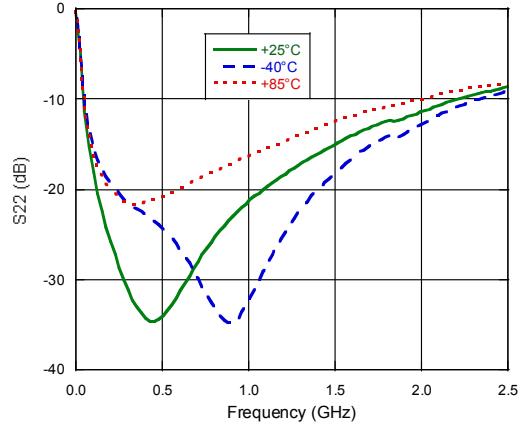

**OIP3 ( $P_{IN} = -13$  dBm / tone)**

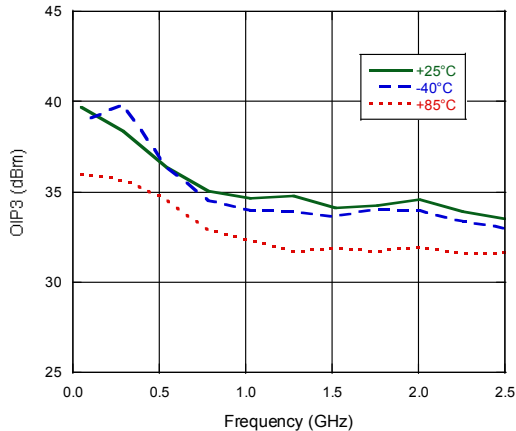

**Noise Figure**

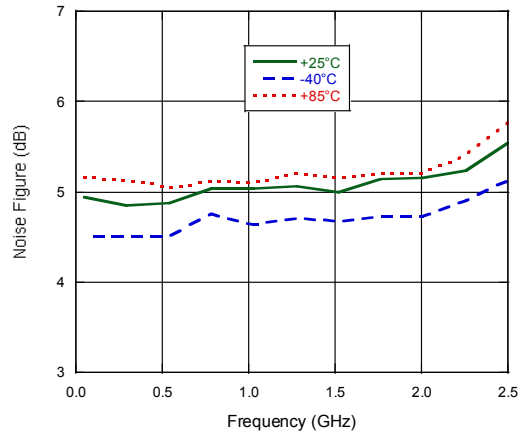

## Typical Performance Curves

### P1dB

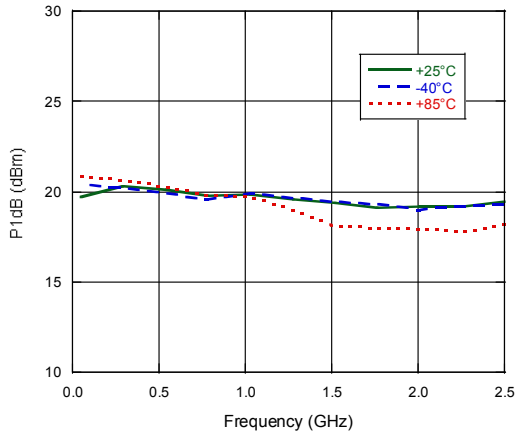

## SOT-89 Plastic Package

