

# H-Bridge Driver IC

## Features

- Compatible to very low ohmic normal level input N-Channel MOSFETs
- PWM – DIR - Interface
- PWM frequency up to 50kHz
- Operates down to 7.5 V supply voltage
- Low EMC sensitivity and emission
- Adjustable dead time with shoot through protection
- Deactivation of dead time and shoot through protection possible
- Short circuit protection for each Mosfet can be disabled and adjusted
- Driver undervoltage shut down
- Reverse polarity protection for the driver IC
- Fast disable function / Inhibit for low quiescent current
- Input with TTL characteristics
- 2 bit diagnosis
- Thermal overload warning for driver IC
- Shoot through protection
- Integrated bootstrap diodes

## Product Summary

Turn on current	$I_{Gxx(on)}$	850	mA
Turn off current	$I_{Gxx(off)}$	580	mA
Supply voltage range	$V_{Vs}$	7.5 ... 60	V
Gate Voltage	$V_{GS}$	10	V
Temperature range	$T_J$	-40...+150	°C

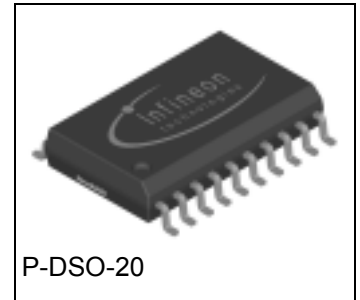

## Application

- Dedicated for DC-brush high current motor bridges in PWM control mode for 12, 24 and 42V powernet applications.
- The input structure allows an easy control of a DC-brush motor

## General Description

H-bridge driver IC for MOSFET power stages with multiple protection functions.

The TLE6184G is very similar to the TLE6281G. The major difference is that the Short Circuit protection level of the TLE6284G can be adjusted by external resistors or even disabled. The pin outs are different as well.

### Block Diagram

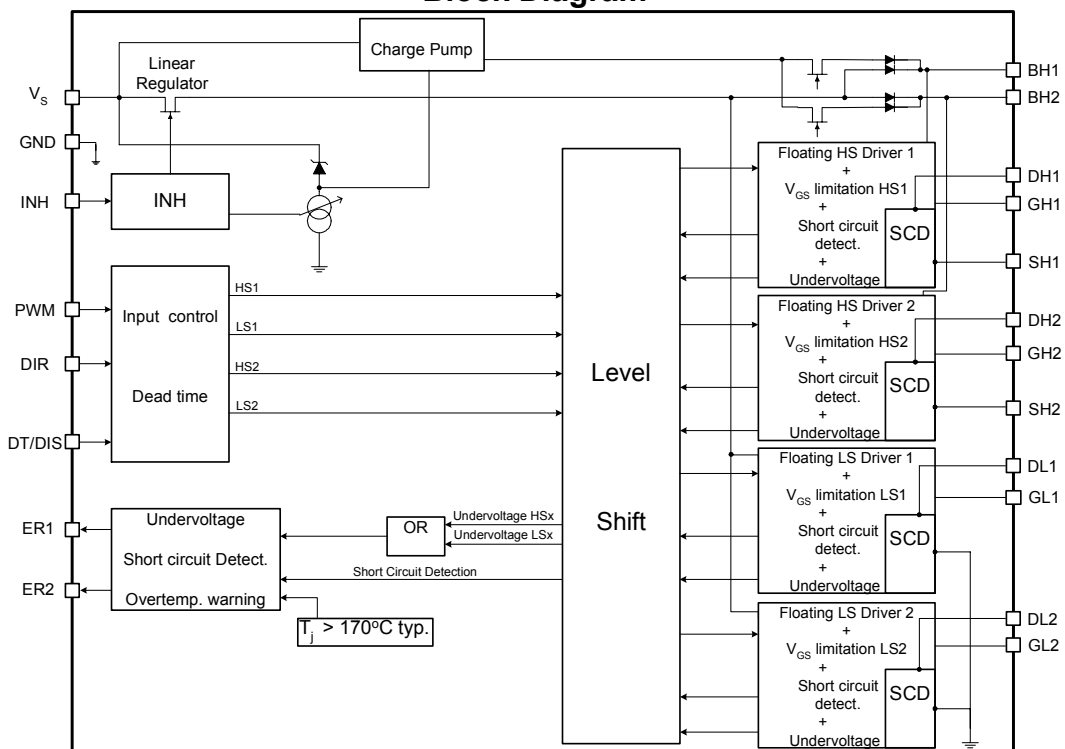

Application Block Diagram

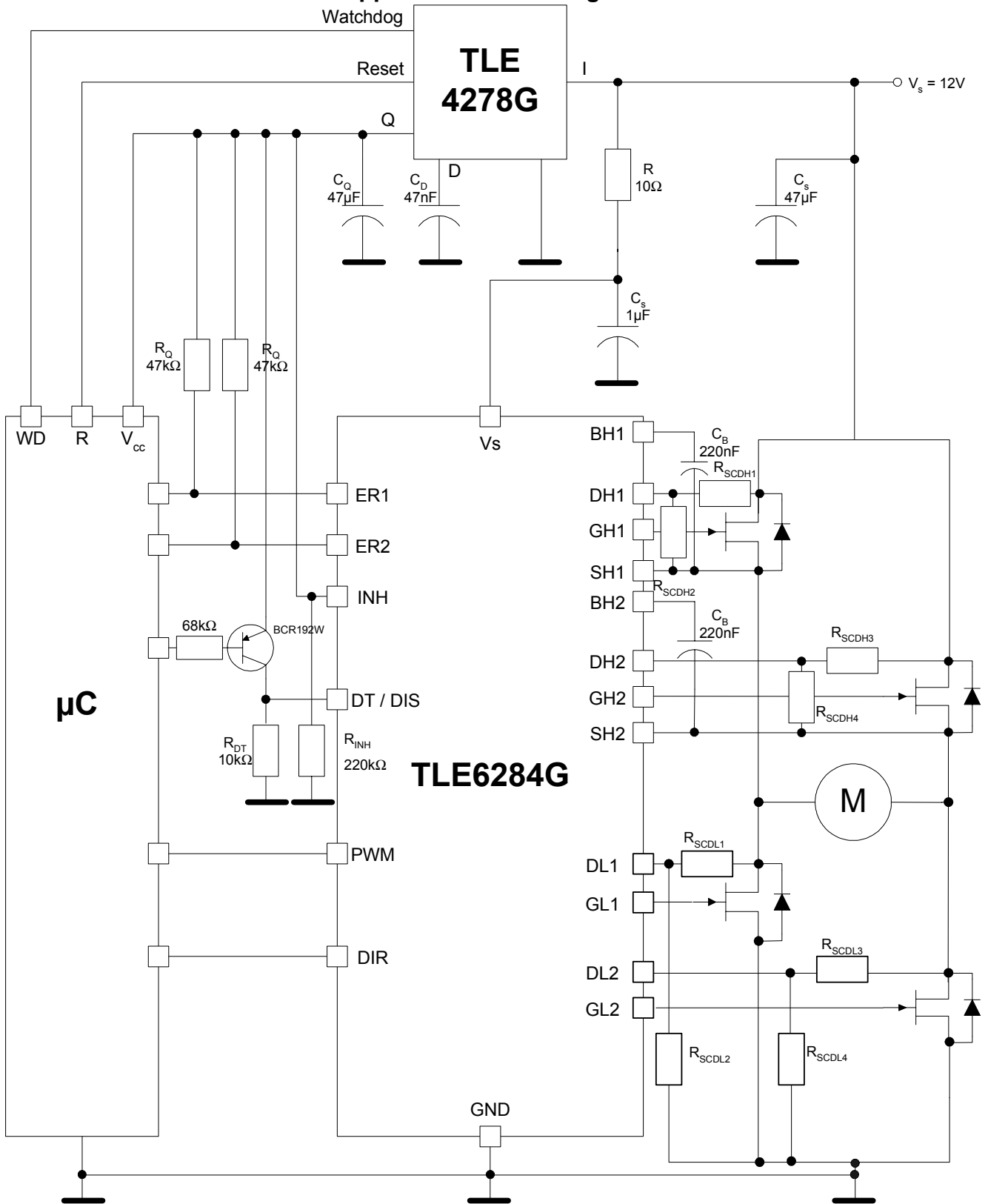

This application block diagram shows one of the possibilities to use this Driver IC. The voltage divider networks across the 4 MOSFETs (resistors  $R_{SCDxx}$ ) allow to increase the current limit threshold for Short Circuit protection. The  $R_{SCDLx}$  resistors also provide a charge path for the bootstrap capacitors. If  $R_{SCDLx}$  resistors are not used in the application, a 12k Ohm resistor should be introduced between SH1 to GND and SH2 to GND.

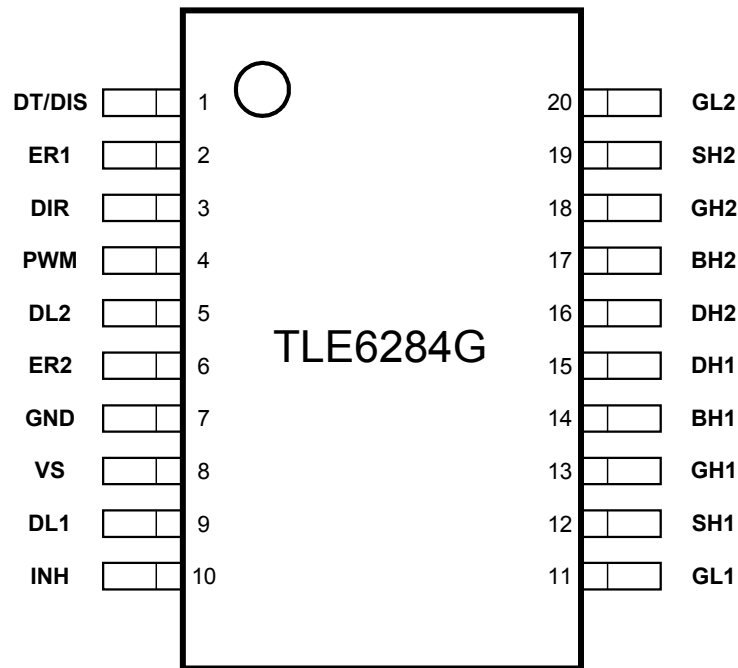

Pin	Symbol	Function
1	DT / DIS	a) Set adjustable dead time by external resistor b) Reset ERx register c) Disable output stages
2	ER1	Error flag for driver shut down
3	DIR	Control input for spinning direction of the motor
4	PWM	Control input for PWM frequency and duty cycle
5	DL2	Sense contact for short circuit detection low side 2
6	ER2	Warning flag Temperature / distinguish if short circuit or undervoltage lock out occurred
7	GND	Logic Ground
8	VS	Voltage supply
9	DL1	Sense contact for short circuit detection low side 1
10	INH	Sets complete device to sleep mode to achieve low quiescent currents
11	GL1	Output to gate low side switch 1
12	SH1	Connection to source high side switch 1
13	GH1	Output to gate high side switch 1
14	BH1	Bootstrap supply high side switch 1
15	DH1	Sense contact for short circuit detection high side 1
16	DH2	Sense contact for short circuit detection high side 2
17	BH2	Bootstrap supply high side switch 2
18	GH2	Output to gate high side switch 2
19	SH2	Connection to source high side switch 2
20	GL2	Output to gate low side switch 2

**Maximum Ratings at  $T_j = -40 \dots +150^\circ\text{C}$  unless specified otherwise**

Parameter	Symbol	Limits Values		Unit
		min	max	
Supply voltage <sup>1</sup>	$V_S$	-4	60	V
Operating temperature range	$T_j$	-40	150	$^\circ\text{C}$
Storage temperature range	$T_{\text{stg}}$	-55	150	
Max. voltage range at PWM, DIR, DT/DIS		-1	6	V
Max. voltage range at ERx		-0.3	6	V
Max. voltage range at INH	$V_{\text{INH}}$	-0.6	60	V
Max. voltage range at BHx	$V_{\text{BHx}}$	-0.3	90	V
Max. voltage range at DHx <sup>2</sup>	$V_{\text{DHx}}$	-4	75	V
Max. voltage range at GHx <sup>3</sup>	$V_{\text{GHx}}$	-7	86	V
Max. voltage range at SHx <sup>3</sup>	$V_{\text{SHx}}$	-7	75	V
Max. voltage range at GLx	$V_{\text{GLx}}$	-2	12	V
Max. voltage range at DLx	$V_{\text{DLx}}$	-7	75	V
Max. voltage difference BHx – SHx	$V_{\text{BHx}} - V_{\text{SHx}}$	-0.3	17	V
Max. voltage difference Gxx – Sxx	$V_{\text{Gxx}} - V_{\text{Sxx}}$	-0.3	11	V
Power dissipation (DC) @ $T_A = 125^\circ\text{C}$ / min. footprint	$P_{\text{tot}}$	--	0.33	W
Power dissipation (DC) @ $T_A = 85^\circ\text{C}$ / min. footprint	$P_{\text{tot}}$	--	0.85	W
Electrostatic discharge voltage (Human Body Model) according to MIL STD 883D, method 3015.7 and EOS/ESD assn. standard S5.1 – 1993	$V_{\text{ESD}}^4$	--	2	kV
Thermal resistance junction - ambient (minimal footprint with thermal vias)	$R_{\text{thJA}}$	--	75	K/W
Thermal resistance junction - ambient (6 cm <sup>2</sup> )	$R_{\text{thJA}}$	--	75	K/W

**Functional range**

Parameter and Conditions at $T_j = -40 \dots +150^\circ\text{C}$ , unless otherwise specified	Symbol	Values		Unit
		min	max	
Supply voltage	$V_S$	7.5	60	V
Operating temperature range	$T_j$	-40	150	$^\circ\text{C}$
Max. voltage range at PWM, DIR, DT/DIS		-0.3	5.5	V
Max. voltage range at ERx		-0.3	5.5	V
Max. voltage range at INH	$V_{\text{INH}}$	-0.6	60	V
Max. voltage range at BHx	$V_{\text{BHx}}$	-0.3	90	V
Max. voltage range at DHx <sup>2</sup>	$V_{\text{DHx}}$	-4	75	V
Max. voltage range at GHx <sup>3</sup>	$V_{\text{GHx}}$	-7	86	V
Max. voltage range at SHx <sup>3</sup>	$V_{\text{SHx}}$	-7	75	V

<sup>1</sup> With external resistor ( $\geq 10 \Omega$ ) and capacitor

<sup>2</sup> The min value -4V is reduced to  $-(V_{\text{BHx}} - V_{\text{SHx}})$  in case of bootstrap voltages  $V_{\text{BHx}} - V_{\text{SHx}} < 4\text{V}$

<sup>3</sup> The min value -7V is reduced to  $-(V_{\text{BHx}} - V_{\text{SHx}} - 1\text{V})$  in case of bootstrap voltages  $V_{\text{BHx}} - V_{\text{SHx}} < 8\text{V}$

<sup>4</sup> All test involving Gxx pins  $V_{\text{ESD}} = 1 \text{ kV!}$

Max. voltage range at DLx <sup>3</sup>	V <sub>DLx</sub>	-7	75	V
Max. voltage range at GLx	V <sub>GLx</sub>	-2	12	V
Max. voltage difference BHx - SHx	V <sub>BHx</sub> -V <sub>SHx</sub>	-0.3	12	V
Max. voltage difference GHx – SHx	V <sub>Gxx</sub> -V <sub>Sxx</sub>	-0.3	11	V
PWM frequency	F <sub>PWM</sub>	0	50	kHz
Minimum on time external lowside switch – static condition @ 20 kHz; Q <sub>Gate</sub> = 200nC	t <sub>p(min)</sub>	--	2	µs

## Electrical Characteristics

Parameter and Conditions at T <sub>j</sub> = -40...150°C, unless otherwise specified and supply voltage range V <sub>S</sub> = 7.5 ... 60V; f <sub>PWM</sub> = 20kHz	Symbol	Values			Unit
		min	typ	max	

### Static Characteristics

Low level output voltage (V <sub>GSxx</sub> ) @ I=10mA	ΔV <sub>LL</sub>	--	60	150	mV
High level output voltage (V <sub>GSxx</sub> ) @ I=-10mA; V <sub>S</sub> ≥11.5V	ΔV <sub>HL</sub>	8	10	11	V
High level output voltage (V <sub>GSxx</sub> ) @ I=-10mA; V <sub>S</sub> <11.5V	ΔV <sub>HL</sub>	--	V <sub>S</sub> -1.5	--	V
Supply current at VS (device disabled) @ V <sub>bat</sub> = V <sub>S</sub> =42V R <sub>DT</sub> =400kΩ	I <sub>VS(dis)42V</sub>	--	4	8	mA
Quiescent current at VS (device inhibited) @ V <sub>bat</sub> = V <sub>S</sub> =14V R <sub>DT</sub> =400kΩ R <sub>SCDL1</sub> +R <sub>SCDL2</sub> = R <sub>SCDL3</sub> +R <sub>SCDL4</sub> =12kΩ	I <sub>VS(inh)14V</sub>	--	0.6	1.5	mA
Quiescent current at VS (device inhibited) @ V <sub>bat</sub> = V <sub>S</sub> =42V R <sub>DT</sub> =400kΩ R <sub>SCDL1</sub> +R <sub>SCDL2</sub> = R <sub>SCDL3</sub> +R <sub>SCDL4</sub> =12kΩ	I <sub>VS(inh)42V</sub>	--	0.6	1.5	mA
Supply current at VS @ V <sub>bat</sub> = V <sub>S</sub> =14V, f <sub>PWM</sub> = 20kHz (Outputs open)	I <sub>VS(open)14V</sub>	--	7	15	mA
Supply current at VS @ V <sub>bat</sub> = V <sub>S</sub> =14V, f <sub>PWM</sub> = 50kHz (Outputs open)	I <sub>VS(open)14V</sub>	--	7	15	mA
Supply current at VS @ V <sub>bat</sub> = V <sub>S</sub> =42V, f <sub>PWM</sub> = 20kHz (Outputs open)	I <sub>VS(open)42V</sub>	--	7	15	mA
Low level input voltage	V <sub>IN(LL)</sub>	--	--	1.0	V
High level input voltage	V <sub>IN(HL)</sub>	2.0	--	--	V
Input hysteresis	ΔV <sub>IN</sub>	100	170	--	mV
Inhibit trip level	V <sub>INH</sub>	1.3	2	3	V

**Dynamic characteristics (pls. see test circuit and timing diagram)**

Turn on current @ $V_{Gxx} - V_{Sxx} = 0V$ ; $T_j = 25^\circ C$ @ $V_{Gxx} - V_{Sxx} = 4V$ ; $T_j = 125^\circ C$ @ $C_{Load} = 22nF$ ; $R_{load} = 0\Omega$	$I_{Gxx(on)}$	--	850	--	mA
		--	700	--	
Turn off current @ $V_{Gxx} - V_{Sxx} = 10V$ ; $T_j = 25^\circ C$ @ $V_{Gxx} - V_{Sxx} = 4V$ ; $T_j = 125^\circ C$ @ $C_{Load} = 22nF$ ; $R_{load} = 0\Omega$	$I_{Gxx(off)}$	--	580	--	mA
		--	300	--	
Dead time (adjustable) @ $R_{DT} = 1 k\Omega$ @ $R_{DT} = 10 k\Omega$ @ $R_{DT} = 50 k\Omega$ @ $R_{DT} = 200 k\Omega$ @ $C_{Load} = 10nF$ ; $R_{load} = 1\Omega$	$t_{DT}$	--	0.01	--	$\mu s$
		0.05	0.20	0.38	
		0.40	1.0	2.50	
		--	3.1	--	
Rise time @ $C_{Load} = 10nF$ ; $R_{load} = 1\Omega$ (20% to 80%)	$t_{rise}$	--	100	300	ns
Fall time @ $C_{Load} = 10nF$ ; $R_{load} = 1\Omega$ (80% to 20%)	$t_{fall}$	--	150	440	ns
Disable propagation time @ $C_{Load} = 10nF$ ; $R_{load} = 1\Omega$	$t_{P(DIS)}$	3.6	5	7	$\mu s$
Reset time of diagnosis @ $C_{Load} = 10nF$ ; $R_{load} = 1\Omega$	$t_{P(CL)}$	1	2	3.1	$\mu s$
Input propagation time (low side turns on, 0% to 10%)	$t_{P(ILN)}$	--	250	500	ns
Input propagation time (low side turns off, 100% to 90%)	$t_{P(ILF)}$	--	110	500	ns
Input propagation time (high side turns on, 0% to 10%)	$t_{P(IHN)}$	--	200	500	ns
Input propagation time (high side turns off, 100% to 90%)	$t_{P(IHF)}$	--	130	500	ns
Input propagation time difference (all channels turn on)	$t_{P(Diff)}$	20	50	70	ns
Input propagation time difference (all channels turn off)	$t_{P(Diff)}$	--	25	50	ns
Input propagation time difference (one channel; low on – high off)	$t_{P(Diff)}$	--	120	180	ns
Input propagation time difference (one channel; high on – low off)	$t_{P(Diff)}$	--	100	180	ns
Input propagation time difference (all channels; low on – high off)	$t_{P(Diff)}$	--	120	180	ns
Input propagation time difference (all channels; high on – low off)	$t_{P(Diff)}$	--	100	180	ns

**Test Circuit and Timing Diagram**

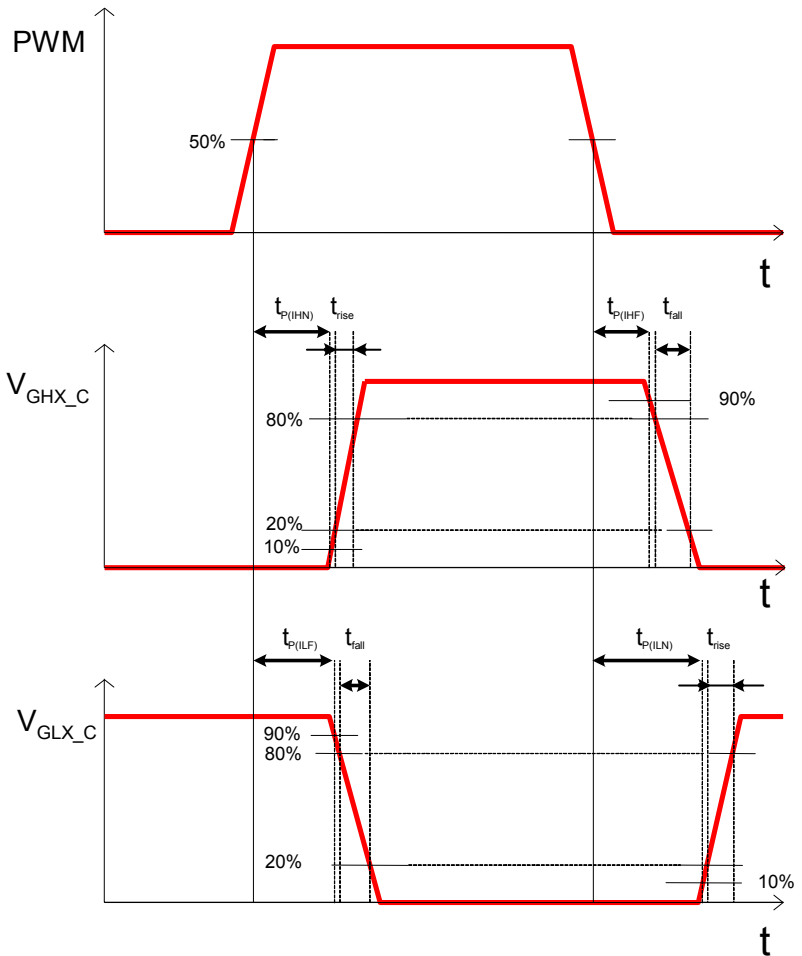
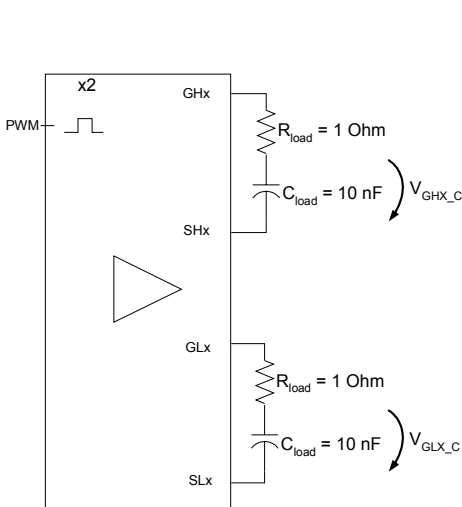

**Test Conditions :**

Junction temperature  $T_j = -40 \dots 150^\circ\text{C}$

Supply voltage range  $V_s = 7.5 \dots 60\text{V}$

PWM frequency  $f_{\text{PWM}} = 20 \text{ kHz}$

**Diagnosis and Protection Functions**

Parameter and Conditions at $T_j = -40 \dots 150^\circ\text{C}$ , unless otherwise specified and supply voltage range $V_s = 7.5 \dots 60\text{V}$ ; $f_{\text{PWM}} = 20\text{kHz}$	Symbol	Values			Unit
		min	typ	max	
Overtemperature warning	$T_{j(\text{OV})}$	150	170	190	$^\circ\text{C}$
Hysteresis for overtemperature warning	$\Delta T_{j(\text{OV})}$	--	20	--	$^\circ\text{C}$
Short circuit protection filter time	$t_{\text{SCP}(\text{off})}$	6	9	12	$\mu\text{s}$
Short circuit criteria ( $V_{\text{DS}}$ of Mosfets)	$V_{\text{DS}(\text{SCP})}$				
For Low sides		0.5	0.75	1.0	V
For High sides		0.45	0.75	1.05	V
Disable input level	$V_{\text{DIS}}$	3.3	3.7	4.0	V
Disable input hysteresis	$\Delta V_{\text{DIS}}$	--	180	--	mV
Error level @ 1.6mA $I_{\text{ERx}}$	$V_{\text{ERx}}$	--	--	1.0	V
Under voltage lock out for highside output – bootstrap voltage	$V_{\text{BHx}(\text{uVlo})}$	--	3.7	4.6	V
Under voltage lock out for lowside output – supply voltage	$V_{\text{Vs}(\text{uVlo})}$	--	4.8	5.9	V

**Remarks:**

**Default status of input pins:**

To assure a defined status of the logic input pins in case of disconnection, these pins are internally secured by pull up / pull down current sources with approx. 20µA. The high voltage proof input INH should be secured by an external pull down resistor close to the device. The following table shows the default status of the logic input pins.

Input pin	Default status
PWM and DIR	Low (= break in high side)
DT/DIS (active high)	High

**Definition:**

In this datasheet a duty cycle of 98% means that the GLx pin is 2% of the PWM period in high condition.

Remark: Please consider the influence of the dead time and the propagation time differences for the input duty cycle

**Functional description**

**Description of Dead Time Pin / Disable Pin / Reset**

This pin allows to adjust the internal generated dead time. The dead time protects the external highside and lowside Mosfets in the same halfbridge against a lowohmic connection between battery and GND and the resulting cross current through these Mosfets. The adjustable dead time allows to minimize the power dissipation caused by the current flowing through the body diode during switching the halfbridge.

In addition this pin allows to reset the diagnosis registers without shut down of any output stage as well as the possibility to shut down all outputs simultaneously.

Condition of DT/DIS pin	Function
0 - 3.5V	Adjust dead time between 10ns and 3.1µs
> 4V	a) Reset of diagnosis register if DT/DIS voltage is higher than 4V for a time between 3.1µs and 3.6µs b) Shut down of output stages if DT/DIS voltage is higher than 4V for a time above 7µs (Active pull down of gate voltage)

**Description of Inhibit functionality**

In automotive applications which are permanently connected to the battery line, it is very important to reduce the current consumption of the single devices. Therefore the TLE6284G offers an inhibit mode to put the device to sleep and assure very low quiescent currents. To deactivate the inhibit mode the INH pin has to be set to high. This can be done by connecting this pin to voltages between 3.3 and 60V without external protection. An inhibit mode means a complete reinitialisation of the device.

**Description of Diagnosis**

The two ERx pins are open collector outputs and have to be pulled up with external pull up resistors to 5V. In normal conditions both ERx signals are high. In case of shutdown of any



output stage the ER1 is pulled down. This shut down can be caused by undervoltage or short circuit. In this condition ER2 indicates the reason for the shut down.

Condition of ER1 pin	Condition of ER2 pin	Function
5V	5V	no errors
5V	0V	overtemperature warning of driver IC
0V	5V	Shut down of any output stage caused by short circuit
0V	0V	Shut down of any output stage caused by undervoltage

## Recommended Start-up procedure

The following procedure is recommended whenever the Driver IC is powered up:

- Disable the Driver IC via DT/DIS pin
- Wait until the bootstrap capacitors of High Side MOSFET  $C_{Bx}$  are charged (the waiting time depends on application conditions, e.g.  $C_{Bx}$  and  $R_{Bx}$ )
- Enable the Driver IC via DT/DIS pin
- Start the operation by applying the desired pulse patterns. Do not apply any pulse patterns to the PWM or DIR pin, before the  $C_{Bx}$  capacitors are charged up.

## Short Circuit protection

The current threshold limit to activate the Short Circuit protection function can be adjusted to larger values, it can not be adjusted to lower values. This can be done by external resistors to form voltage dividers across the “sense element” (pls. see Application block diagram on pg. 2), consisting of the Drain-Source-Terminals, a fraction of the PCB trace and – in some cases – current sense resistors (used by the  $\mu C$  not by the Driver IC).

The Short Circuit protection can be disabled for the High Side MOSFETs by shorting DH1 with SH1 and DH2 with SH2 on the PCB; in this case the DHx pins may not be connected to the Drains of the associated MOSFETs. To disable Short Circuit protection for the Low Side MOSFETs the DL1 and DL2 pin should be connected to the Driver IC’s Ground.

## Shut down of the driver

A shut down can be caused by undervoltage or short circuit.

A short circuit will shut down only the affected Mosfet until a reset of the error register by a disable of the driver occurs. A shut down due to short circuit will occur only when the Short Circuit criteria  $V_{DS(SCP)}$  is met for a duration equal to or longer than the Short Circuit filter time  $t_{SCP(off)}$ . Yet, the exposure to or above  $V_{DS(SCP)}$  is not counted or accumulated. Hence, repetitive Short Circuit conditions shorter than  $t_{scp(off)}$  will not result in a shut down of the affected MOSFET.

An undervoltage shut down shuts only the affected output down. The affected output will auto restart after the undervoltage situation is over.

## Operation at $V_s < 12V$

If  $V_s < 11.5V$  the gate voltage will not reach 10V. It will reach approx  $V_s - 1.5V$ , dependent on duty cyle, bootstrap capacitor, total gate charge of the external Mosfet and switching frequency.

### Operation at different voltages for Vs, DH1 and DH2

If DH1 and DH2 are used with a voltage higher than Vs, a duty cycle of 100% can not be guaranteed. In this case the driver is acting like a normal driver IC based on the bootstrap principle. This means that after a maximum "On" time of the highside switch of more than 1ms a refresh pulse to charge the bootstrap capacitor of about 1µs is needed to avoid undervoltage lock out of this output stage.

### Operation at extreme duty cycle:

The integrated charge pump allows an operation at 100% duty cycle. The charge pump is strong enough to replace leakage currents during "on"-phase of the highside switch. The gate charge for fast switching of the highside switches is supplied by the bootstrap capacitors. This means, that the bootstrap capacitor needs a minimum charging time of about 1µs, if the highside switch is operated in PWM mode (e.g. with 20kHz a maximum duty cycle of 96% can be reached). The exact value for the upper limit is given by the RC time formed by the impedance of the internal bootstrap diode and the capacitor formed by the external Mosfet ( $C_{\text{Mosfet}} = Q_{\text{Gate}} / V_{\text{GS}}$ ). The size of the bootstrap capacitor has to be adapted to the external MOSFET the driver IC has to drive. Usually the bootstrap capacitor is about 10-20 times bigger than  $C_{\text{Mosfet}}$ . External components at the Vs Pin have to be considered, too. The charge pump is active when the highside switch is "ON" and the voltage level at the SHx is higher than 4V. Only under these conditions the bootstrap capacitor is charged by the charge pump.

### Estimation of power loss within the Driver IC

The power loss within the Driver IC is strongly dependent on the use of the driver and the external components. Nevertheless a rough estimation of the worst case power loss is possible. Worst case calculation is:

$$P_{Loss} = (Q_{gate} * n * const * f_{PWM} + I_{VS(open)}) * V_{Vs} - P_{RGate}$$

With:

$P_{Loss}$  = Power loss within the Driver IC

$f_{PWM}$  = Switching frequency

$Q_{gate}$  = Total gate charge of used MOSFETs at 10V  $V_{GS}$

$n$  = Number of switched MOSFETs

const = Constant considering some leakage current in the driver (about 1.2)

$I_{VS(open)}$  = Current consumption of driver without connected Mosfets during switching

$V_{Vs}$  = Voltage at  $V_s$

$P_{RGate}$  = Power dissipation in the external gate resistors

This value can be reduced dramatically by usage of external gate resistors.

Estimated Power Loss  $P_{Loss}$  within the Driver IC  
for different supply voltages  $V_s$   
at  $Q_G = 100nC @ V_{GS} = 10V$

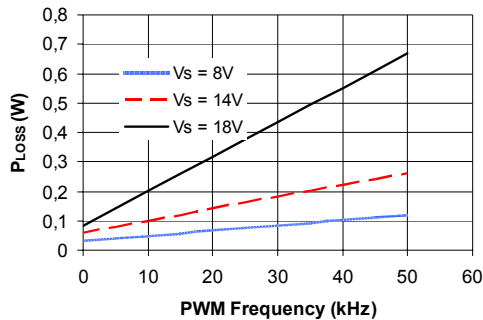

Estimated Power Loss  $P_{Loss}$  within the Driver IC  
for different gate charges  $Q_G$   
at supply voltage  $V_s = 14V$

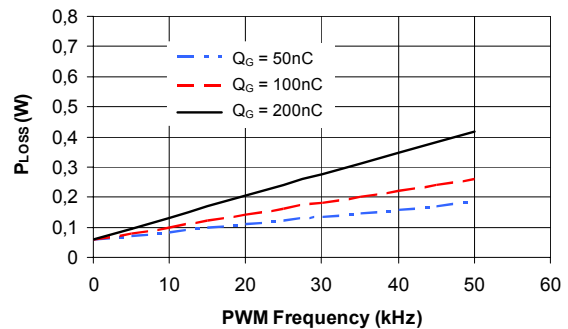

#### Conditions :

Junction temperature  $T_j = 25^\circ C$

Number of switched MOSFET  $n = 2$

Power dissipation in the external gate resistors  $P_{RGate} = 0,2 * P_{Loss}$

Gate Drive characteristics

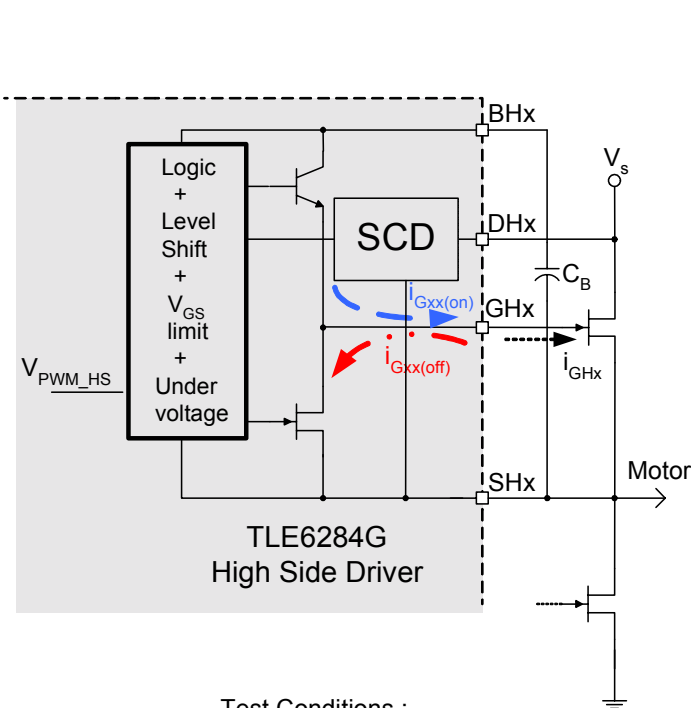

Test Conditions :  
 - Turn On :  $V_{GS} = 0V, T_j = 25^\circ C$   
 - Turn Off :  $V_{GS} = 10V, T_j = 25^\circ C$

This figure represents the simplified internal circuit of one high side gate drive. The drive circuit of the low sides look similar.

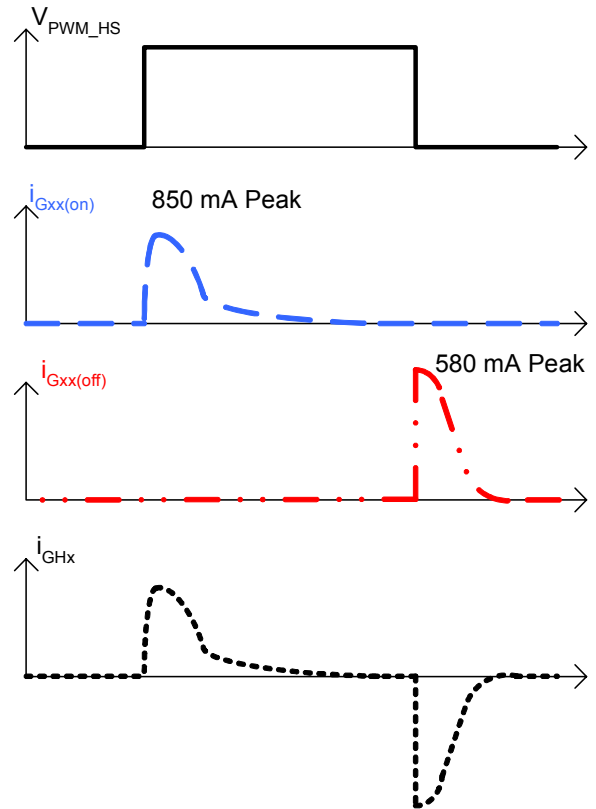

This figure illustrates typical voltage and current waveforms of the high side gate drive; the associated waveforms of the low side drives look similar.

**Truth Table**

Input			Conditions			Output driver IC						Output Bridge	
DIR	PWM	DT / DIS	UV	OT	SC	GH <sub>1</sub>	GL <sub>1</sub>	GH <sub>2</sub>	GL <sub>2</sub>	ER <sub>1</sub>	ER <sub>2</sub>	Out1	Out2
0	1	<3.5V	0	0	0	1	0	0	1	5V	5V	1	0
0	0	<3.5V	0	0	0	1	0	1	0	5V	5V	1	1
1	1	<3.5V	0	0	0	0	1	1	0	5V	5V	0	1
1	0	<3.5V	0	0	0	1	0	1	0	5V	5V	1	1
0	1	<3.5V	1	0	0	B	0	0	B	C	D	1 <sup>A</sup>	0 <sup>A</sup>
0	0	<3.5V	1	0	0	B	0	B	0	C	D	1 <sup>A</sup>	1 <sup>A</sup>
1	1	<3.5V	1	0	0	0	B	B	0	C	D	0 <sup>A</sup>	1 <sup>A</sup>
1	0	<3.5V	1	0	0	B	0	B	0	C	D	1 <sup>A</sup>	1 <sup>A</sup>
0	1	<3.5V	0	1	0	1	0	0	1	5V	0V	1	0
0	0	<3.5V	0	1	0	1	0	1	0	5V	0V	1	1
1	1	<3.5V	0	1	0	0	1	1	0	5V	0V	0	1
1	0	<3.5V	0	1	0	1	0	1	0	5V	0V	1	1
0	1	<3.5V	0	0	1	E	0	0	E	F	5V	1 <sup>A</sup>	0 <sup>A</sup>
0	0	<3.5V	0	0	1	E	0	E	0	F	5V	1 <sup>A</sup>	1 <sup>A</sup>
1	1	<3.5V	0	0	1	0	E	E	0	F	5V	0 <sup>A</sup>	1 <sup>A</sup>
1	0	<3.5V	0	0	1	E	0	E	0	F	5V	1 <sup>A</sup>	1 <sup>A</sup>
X	X	X	X	X	X	0	0	0	0	5V	5V	T	T
X	X	>4V	X	X	X	0	0	0	0	5V	5V	T	T

- A) Tristate when affected by undervoltage shut down or short circuit
- B) 0 when affected; 1 when not affected; self recovery
- C) 0V when output does not correspond to input patterns; 5V when output corresponds to input patterns
- D) Is an output affected by undervoltage ER2 is 0V
- E) 0 when affected– the outputs of the affected halfbridge are shut down and stay latched until reset; 1 when not affected
- F) 0V when output does not correspond to input patterns – the outputs of the affected half-bridge are shut down and stay latched until reset; 5V when output corresponds to input patterns.
- T) Tristate
- X) Condition has no influence

Remark: To generate fast decay control mode, set PWM to 1 and send pwm-pattern to DIR input.

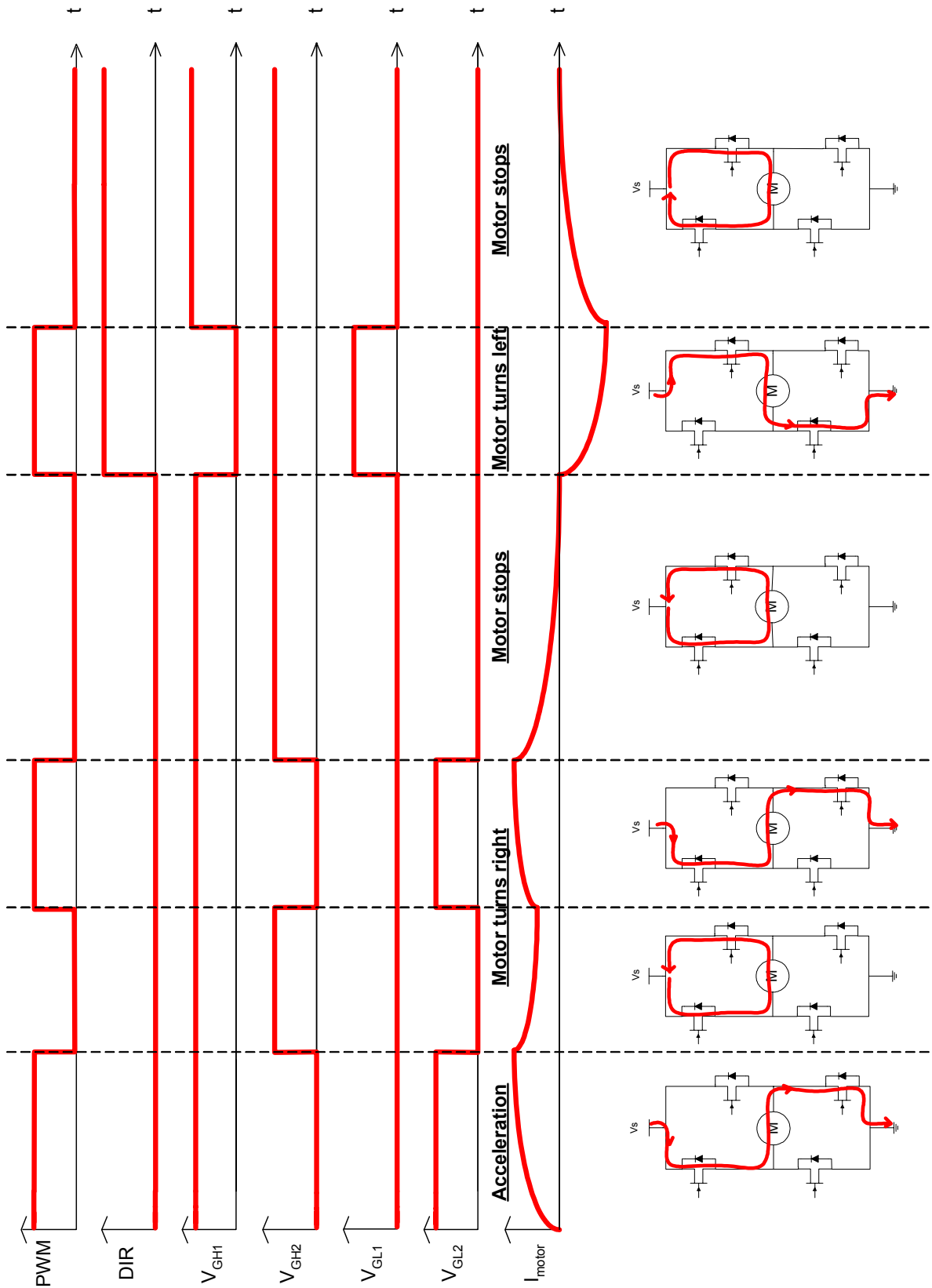

## Package and Ordering Code

(all dimensions in mm)<sup>5</sup>

Package Code

**P-DSO 20**

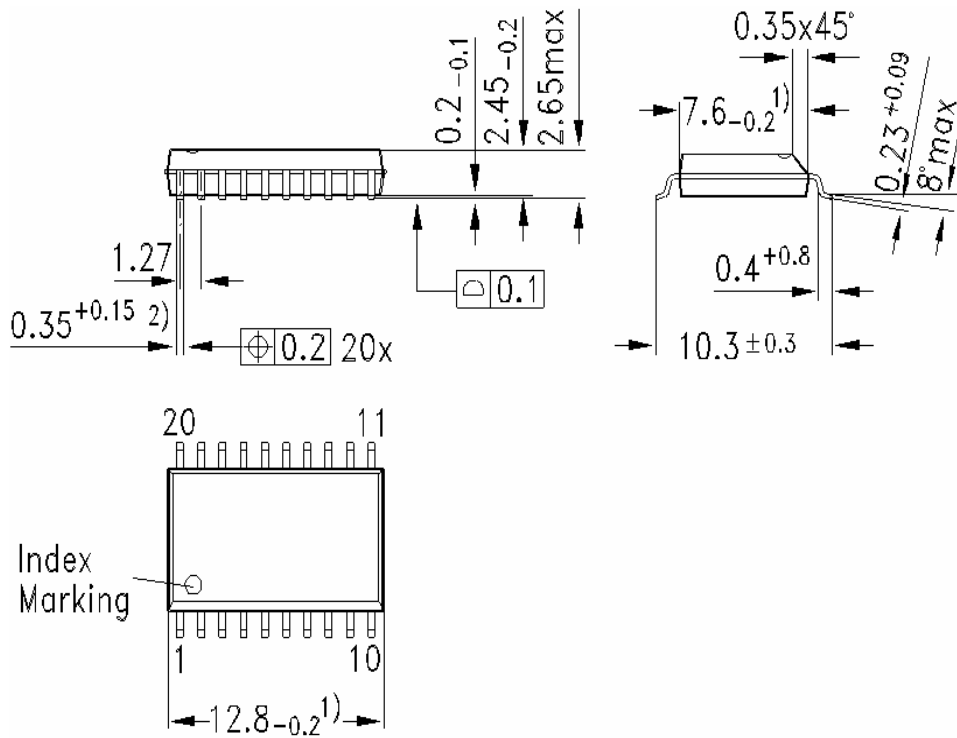

<sup>5</sup> For detailed information about packages please contact  
[http://www.infineon.com/cgi/ecrm.dll/ecrm/scripts/pack\\_cat.jsp?oid=-8781](http://www.infineon.com/cgi/ecrm.dll/ecrm/scripts/pack_cat.jsp?oid=-8781)

**Published by**  
**Infineon Technologies AG,**  
**Bereich Kommunikation**  
**St.-Martin-Strasse 53,**  
**D-81541 München**  
**© Infineon Technologies AG 1999**  
**All Rights Reserved.**

**Attention please!**

The information herein is given to describe certain components and shall not be considered as warranted characteristics.

Terms of delivery and rights to technical change reserved.

We hereby disclaim any and all warranties, including but not limited to warranties of non-infringement, regarding circuits, descriptions and charts stated herein.

Infineon Technologies is an approved CECC manufacturer.

**Information**

For further information on technology, delivery terms and conditions and prices please contact your nearest Infineon Technologies Office in Germany or our Infineon Technologies Representatives worldwide (see address list).

**Warnings**

Due to technical requirements components may contain dangerous substances. For information on the types in question please contact your nearest Infineon Technologies Office.

Infineon Technologies Components may only be used in life-support devices or systems with the express written approval of Infineon Technologies, if a failure of such components can reasonably be expected to cause the failure of that life-support device or system, or to affect the safety or effectiveness of that device or system. Life support devices or systems are intended to be implanted in the human body, or to support and/or maintain and sustain and/or protect human life. If they fail, it is reasonable to assume that the health of the user or other persons may be endangered.