

Amplified "Mini" SiSonic™ Microphone  
Specification - *Halogen Free*

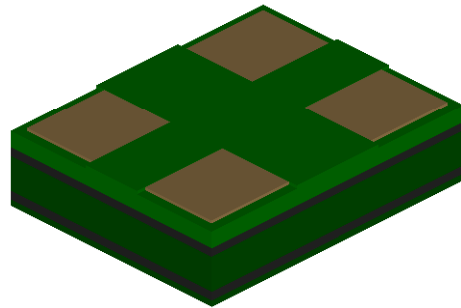
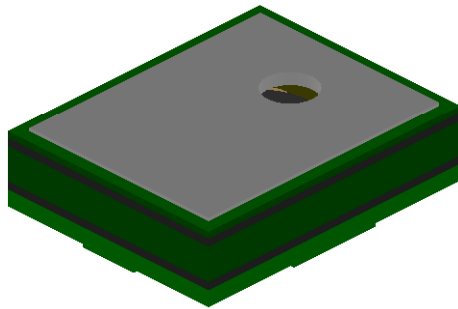

**Knowles Acoustics**  
1151 Maplewood Drive  
Itasca, IL 60143

## 1. DESCRIPTION AND APPLICATION

### 1.1 DESCRIPTION

Amplified "Mini" Surface Mount Silicon Microphone.

### 1.2 APPLICATION

Hand held telecommunication devices.

## 2. PART MARKING

Identification Number Convention

S	1	2	3
---	---	---	---

4	5	6	7
---	---	---	---

S: Manufacturing Location

"S" - Knowles Electronics Suzhou  
Suzhou, China

"No Alpha Character" - Knowles Electronics  
Itasca, IL USA

"E" - Engineering Samples

Digits 1-7: Job Identification Number

## 3. TEMPERATURE RANGE

3.1 Operating Temperature Range: -40°C to +100°C

3.2 Storage Temperature Range: -40°C to +100°C

#### 4. ACOUSTIC & ELECTRICAL SPECIFICATIONS

TEST CONDITIONS: +20 °C, 60-70% R.H.

	Symbol	Condition	Limits			Unit
			Min.	Nom.	Max.	
Directivity		Omni-directional	---	--	--	
Sensitivity	S	@ 1kHz (0dB-1V/Pa)	-25	-22	-19	dB
Output Impedance	Z <sub>OUT</sub>	@ 1kHz (0dB-1V/Pa)	---	--	300	Ω
Current Consumption	I <sub>DDS</sub>	Across 1.5 to 3.6 volts	100	--	350	μA
Signal to Noise Ratio	S/N	@ 1kHz (0dB-1V/Pa)	55	59	---	dB
Supply Voltage	V <sub>s</sub>		1.5	--	3.6	V
Typical Input Referred Noise	ENL	A-weighted	---	35	---	dBa SPL
Sensitivity Loss Across Voltage		Change in sensitivity over 3.6V to 1.5V	No Change Across Voltage Range			dB
Maximum Input Sound Level		At 100dB SPL, THD < 1% At 115dB SPL, THD ≤ 10%				

#### 5. FREQUENCY RESPONSE CURVE

**Typical Free Field Response**  
**NORMALIZED TO 1kHz, C1 = 2.2μF**

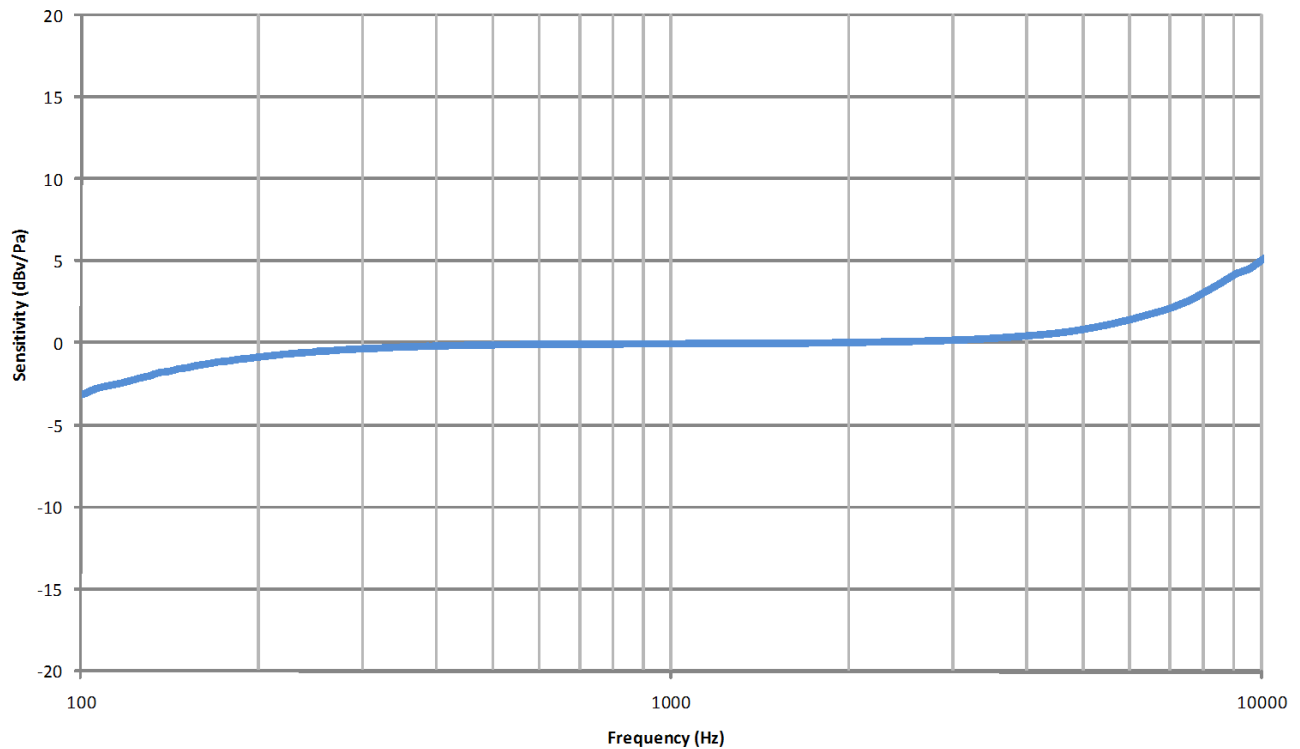

## 6. MECHANICAL SPECIFICATIONS

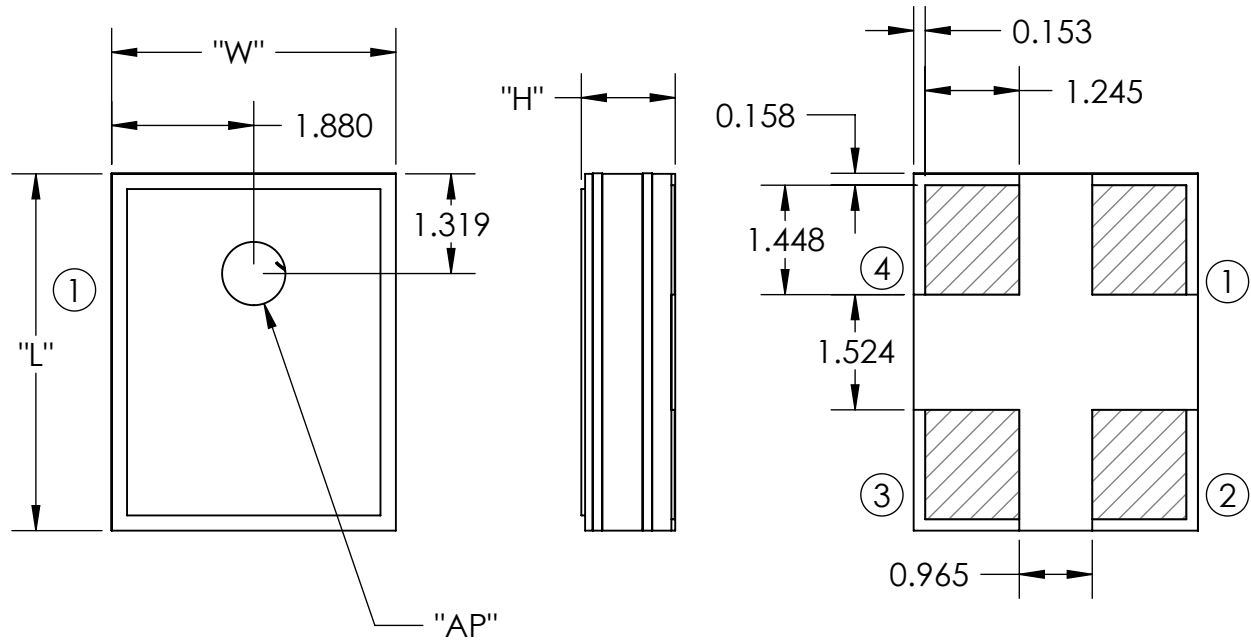

ITEM	DIMENSION	TOLERANCE	UNITS
LENGTH (L)	4.720	±0.100	mm
WIDTH (W)	3.760	±0.100	mm
HEIGHT (H)	1.250	±0.100	mm
ACOUSTIC PORT (AP)	∅0.838	±0.100	mm

PIN OUTPUT	
PIN #	FUNCTION
1	OUTPUT
2	GAIN
3	GROUND
4	POWER (Vdd)

**Note:**

**Dimensions are in millimeters unless otherwise specified.**

**Tolerance ±0.15mm unless otherwise specified.**

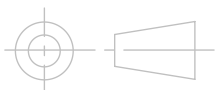

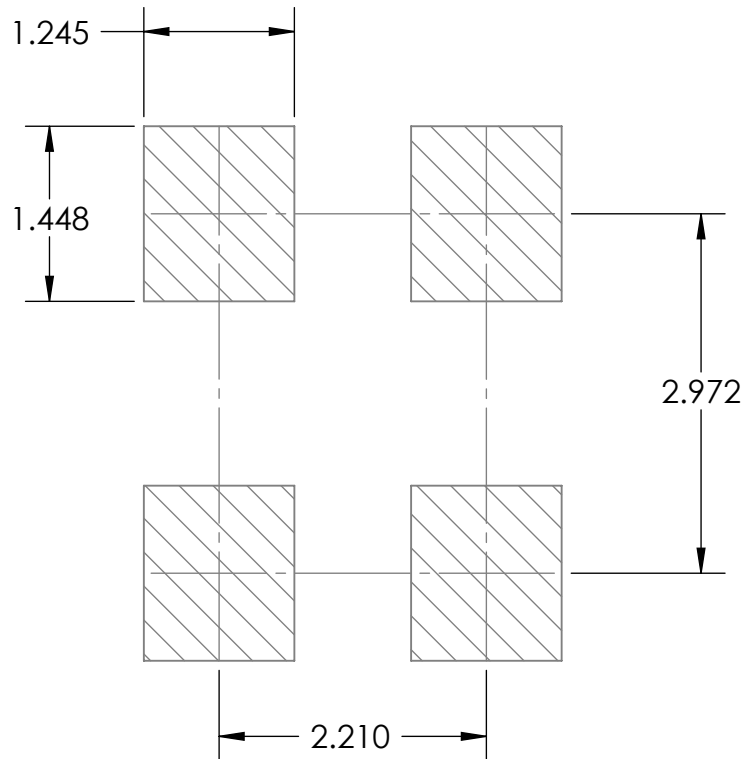
**7. RECOMMENDED CUSTOMER LAND PATTERN****8. RECOMMENDED SOLDER STENCIL PATTERN**

N/A

## 9. RECOMMENDED INTERFACE CIRCUIT

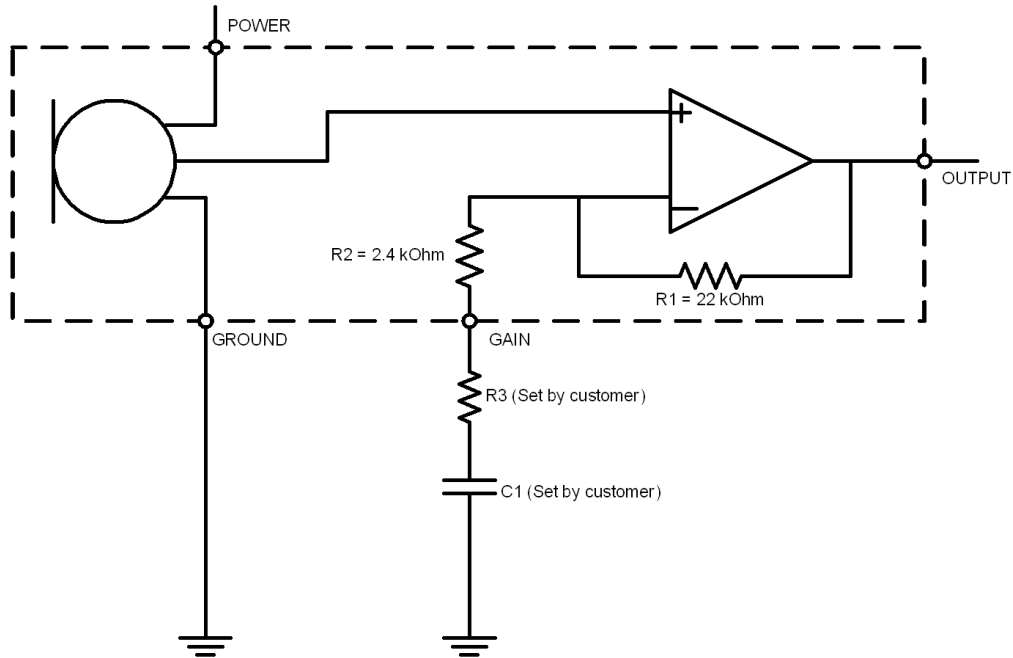

DESIRED GAIN	GAIN PIN TERMINATION METHOD
Unity Gain (0dB)	Tie Gain Pin directly to Output Pin
20dB Gain	Tie Gain Pin through C1 (0.47 $\mu$ F) to Ground
Adjustable Gain	Add Ground Pin and C1. Use formulas provided to calculate settings of contact Knowles for support.

### Setting Gain Formulas:

Gain on non-inverting Op-Amp is determined as:

$$\rightarrow G = 1 + \left\{ \frac{R1}{R2 + R3} \right\} \quad \text{Gain(dB)} - 20 * \log(G)$$

High-pass-filter Corner Frequency:

$$\rightarrow \text{C.F.} - 1 / \{ 2 * \pi * (R2 + R3) * C1 \}$$

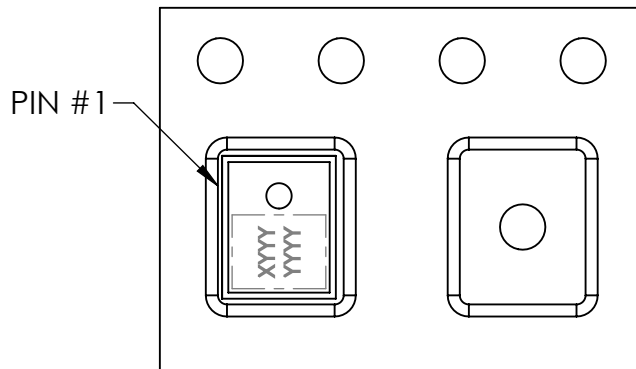
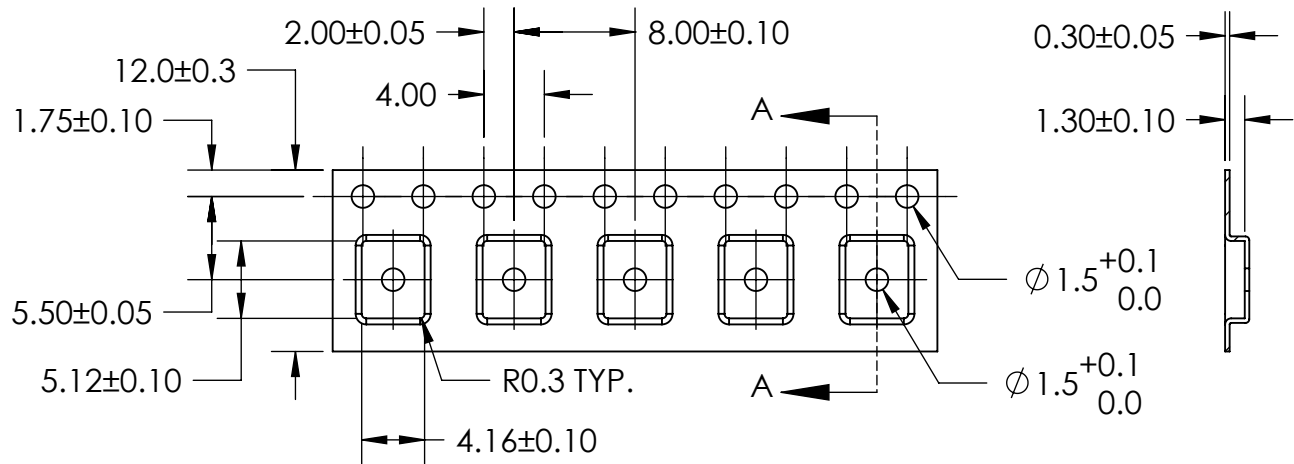
**10. PACKAGING DETAIL**

COMPONENT  
ORIENTATION

MODEL NUMBER	SUFFIX	REEL DIAMETER	QUANTITY PER REEL
SPM0404HD5H-SB	-2	7"	1,200
	-6	13"	4,800

TAPE & REEL	PER EIA-481
LABEL	LABEL APPLIED TO EXTERNAL PACKAGE & DIRECT TO REEL.

**Note:**

**Dimensions are in millimeters  
unless otherwise specified.**

## 11. SOLDER FLOW PROFILE

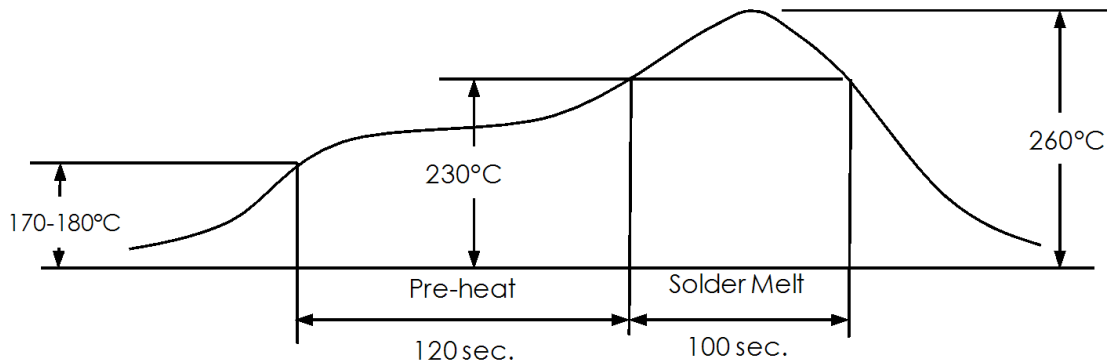

Stage	Temperature Profile	Time (maximim)
Pre-heat	170 ~ 180°C	120 sec.
Solder Melt	Above 230°C	100 sec.
Peak	260°C maximum	30 sec.

## 12. ADDITIONAL NOTES

- (A) Shelf life: Twelve (12) months when devices are to be stored in factory supplied, unopened ESD moisture sensitive bag under maximum environmental conditions of 30°C, 70% R.H. MSL (moisture sensitivity level) Class 2a.
- (B) Do not pull a vacuum over port hole of the microphone. Pulling a vacuum over the port hole can damage the device.
- (C) Do not board wash after the reflow process. Board washing and cleaning agents can damage the device. Do not expose to ultrasonic processing or cleaning.
- (D) Do not brush board after the reflow process. Brushing the board with/without solvents can damage the device.
- (E) Do not insert any object in port hole of device at any time as this can damage the device.
- (F) Number of reflow - Recommend no more than 3 cycles.



### 13. RELIABILITY SPECIFICATIONS

**Note:** After test conditions are performed, the sensitivity of the microphone shall not deviate more than 3dB from its initial value.

Test	Description
Thermal Shock	100 cycles of air-air thermal shock from -40°C to +125°C with 15 minute soaks. (ICE 68-2-4)
High Temperature Storage	+105°C environment for 1,000 hours. (ICE 68-2-2 Test Ba)
Low Temperature Storage	-40°C environment for 1,000 hours. (ICE 68-2-2 Test Aa)
High Temperature Bias	+105°C environment while under bias for 1,000 hours. (ICE 68-2-2 Test Ba)
Low Temperature Bias	-40°C environment while under bias for 1,000 hours. (ICE 68-2-2 Test Aa)
Temperature / Humidity Bias	+85°C/85% R.H. environment while under bias for 1,000 hours. (JESD22-A101A-B)
Vibration	4 cycles lasting 12 minutes from 20 TO 2,000 Hz in X, Y and Z direction with peak acceleration of 20g. (MIL 883E, Method 2007.2, A)
Electrostatic Discharge	3 discharges at +/-8kV direct contact to lid when unit is grounded (IEC 61000-4-2) and 3 discharges at +/-2kV direct contact to I/O pins. (MIL 883E, Method 3015.7)
Reflow	5 reflow cycles with peak temperature of +260°C.
Mechanical Shock	3 pulses of 10,000g in the X, Y and Z direction. (IEC 68-2-27, Test Ea)

